



Premier™ Series

Thermoplastic
Combination Unit

FEATURES

The **Premier™ Series** of combination units (emergency light battery unit with an Exit Sign) are designed with aesthetics, ease of installation and performance in mind.

- One-pack combination of battery unit and Exit Sign, a compact and contemporary design
- Durable injection-molded thermoplastic housing with push-to-snap design
- Available in single or double face configurations both with means for ceiling mounting
- Comes with the **Emergi-Lite® Premier™ EZ2** canopy and field-selectable snap chevrons for quick and easy installation
- Exit Sign module illuminated by long-life **ALINGAP** red LEDs
- Two LED lamps, shielded by a clear polycarbonate cover
- LED lamps with life expectancy 50,000+ hours
- Sealed, maintenance-free, Lead-Calcium or Nickel-Metal-Hydride batteries
- Dual voltage input: 120/347VAC or 120/277VAC.
- Optional vandal-resistant shield with tamper-proof screws
- Certified CSA C22.2 No.141
- Optional advance diagnostics circuitry available
- Advanced diagnostics capabilities (specific load requirements)
See warranty details at: www.tnb.ca/en/brands/emergi-lite



PREMIER™ FAMILY



Premier™ Exit Series

TYPICAL SPECIFICATIONS

Supply and install the **Emergi-Lite® Premier™ Series** combination emergency light battery unit and Exit Sign. The standard equipment shall operate with a dual voltage input of 120/347VAC. The unit shall be suitable for wall or ceiling mount.

The unit frame and face plates shall be made of injection-molded durable high-impact thermoplastic and come standard with snap in/out chevrons. No screws are necessary to hold the faceplate or backplate to the housing. The one-piece thermoplastic frame is molded in white (optional black). The faceplates shall feature a uniformly illuminated legend. The light source shall be light emitting diodes (LED) and shall provide illumination in normal and emergency operation and shall be mounted inside the combination housing. Red LED technology shall be **ALINGAP**. An LED-sensitive diffuser shall be mounted behind the legend to provide the 6" high by 3/4" stroke letters with even illumination.

The unit shall be equipped with two emergency heads with tool-less adjustable swivels (lamps of 12W or less) and long-life LED type lamps of ___ V and ___ W. Each lamp shall be protected by a snap-on, shock-absorbent, transparent polycarbonate cover.

The unit shall be equipped with a test switch and a green pilot light, located on the face plate above the EXIT legend. The battery charger shall be driven by a micro-controller. All electronic circuitry (charger, LED driver, LED's) shall be installed on a single printed circuit board PCB.

The unit equipped with self-testing / self-diagnostic features shall automatically self test for one minute every 30 days, 10 minutes in the 6th month and 30 minutes annually. When a fault is detected, the bi-color pilot light shall turn from green to red and shall flash, identifying the source of the failure: battery, charger circuitry, lamp load, LED strip. The Exit Sign module shall be CSA-C860 approved

The combo unit shall be **Emergi-Lite®** Model: _____ .

WIRE GUARDS

460.0078-E	Wall Mount
------------	------------

POWER CONSUMPTION

MODEL	AC SPECS		WATTAGE CAPACITY				
			30MIN	1H00	1H30	2H00	4H00
Exit Sign Module	120/347VAC	Less than 2W	-	-	-	-	-
L2		0.11/0.04 A	20	15	12	8	-
L5			50	30	24	16	8
L5A		0.22/0.08 A	50	30	24	16	8
H5A			50	36	24	18	9

Premier™ Series

Thermoplastic
Combination Unit



DIMENSIONS

Dimensions are approximate and subject to change.

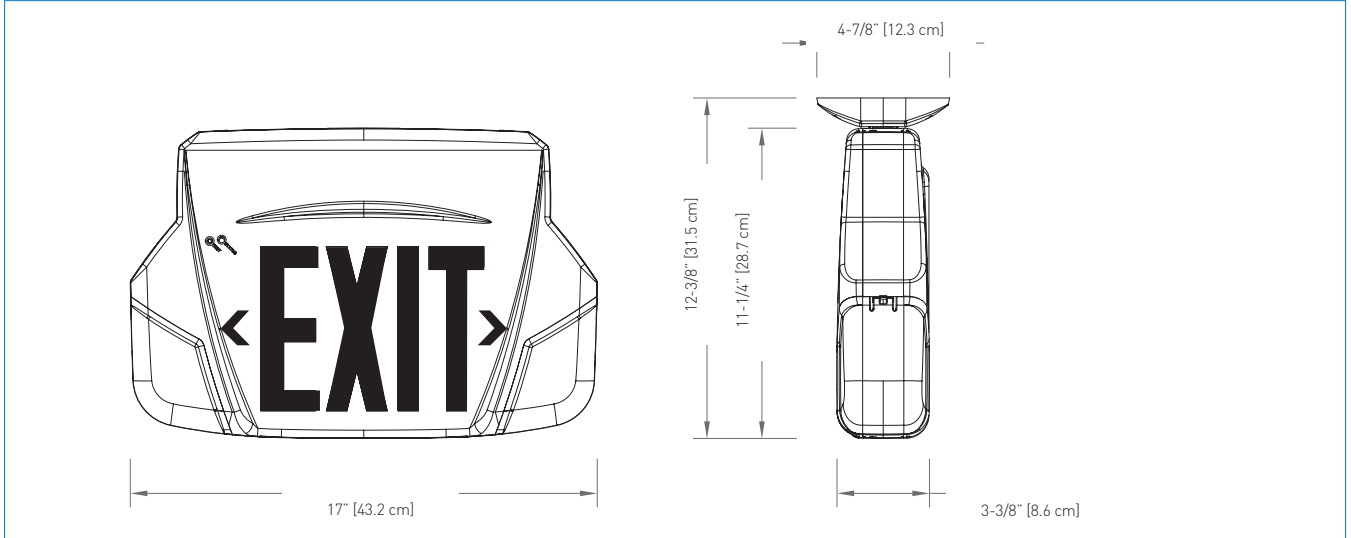

ORDERING INFORMATION

SERIES	COLOUR	VOLTAGE	POWERPACK	LEGEND	OPTIONS	# OF HEADS	HEAD STYLE/WATTAGE
<p>PRE1= single face ceiling or wall mount</p> <p>PRE2= double face ceiling mount</p> <p>PRE1N= single face wall mount (less canopy)</p> <p>PREU= universal, 2 faces backplate and canopy</p>	<p>B= black</p> <p>W= factory white</p>	<p>3= 120/347VAC</p> <p>2= 120/277VAC</p>	<p>-L2= 6V-20W Lead cal</p> <p>-L5= 6V-50W Lead cal</p> <p>-L5A= 12V-50W Lead cal</p> <p>-H5A= 12V-50W NiMH</p>	<p>Blank= red legend</p> <p>G= green legend</p>	<p>Blank= no options</p> <p>U= auto-diagnostics</p> <p>UD= auto-diagnostics, non-audible</p> <p>NEX= NEXUS® system interface¹</p> <p>NEXRF= wireless NEXUS® system interface¹</p> <p>BA= brushed aluminum exit stencil</p> <p>D3= time delay (15 minutes)</p> <p>-TP= tamper-proof screws²</p> <p>-VR= polycarbonate shield with tamper-proof screws²</p>	<p>/0= no heads</p> <p>/2= two heads</p>	<p>LA= MR16 LED, 6V-4W</p> <p>LB= MR16 LED, 6V-5W</p> <p>LG= MR16 LED, 12V-4W</p> <p>LI= MR16 LED, 12V-5W</p> <p>LJ= MR16 LED, 12V-6W</p>
					<p>¹ Not all options available with NEXUS® system. Please consult your sales representative</p> <p>² 091957-E= tamper-proof bit (sold separately)</p> <p>VR is not available with PREU</p>		

EXAMPLE: PRE1W3-L2/2LB