

 **EMERGI-LITE®**

**FULL RANGE OF  
EMERGENCY  
LIGHTING SOLUTIONS**



# TABLE OF CONTENTS

Company Profile	4-5
MR16 LED Emergency Lighting	6-7
Nexus® Management System	8-9

## EXIT SIGNS

Table of contents	13
Introduction	14-15
EDE Series	16-17
EX30 Series	18-19
EAE Series	20
EX3 Series	21
C8SR3 Series	22
EX3F Series	23
C8SR35 Series	24
C8ES35 & C8SE35 Series	25
C8E/S35R Series	26
PRE Series	27
Prestige™ LPEX100 Series	28
Prestige™ LPSR100 Series	29
LPEX300 Series	30
LPSR300 Series	31
C8ES300 & C8SE300 Series	32
EA Series	33
LPEX50 Series	34
C8SR50 Series	35
LPEX Series	36
LPEX54 Series	37
C8ES70 & C8SE70 Series	38
ES70B12 & SE70B12 Series	39
EAC Series	40-41
LPEX50-P Series	42
C8SR50-P Series	43
ES Series	44
EX10 Series	45
C8SR10 Series	46
C8ES10 & C8SE10 Series	47
ESC Series	48
EX10-P & LPEX10-P Series	49
SR Series	50-51
12ESL-EX Series	52
12ESL-SR Series	53
EP Series	54
Premier™ Exit Series	55
Premier™ Combo Series	56-57
C8SRPK Series	58
C8ESPK & C8SEPK Series	59
C8SRPK-P Series	60-61
Survive-All™ EN Series	62
Survive-All™ LPEX600 Series	63
Survive-All™ ENC Series	64
Survive-All™ LPEX600-N Series	65

EH Series	66
LPEXHZ Series	67
EHC Series	68-69
EXHZ Series	70-71
EX Series	72-73
LPEX-XP Series	74-75
C8SRXP Series	76-77
EXP Exit Series	78-79
EXP Sortie Series	80-81
ET Series	82
Special Wording	83
LED Retrofit Kits	84-86
Pendant Kit	87
Wire Guards	88-89
EZ2™ Canopy	90
Glossary	91

## BATTERY UNITS

Table of contents	95
Introduction	96-97
Lux-Ray™ Series	98-99
Retract-a-Lite™ Series	100
Mini Retract-a-Lite™ Series	101
Provider™ Series	102
Distinction™ Recessed Series	103
Distinction™ Series	104-105
DEL Series	106-107
ESLT Series	108-109
Wonderpack™ WP36 Series	110
Eclipse™ Series	111
JMLC Series	112-113
JMLA Series	114
JEM18P Series	115
Premier™ Series	116-117
ESL Series	118-119
Survive-All™ NXM Series	120-121
IPE Series	122
SIPE Series	123
ESLPK Series	124-125
HZM Series	126-127
ESLNX Series	128-129
48 & FPS Series	130
Glossary	131

## REMOTE FIXTURES

Table of contents	135
Introduction	136-137
Lux-Ray™ Series	138
EF40 & EF40-P Series	139
Retract-a-Lite™ Series	140

Mini Retract-a-Lite™ Series	141
Literay™ Series	142
EF9/EF9Q/EF9M Series	143
EF15 Series	144
EF18/EF18D/EF18T Series	145
Distinction™ Series	146
Distinction™ EFR Series	147
Survive-All™ EF39&EF39-P Series	148-149
EF25 Series	150
EF26/EF26DS/EF26D Series	151
EF11 Series	152
EF30 Series	153
EF41 Series	154
EFXPR	155
Lamp Charts	156-158
Glossary	159

## CENTRAL SYSTEMS

Table of contents	163
What is Emex	164-165
IPS Single Phase Series	166-167
IPS Three Phase Series	168-169
System Options	170
User Interface & Display Functions	171
Central System Request Data Form	172
Unity Series	174-175
CH Series	176-178

## OPTION & ACCESSORIES

Table of contents	183
LED Retrofit Kits	184-185
LED BULB Series	186
48 & FPS Series	187
EZ2™ Canopy	188
Pendant Kit	189
Wire Guards	190-191
Nexus® Management System	192-193

## TECHNICAL INFORMATION

Table of contents	197
Wire Size Guide	198
Battery Unit Capacity Chart	199
Electrical Code	200-201
Building Code	202-205
Fire & Generator Room Code	206
Limited Warranty	207
Product Index	208

# COMPANY PROFILE

## UNIQUE NORTH AMERICAN THOMAS & BETTS MANUFACTURING FACILITY

Vertically-integrated manufacturing and production capabilities in North America give Thomas & Betts complete control over lead time, service, and quality down to the smallest detail. We produce exactly what we need when we need it, without waiting for large production runs or overseas shipping. With everything under one roof, we can ensure that our stringent quality standards are met at every step in the process from design to production to order fulfillment.

## INNOVATIVE

The in-house research and development team of highly skilled professional electrical and mechanical engineers, designers, and technicians at Thomas & Betts includes specialists with over twenty-five years of experience in the emergency lighting industry. This multi-disciplinary group uses advanced technology in all specialties from mechanical design to operating system software, RF and power electronic design, lighting design, and LED drivers to continuously create innovative emergency lighting solutions. Comprehensive engineering services are provided to meet special requests from customers for unique applications. Quality and safety are designed into each product at conception, and customized testing equipment is created to ensure that each unit meets codes and conforms to internal quality control standards including ease of installation and reliability over time.

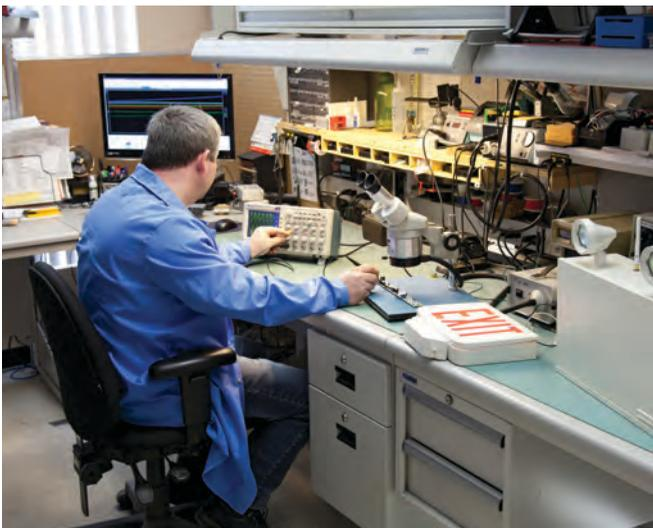

*Fuelled by the creativity, innovation and commitment of every employee, the Thomas & Betts facility is a centre of excellence in emergency lighting.*

## RELIABLE

Technologically advanced printed circuit board production lines at the Thomas & Betts manufacturing facility produce thousands of circuit boards daily. Skilled production personnel are trained according to IPC standards, and use board traceability and tracking software to ensure quality. Universal SMT (surface mount technology) boards and TH (through-hole) insertion boards are produced in house on multiple lines. Every station is ESD (electro-static discharge) protected to eliminate static hazards, and our ROHS-compliant wave soldering machine meets lead-free criteria. Automatic insertion equipment and automatic silicone coating application ensure high productivity and quality. Highly efficient electro-mechanical assembly lines are optimized for low volume, high mix production runs with thousands of final assemblies produced each day. Customizations such as specific punching, exact wording, and color matching can be completed quickly using our in-house machine shop and painting capabilities.

All orders undergo functional testing and quality inspection, with high-voltage, high-amperage power outage simulations available to test all central power systems for each customer's specific requirements. Specialized facilities include a dark room for color contrast measurement; temperature and humidity controlled environments; wall, ceiling and suspended ceiling installation simulations; and cycle testing automation.

## EFFICIENT

Large inventories are ready to ship from warehouses across the country for fast delivery. To reduce the carbon footprint and minimize the environmental impact of operations, a Sustainable Development policy is in effect at the Thomas & Betts manufacturing facilities. Through a series of initiatives, reductions in usage of water, water bottles, electricity and natural gas, packaging, and pallets have already been realized. Forward-looking initiatives include reductions in paper, further recycling of pallets, and implementation of an eco-delivery schedule.



*The Thomas & Betts manufacturing facility has been ISO 9001 compliant since 2001.*



*Frequent investments in new equipment improve lead time and enforce the high quality and reliability standards of Thomas & Betts. The new AOI (automated optical inspection) machine added to the printed circuit board operation in 2012 is one of the first of its kind in use in North America.*

# MR16 LED EMERGENCY LIGHTING

## MR16 LED ILLUMINATION

With the remarkable technology development in the last decade, the light-emitting diode (LED) is becoming the preferred solution in low- and medium-power lighting applications. The emergency lighting industry is no exception: today virtually every new product introduced to market includes "white" LEDs for emergency illumination.

Extremely efficient and long-lasting, LED lamps become the natural alternative to incandescent lamps due to three main advantages:

- = lamp efficacy: 50 - 70 lumen per watt compared to 15 - 30 lumen per watt of the best halogen lamp.
- = operational life: 30,000+ hours, equivalent to a lifetime warranty in emergency lighting.
- = lower lamp temperature (80 - 120°C) is a huge benefit for lighting in hazardous locations.

## 200-LUMEN 4W MR16 LED

Leading the technology trend, **Emergi-Lite®** offers a complete series of 4W MR16 LED lamps available for all the standard battery voltages: 6V, 12V, 24V and 120V. With up to 30,000 hours of operational life and a luminous flux of typically 200 lumens, they are available with most emergency heads designed to hold an MR16 lamp and meet the majority of illumination specifications. For example: one pair of LED emergency heads installed at a height of 7.5ft, illuminates a 6ft by 40ft path of egress.

Compared to halogen lamps (16-20W), these 4W MR16 LED lamps illuminate the same area of egress during an emergency situation by using 75% less power. This has a direct impact on the battery size, reducing the back-up capacity needs by 75%. Consequently, it also reduces the total cost of the application, with the use of smaller battery capacity units, the possibility of using fewer fixtures due to superior illumination, thus also reducing electrical wiring, and it reduces the environmental footprint.

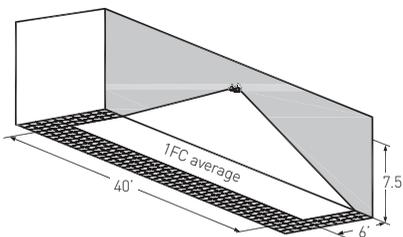

## MR16 LED LAMP BENEFITS

- CSA C22.2 No. 141 certified.
- Energy-efficient LED MR16 lamp provides equivalent lighting performance to a much higher watt halogen MR16 lamp.
- Reduces required battery capacity by 75%, providing necessary illumination with fewer remote heads and battery units for project cost savings.
- Small profile, compact white lighting is ideal for architectural applications.
- Vibration-resistant LED stands up to industrial environments.
- Ideal for indoor and outdoor use.

## 340-LUMEN 5W MR16 LED

Keeping pace with technology, in 2012 we introduced a 12V-5W MR16 LED lamp. With a typical luminous flux of 340 lumens, this lamp has the same lighting performance as a 20W high-output halogen MR16. A twin emergency head installed at a height of 7.5ft illuminates more than a 70ft path of egress.

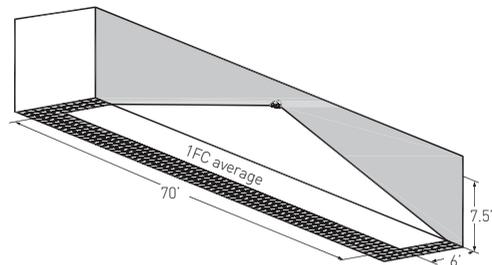

## 510-LUMEN 6W MR16 LED

New in Fall 2013, we introduce a 12V - 6W MR16 LED lamp, which offer typical luminous flux of 510 lumens. Like the lower wattage MR16 LED lamps, this new lamp is specially designed for emergency lighting. It offers the same lighting performance as the 35W or 20W Mr16 IR. A twin emergency head installed at a height of 7.5' illuminates approximately 100' path of egress.

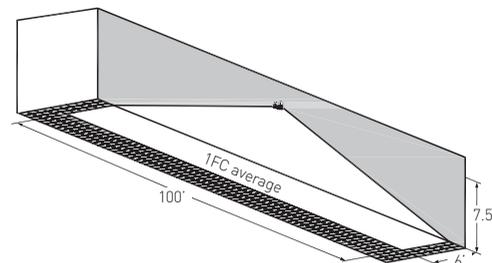

## CASE STUDY: FEWER MR16 LED UNITS REQUIRED

Emergency lighting units with MR16 LED lamps provide the same illumination at floor level using significantly fewer units.

- Reduced Installation Costs, due to reduced product and labour requirements.
- Reduced Energy Costs, keeping fewer batteries charged at full capacity to be ready to respond to an emergency situation at any time.

- Reduced Maintenance and Testing Costs, with fewer units to maintain and test in the Emergency Lighting System.
- Reduced Lamp Replacement Costs. LED lamps have a 30,000+ hour lamp life compared to only a few hundred hours typical with incandescent lamps.
- Reduced Environmental Impact, less product materials, less batteries, less transportation, less packaging, less labor, less waste.

## COMPARE

Where the building code requires an average of 1 foot-candle and a minimum of 0.1 foot-candle at floor level along the path of egress on a 150' x 9' x 9' corridor with an egress door at one end, a 150' x 6' path of egress, and a 7.5' unit mounting height.

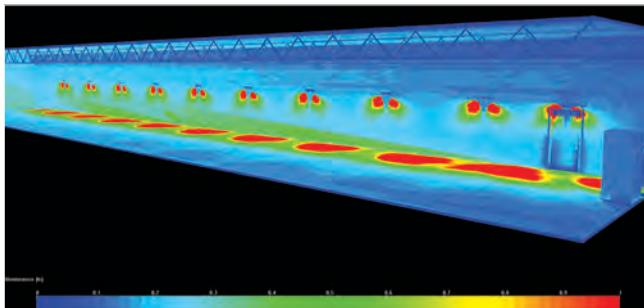

### STANDARD WEDGE-BASE 9W INCANDESCENT LAMP

Standard Emergency Lighting Units with 9W wedge-base incandescent lamps

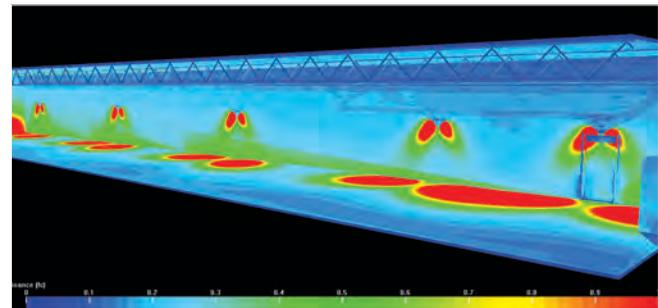

### 4W MR16 LED LAMPS

Same Standard Emergency Lighting Units with 4W MR16 LED Lamps

LAMP SUFFIX	VOLTAGE	WATTAGE	LUMENS	REPLACEMENT #
LA	6	4	130	580.0097-E
LG	12	4	170	580.0093-E
LL	24	4	200	580.0098-E

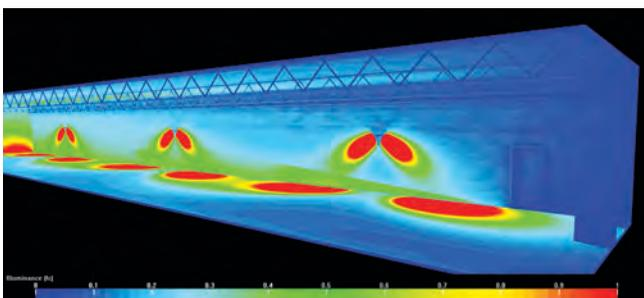

### 5W MR16 LED LAMPS

LAMP SUFFIX	VOLTAGE	WATTAGE	LUMENS	REPLACEMENT #
LI	12	5	340	580.0104-E

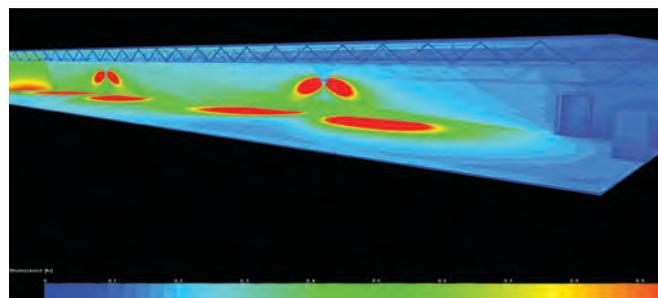

### NEW! 6W MR16 LED LAMPS

LAMP SUFFIX	VOLTAGE	WATTAGE	LUMENS	REPLACEMENT #
LJ	12	6	510	580.0106-E

# NEXUS® EMERGENCY LIGHTING MANAGEMENT SYSTEM

## ARE YOU PREPARED FOR A SAFETY INSPECTION?

Building & Life Safety Codes oblige building owners/managers to ensure the safe evacuation of a building in the event of an emergency. In the interest of public safety, building owners/managers must meet the outlined requirements for exit signs and emergency lighting equipment, including the following:

- Conduct a discharge test every month.
- Conduct functional tests annually.
- Keep a log book of maintenance information.

Complying with these requirements can be labour intensive and costly, especially in large buildings where testing every emergency light requires many man-hours.

Disrupting the power supply during lengthy inspections can also put public safety at risk.

## MANAGE TESTING WITH NEXUS® TO SAVE TIME AND COSTS

Nexus® is a real-time monitoring system that manages the status of your entire Emergency Lighting and Exit Sign system from a central control unit. Nexus® runs diagnostics, performs required monthly and annual functional tests, generates maintenance logs and runs compliance reports.

Available in wired or wireless (RF) versions, Nexus® installations often pay for themselves in less than two years. In addition to operational savings, Nexus® helps increase system reliability and performance and reduces the risk of failed inspections. One building or a group of properties under the same management can be monitored with Nexus®.



## MAXIMIZE SYSTEM AVAILABILITY

By allowing maintenance personnel to easily maintain and monitor the emergency lighting system without having to manually check each unit, Nexus® reduces the hours required to disrupt the power supply for inspections. With Nexus®, monthly tests and reports on the status of all emergency lights and exit signs can be done individually, in groups, or together.

Advantages of the Nexus® system include saving labor; maximizing system availability by testing units in groups and stages rather than setting all units in recovery mode; and the convenience of self-monitoring. Nexus® indicates the location of a faulty unit and reports it instantly without requiring a manual search.

## UPDATE STATUS INSTANTLY

Nexus® passes messages both to and from the emergency units to instruct the units to perform all mandatory testing by communicating between the emergency units and a centrally located controller.

Nexus® is a proven system supported by a 5-year warranty, and can contribute to LEED certification and support green building initiatives.



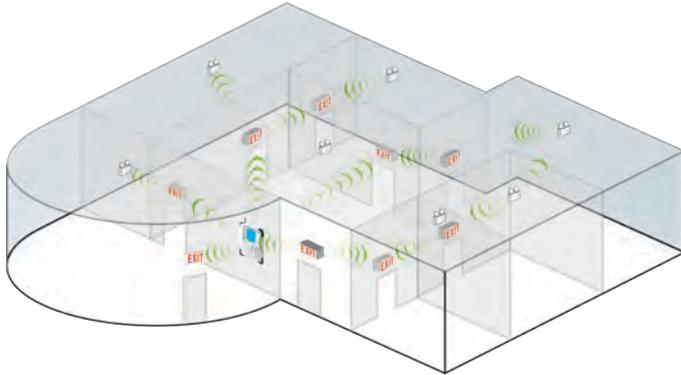

### SMALL SYSTEM EXAMPLE

In a system of fewer than 100 units it is most likely that the only hardware required, other than the emergency units themselves, is a controller. All communication would occur wirelessly and installation would not vary greatly from a non-monitored system. Once the units are in place, the system will establish the mesh network. The building itself could be quite large as each unit only needs to be able to communicate with its close neighbours and does not need to communicate directly with the controller.

### LARGE SYSTEM EXAMPLE

The Nexus® RF system has been designed to be extremely flexible and provides for a range of system options. Each large site will need to be assessed for the best system solution with the assistance of Thomas & Betts technical staff.

The basic Nexus® RF system is designed to run on an Ethernet network which is present in most modern buildings; however, through a range of interface cards the backbone of the network could be WLAN.

As with the small system example, site performance will be optimized through the careful selection and placement of Area Controller Routers and the Area Controller to form efficient clusters. Building layout and materials will also play some role in determining the best solution to deliver a highly effective means of testing and maintenance requirements.

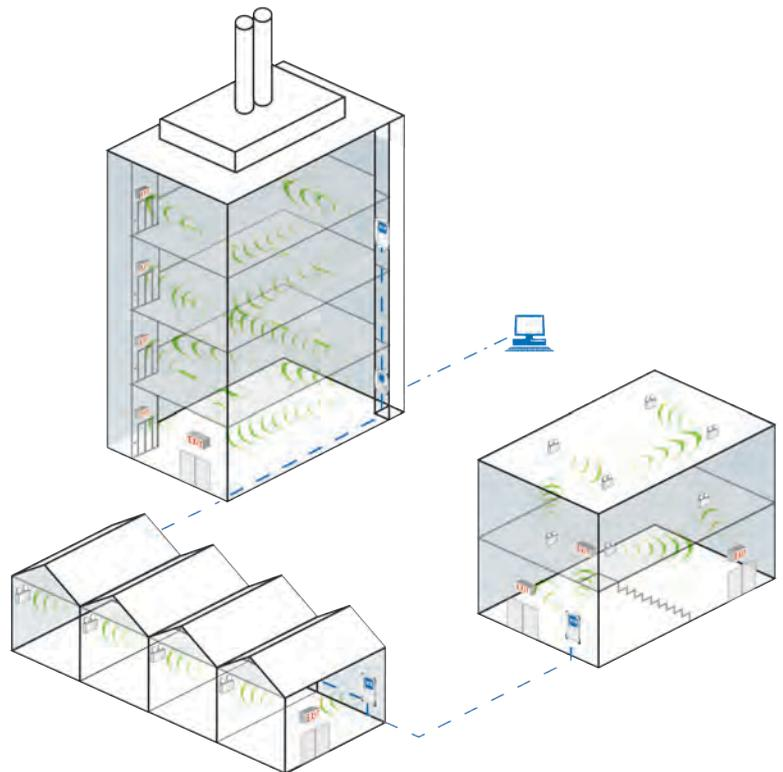

EX3F  
EX35

C8ES35  
LPEX-50

LPEX300

PREMIER

LPEX-XP  
EXP

LPEX54



# EXIT SIGNS

# TABLE OF CONTENTS

							
<b>INTRODUCTION</b>	<b>EDE SERIES</b>	<b>EX30 SERIES</b>	<b>EAE SERIES</b>	<b>EX3 SERIES</b>	<b>C8SR3 SERIES</b>	<b>EX3F SERIES</b>	<b>C8SR35 SERIES</b>
P.14-15	P.16-17	P.18-19	P.20	P.21	P.22	P.23	P.24
							
<b>C8ES35/SE35 SERIES</b>	<b>C8E/S35R SERIES</b>	<b>PRE SERIES</b>	<b>LPEX100 SERIES</b>	<b>LPSR100 SERIES</b>	<b>LPEX300 SERIES</b>	<b>LPSR300 SERIES</b>	<b>C8ES300 SERIES</b>
P.25	P.26	P.27	P.28	P.29	P.30	P.31	P.32
							
<b>EA SERIES</b>	<b>LPEX50 SERIES</b>	<b>C8SR50 SERIES</b>	<b>LPEX SERIES</b>	<b>LPEX54 SERIES</b>	<b>C8ES70/SE70 SERIES</b>	<b>ES70B12/SE SERIES</b>	<b>EAC SERIES</b>
P.33	P.34	P.35	P.36	P.37	P.38	P.39	P.40-41
							
<b>LPEX50-P SERIES</b>	<b>C8SR50-P SERIES</b>	<b>ES SERIES</b>	<b>EX10 SERIES</b>	<b>C8SR10 SERIES</b>	<b>C8ES10/SE10 SERIES</b>	<b>ESC SERIES</b>	<b>EX10-P &amp; LPEX10-P SERIES</b>
P.42	P.43	P.44	P.45	P.46	P.47	P.48	P.49
							
<b>SR SERIES</b>	<b>12ESL-EX SERIES</b>	<b>12ESL-SR SERIES</b>	<b>EP SERIES</b>	<b>PREMIER EXIT SERIES</b>	<b>PREMIER COMBO SERIES</b>	<b>C8SRPK SERIES</b>	<b>C8ESPK/SEPK SERIES</b>
P.50-51	P.52	P.53	P.54	P.55	P.56-57	P.58	P.59
							
<b>C8SRPK-P SERIES</b>	<b>EN SERIES</b>	<b>LPEX600 SERIES</b>	<b>ENC SERIES</b>	<b>LPEX600-N SERIES</b>	<b>EH SERIES</b>	<b>LPEXHZ SERIES</b>	<b>EHC SERIES</b>
P.60-61	P.62	P.63	P.64	P.65	P.66	P.67	P.68-69
							
<b>EXHZ SERIES</b>	<b>EX SERIES</b>	<b>LPEX-XP SERIES</b>	<b>C8SRXP SERIES</b>	<b>EXP SERIES</b>	<b>EXP SERIES</b>	<b>ET SERIES</b>	<b>SPECIAL WORDING</b>
P.70-71	P.72-73	P.74-75	P.76-77	P.78-79	P.80-81	P.82	P.83
							
<b>RETROFIT KITS</b>	<b>PENDANT KIT</b>	<b>WIRE GUARDS</b>	<b>EZ2 CANOPY</b>	<b>GLOSSARY</b>			
P.84-86	P.87	P.88-89	P.90	P.91			

# EXIT SIGNS OVERVIEW

Electrical Exit Signs (connected to a source of power) differ from battery units in that they shall be illuminated at all times during normal AC operation, and not only upon loss of AC power. This has a direct impact on the admissible energy consumption referenced in government regulations (National Resources Canada NRCAN, CSA C-860), which is a maximum of 5W per legend single or double face. A legend is defined as a single word, either "SORTIE" or "EXIT". There are also bilingual Exit Signs with: "SORTIE EXIT" or "EXIT SORTIE", quite common in applications such as airports or federal buildings. A bilingual Exit Sign is acceptable up to a maximum of 10W. The legend must also meet visibility standards including: lettering dimensions (minimum 150mm height, etc.), average brightness, uniformity, and lettering/background contrast ratio. The most popular light source is based upon solid state LED technology, which is capable of meeting both lumen output and energy efficiency requirements.

## BACK-LIT AND EDGE-LIT EXIT SIGNS

Two different methods are used to illuminate the legend. The most common is found in back-lit signs, which use a light source located behind the legend, illuminated through a red diffuser panel. The other method uses a clear, white or mirrored plastic (acrylic) face panel on which the legend is etched or silkscreened. The light source is installed in the top portion of the panel. Light is transmitted from the top edge of the panel, which is where the "Edge-Lit" Exit Sign gets its name from. In general, back-lit Exit Signs are more economical and provide more uniform illumination of the legend. On the other hand, acrylic Edge-Lit Exit Signs are considered more high-end, elegant fixtures.

## BATTERY, REMOTE, AC AND OTHER POWER SOURCES

Three types of fixtures are available for emergency lighting applications. The first type is the Self-Powered Exit Sign, with a rechargeable battery for emergency mode operation. Next is the Remote Exit Sign, or AC/DC Exit Sign: in addition to a normal AC power supply, it includes a DC input (6VDC, 12VDC, etc.) for remote power supplied by from a separate battery backup. Installation of such Exit Signs requires DC wiring between both fixtures. Finally, the AC-only Exit Signs are for applications where emergency power is supplied from an AC Central System. A variation on Exit Sign design uses photo-luminescent materials for the legend (letters and/or background). **According to the National Building Code, photo-luminescent Exit Signs must be continuously illuminated by a dedicated light source connected to an emergency power supply.**

In addition to electrical Exit Signs, there are power free, self-luminous signs, incorporate radioactive materials such as tritium gas as a light source. Their brightness level is very low, that is 2-3% of the minimum level required for an electrical sign. However, they are safer and easier to install in hazardous/explosion-proof environments such as coal mines, natural gas installations, etc. As these signs are not electrical signs, they are not subject to CSA standards such as C860-07.

## COMBINATION UNITS

A well established fixture type, the combination unit or "combo", includes both a small battery-powered Emergency Lighting unit and an AC/DC Exit Sign. An economical and easy to install alternative (installs to a single electrical box), the combo offers both an Exit Sign indicating the direction of egress as well as emergency lighting on the path of egress.

## EXPLOSION-PROOF ENVIRONMENT EXIT SIGNS

Does CSA C860 standard apply to all Exit Signs, and in all applications? Actually, there are no exceptions. Compliance is required in all cases, even though the solution may be hard to find. For example, equipment for use in hazardous locations, such as areas classified under Class I, Division 1 (or Class I, Zones 0 and 1), defined as locations where flammable gases, vapors or liquids are present frequently or under normal operating conditions.

Required luminaires are designed specifically to meet CSA standards for explosion-proof equipment. The heavy-duty luminaires are rated for lamp wattages ranging from 50-250W. Constructed of die-cast aluminum, the units feature a resistant prismatic glass globe providing hemispherical light distribution. Until now, because of these characteristics, traditional Exit Signs were using 15-25W incandescent lamps in order to provide sufficient illumination of the legend. Conversely, an LED Exit Sign is typically rectangular and relatively thin (4-8cm) with an axial light source consisting of a line of LEDs to provide indirect illumination of the legend through multiple reflections. So, how is it possible to develop an LED Exit Sign that meets NRCAN/CSA-C860 using a bulky heavy-duty luminaire dedicated to hazardous locations Class I, Division 1?

The Thomas & Betts R&D group has found a solution and developed a special LED lamp series that is easy to install in the lamp base of explosion-proof type luminaires. This special LED lamp consumes less than 5W in either AC or DC current of high performance **ALINGAP** LEDs configured in a unique pattern. Horizontal distribution is 360 degrees radially and vertical distribution is directly focused on the sign legend.

This innovative design meets the visibility criteria on standard size legends (EXIT 28cm x 15cm, SORTIE 42cm x 15cm), while limiting power consumption to between 3 to 4.7W per Exit Sign.

LED lamps are dedicated to various voltage ratings: 6V, 12V, 24V or 120V and operate on DC and AC, supplying power to the Exit Sign from emergency lighting unit equipment or central AC or DC systems. Lamps are listed/certified CSA C-US to CSA T.I.L. B-69 and UL1993 standards for LED technology based lamps or lamps with integral ballast. This further reinforces the assurance of performance and safety of the Exit Signs using these lamps. The new Exit Sign series from Thomas & Betts includes fixtures designed for installation in all hazardous location classifications: Class I Divisions 1 and 2, Groups A, B, C and D; Class II Divisions 1 and 2, Groups E, F, and G; Class III Divisions 1 and 2. Specifiers specialized in industrial lighting are now assured that they can specify certified hazardous location equipment also approved and compliant to NRCan/CSA C-860 standards. Sustained R&D efforts in the optoelectronics industry have led to a new development in LED manufacturing: "ALINGAP" technology. Based on the compound of four elements: Aluminum, Indium, Gallium and Phosphorous, it offers higher light efficacy, **with the lumen/watt ratio 300% to 500 % higher than the traditional GaAs LED**. In addition, the new technology also significantly improves the maintained light output of the LED by utilizing materials that operate at lower temperatures than the previous generation of LEDs.

Due to increased market awareness on the subject, LED manufacturers have started to publish test results and statistical data related to the light degradation phenomenon. Among other data publicly available on the Internet, an article from a leading semiconductor manufacturer (\*Agilent Technologies, Application Brief I-018) describes the results of a High-Temperature Operating Life (HTOL) test carried on **ALINGAP** LEDs during a 16,000-hour time frame. Based on the test results, the authors estimate that **ALINGAP** LEDs exposed to 100,000 hours (11.4 years) of continuous use at an ambient temperature of +55°C would exhibit an overall light output degradation of about 27%, which translates to an annual loss rate 10 times lower than the average light loss of traditional GaAs LEDs.

The outstanding results of **ALINGAP** technology have enabled the engineers at Thomas & Betts to design a new generation of Exit Signs with sustained lighting performance and reduced power consumption. The **ALINGAP** LED signs have an initial **level of legend illumination that is 35 to 50 % higher** than the severe requirements of CSA/C860 and UL924 standards.

This increase will compensate for the expected 27% light degradation over time, allowing the equipment to still meet the visibility criteria **more than ten years after field installation**.

Unlike other emergency lighting manufacturers, who only guarantee equipment against functional defects, **Emergi-Lite® ALINGAP** Exit Signs are designed for 10 years+ of CSA/UL photometric compliance.

Make sure your customer writes "**ALINGAP LED**" in his specification for Exit Signs. This represents the best assurance for Energy Efficiency, Long Life and Maintained Performance.



# EDE Series

Die-Cast Aluminum Pictogram  
Edge-Lit Sign

Project/Location:	_____
Contractor:	_____
Date:	_____
Prepared by:	_____

## FEATURES

- Self-Powered models provide minimum 120 minutes of emergency lighting
- Die-Cast aluminum construction
- Modular design offers great choice of architectural profiles
- Universal Die-Cast back-box for surface or semi-recessed mounting on ceilings or walls
- LED strip module can be rotated in the unit for either wall or ceiling mount
- Flat Die-Cast trim plate and galvanized steel back-box for recessed ceiling mount
- Clear acrylic panel with pictogram legend
- Comes standard with double-face panels for use in single-face and double-face applications
- White LED light source
- Universal AC input: two-wire 120 to 347VAC; universal DC input: two-wire 6 to 24VDC
- Energy efficient – consumes less than 2.5W in AC and DC-remote modes
- Meets or exceeds CSA 22.2 No.141-10



nexus®

## TYPICAL SPECIFICATIONS

Supply and install the **Emergi-Lite® EDE Series** of Die-Cast pictogram Edge-Lit signs.

When specified for surface mount, the unit shall come standard with a trim plate, trim ring, back box and canopy made of Die-Cast aluminum with \_\_\_\_\_ finish. The trim plate shall have a \_\_\_\_\_ profile and allow for wall- or ceiling-mount installation. The trim ring shall allow for semi-recessed installation in walls or ceilings with cavity. The canopy shall allow for wall, end, or ceiling mount.

When specified for recessed ceiling-mount, the unit shall come standard with a flat trim plate of Die-Cast aluminum with \_\_\_\_\_ finish, a back box of galvanized steel, and a hardware kit for back box installation between ceiling joists. The back box shall be provided with conduit knock-outs at the top, back and end.

All Edge-Lit units shall have the trim plate snap and lock in the housing with torsion spring retainers, thereby eliminating any visible screws or hardware. The legend shall be printed on a clear acrylic panel. The panel shall come standard with double-face legend, for single-face and double-face applications. The light source shall be long-life white light-emitting diodes (LED) and shall provide even illumination in normal and emergency operation. The Edge-Lit sign shall operate with universal 2-wire AC input voltage of 120 to 347VAC at less than 2.5W and universal 2-wire DC input voltage from 6 to 24VDC at less than 2.5W. The Edge-Lit sign in a Self-Powered configuration shall use a sealed Nickel-Cadmium battery of 2.4V nominal voltage and shall stay illuminated during emergency operation for at least two hours upon AC failure.

When specified, the Self-Powered unit shall include non-audible auto-test functions, managed by a micro-controller: it shall execute automatic tests for 5 minutes every 30 days, 30 minutes every 60 days and two hours annually. When a fault is detected a red flashing LED shall identify the failure type: battery, charger circuitry, or LED lamps. The Edge-Lit sign shall be listed CSA 22.2 No.141-10.

The equipment shall be **Emergi-Lite®** Model: \_\_\_\_\_.

## POWER CONSUMPTION

MODEL	AC SPECS		DC SPECS	
AC-only	120 to 347VAC	Less than 2.5W	-	-
AC/DC standard	120 to 347VAC	Less than 2.5W	6 to 24VDC	Less than 2.5W
Self-Powered	120 to 347VAC	Less than 3.5W	Nickel-Cadmium battery	Minimum 2 hours
Self-Powered diagnostic	120/347VAC	Less than 3.5W	Nickel-Cadmium battery	Minimum 2 hours

Project/Location:

Contractor:

Date:

Prepared by:

# EDE Series

Die-Cast Aluminum Pictogram  
Edge-Lit Sign



## DIMENSIONS

Dimensions are approximate and subject to change.

### ANGULAR TRIM

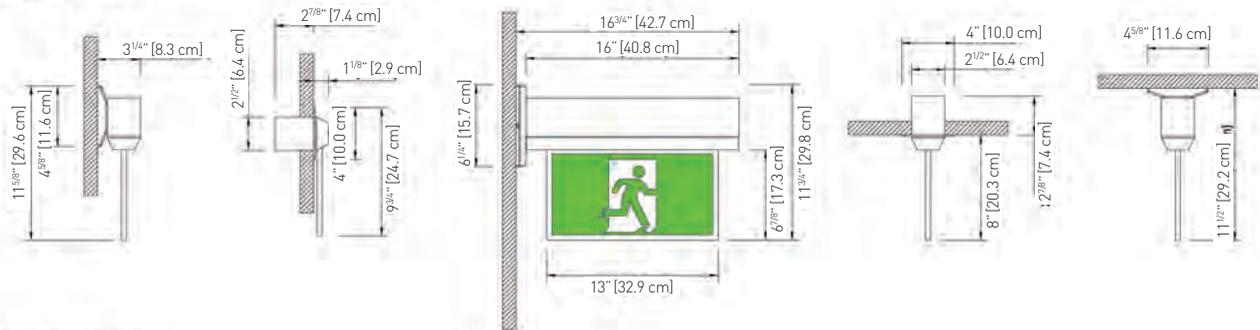

### CIRCULAR TRIM

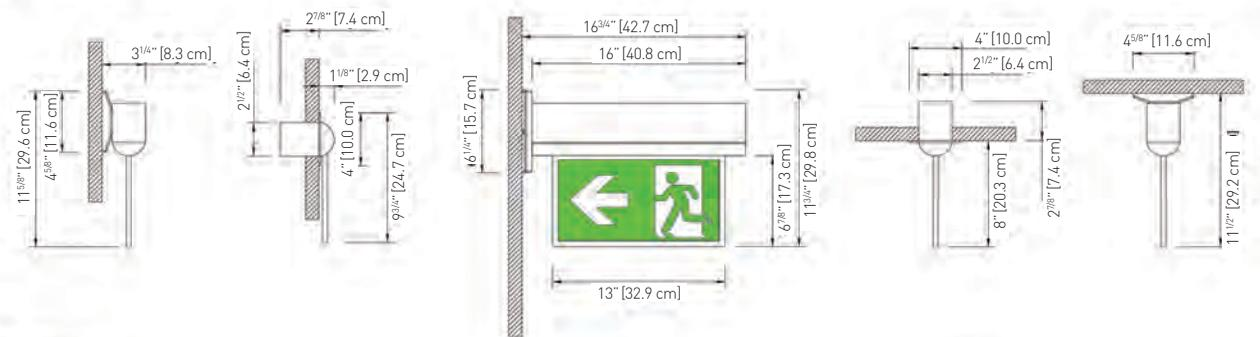

### FLAT TRIM

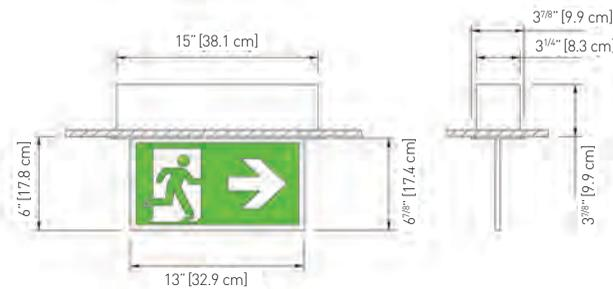

## ORDERING INFORMATION

SERIES	FACES/ARROW	COLOUR	TRIM	VOLTAGE
EDE= die-cast edge-lit pictogram exit sign	1= one face, no arrows L= arrow left, single face R= arrow right, single face 2= two face, no arrows A= universal two, arrow left or right	A= brushed aluminum B= black C= chrome P= polished brass W= factory white Z= bronze	A= angular C= circular F= flat (fully recessed)	AC= AC only, 120 to 347VAC U= 120 to 347VAC, 6 to 24VDC U48= 120 to 347VAC, 48VDC UI= Self-Powered, 120 to 347VAC ID= Self-Powered (non-audible), 120/347VAC ID2= Self-Powered (non-audible), 120/277VAC NEX= Nexus® system interface** NEXRF= wireless Nexus® system interface**

\*\*Consult your sales representative for options available with the Nexus® system

EXAMPLE: EDE2ACU

Unlike EXIT signs, the pictogram sign is not available in double arrow configurations.



# EX30 Series

Die-Cast Edge-Lit  
Exit Sign

Project/Location:
Contractor:
Date:
Prepared by:

## DESIGN UPGRADE - INTRODUCING NEW FEATURES:

1. Easier installation: component-free back-box housing and canopy can be installed in advance, like a regular junction box.
2. 20 – 30% less power consumption: max. 1.4W (AC-only models) and max. 2.5W (self-powered)
3. Bi-color LED pilot light allows visual diagnostic without need to open the unit (self-test and diagnostic option)
4. Listed by CSA
5. Also available with white LEDs for custom-design legends: pictograms, special wording, etc. (ask our sales representatives)

## FEATURES

- Die-Cast aluminum construction
- Modular design for universal mounting
- Trim plate choices: pyramid or round for universal mounting and flat (recessed ceiling)
- Component-free back-box ready to pre-install
- LED strip module can be rotated in the unit for either wall or ceiling mount
- U-shaped clear acrylic panel with laser-etched contour for legend letters
- Long-life LED light source; red LEDs of **ALINGAP** technology
- Two-wire universal AC input: 120 to 347VAC 50/60Hz
- Sealed, maintenance-free Nickel-Cadmium battery
- Meets or exceeds CSA 22.2 No.141-10



## TYPICAL SPECIFICATIONS

Supply and install the **Emergi-Lite® EX30 Series** of Die-Cast Edge-Lit Exit Signs.

The unit specified for universal mounting shall come standard with a trim plate, trim ring, back box and canopy all made of die-cast aluminum with \_\_\_\_\_ finish. The trim plate shall have a \_\_\_\_\_ profile and allow for wall- or ceiling-mount installation. The trim ring shall allow for recessed installation in walls or ceilings with cavity. The canopy shall allow for wall, end, or ceiling mount. The back box shall be provided with conduit knock-outs at the top, back and end.

The unit specified for recessed ceiling shall come standard with a flat trim plate of Die-Cast aluminum with \_\_\_\_\_ finish, and a back box of 20-gauge galvanized steel. The back box shall be provided with conduit knock-outs at the top, back and end.

All models shall be provided with a hardware kit including two 27" adjustable bar hangers for back box recessed installation.

The unit shall have the trim plate snap and lock in the housing with torsion spring retainers, thereby eliminating any visible screws or hardware. The legend shall be printed on a clear acrylic panel.

The panel shall have a U-shape and the legend shall have precision etched 6" high and 3/4" stroke red letters with laser-edged contour and with a white, clear or mirror background. The light source shall be long-life light-emitting diodes (LED) and shall provide even illumination in normal and emergency operation. Red LED technology shall be **ALINGAP**. The unit shall operate with two-wire universal AC input voltage from 120 to 347VAC and two-wire universal DC input from 6 to 24VDC, each input at less than 1.4W.

The Edge-Lit sign in a Self-Powered configuration shall use a sealed Nickel-Cadmium battery and shall stay illuminated during emergency operation for at least 90 minutes upon AC failure.

The Self-Powered unit with self-test and silent diagnostic functions shall be managed by a micro-controller: it shall execute automatic tests for one minute every 30 days, 30 minutes every 60 days and 90 minutes annually. A diagnostic circuit shall continuously monitor the performance of the battery, charger module and LED lamps. When a fault is detected the pilot light shall change colour from green to red and flash with a specific code. The red light is steady-on in case of battery disconnect; it will flash with one blink for battery failure, two blinks for charger failure and four blinks for LED lamp failure. A label with the diagnostic legend shall be visible next to the pilot light.

The Edge-Lit sign shall be certified CSA C22.2 No.141 and CSA-C860.

The Exit Sign shall be **Emergi-Lite®** Model: \_\_\_\_\_.

## POWER CONSUMPTION

MODEL	AC SPECS		DC SPECS	
AC-only	120 to 347VAC	Less than 1.4W	-	
AC/DC - remote	120 to 347VAC	Less than 1.4W	6 to 24VDC	Less than 1.4W
Self-Powered	120 to 347VAC	Less than 2.3W	Nickel-Cadmium battery	Minimum 90 minutes
Self-Powered diagnostic	120/347VAC	Less than 2.3W	Nickel-Cadmium battery	Minimum 90 minutes

Project/Location:

Contractor:

Date:

Prepared by:

# EX30 Series

Die-Cast Edge-Lit  
Exit Sign



## DIMENSIONS

Dimensions are approximate and subject to change.

### DIE-CAST EDGE-LIT

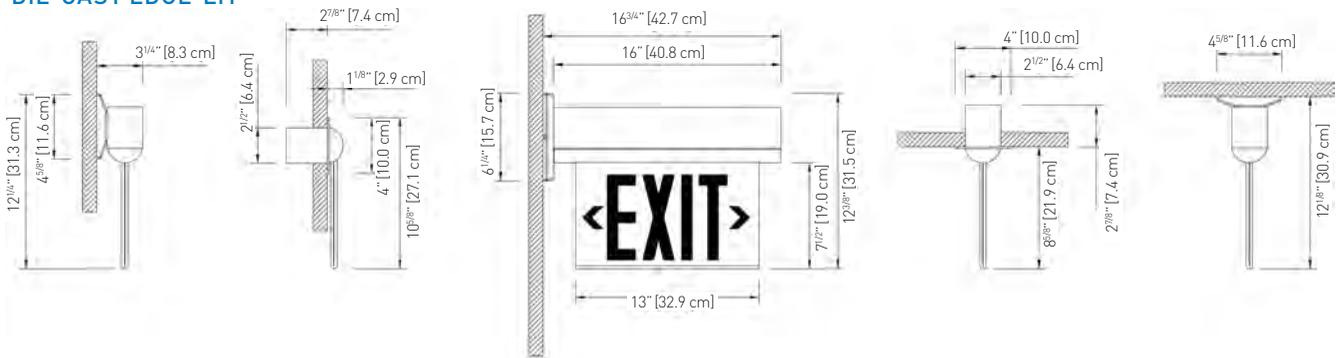

### DIE-CAST RECESSED EDGE-LIT

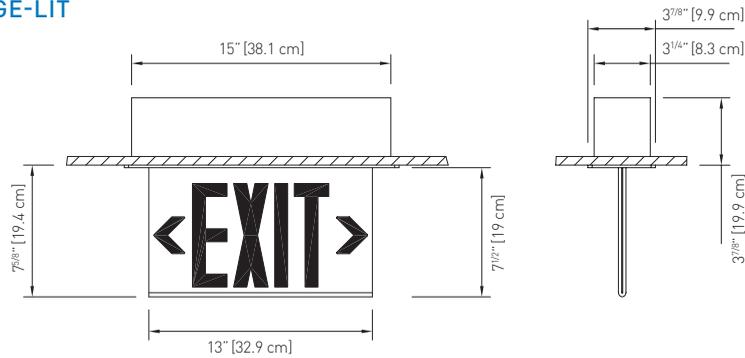

## ORDERING INFORMATION

SERIES	FACES	HOUSING COLOUR	FUNCTION	LEGEND COLOUR	BACKGROUND COLOUR	CHEVRONS	TRIM OPTION
EX3	1= single face 2= double face	B= black BA= brushed aluminum BR= bronze CH= chrome PB= polished brass W= factory white	A= AC only, 120 to 347VAC U=120 to 347VAC, 6 to 24VDC I= Self-Powered diagnostic, 120/347VAC D= Self-Powered, 120 to 347VAC* D2= Self-Powered diagnostic, 120/277VAC NEX= NEXUS® system interface** NEXRF= wireless NEXUS® system interface**	R= red G= green	C= clear single face M= mirror W= white	N= no chevrons AL= chevron left AR= chevron right A= one chevron, double face DA= double chevron, double face	A= angular, universal mount C= circular, universal mount F= flat trim, ceiling mount, recessed only

\* Self-Powered (90 Min time base)  
\*\* Consult your sales representative for options available with the NEXUS® system.

EXAMPLE: EX31WURWA



# EAE Series

Aluminum Slim Edge-Lit  
Pictogram Sign

Project/Location:

Contractor:

Date:

Prepared by:

## FEATURES

- Slim-profile extruded aluminum housing
- Low-profile EZ2 Die-Cast aluminum canopy
- Universal surface mounting – wall, ceiling or end mount
- Click-to-open housing door allows easy access to the panel and electrical wiring
- Extruded acrylic panel with pictogram legend
- Comes with double-face panels for use in single-face and double-face applications
- Long-life white LED light source
- Meets or exceeds CSA.222 No.141-10
- Universal AC input: two-wire 120 to 347VAC; standard DC input: two-wire 6 to 24VDC
- Energy efficient – consumes less than 3W in AC or DC-remote mode
- Self-Powered models provide minimum two hours of emergency lighting



## TYPICAL SPECIFICATIONS

Supply and install the **Emergi-Lite® EAE Series** slim-profile pictogram Edge-Lit Exit Sign. The unit shall operate with universal 2-wire AC input voltage of 120 to 347VAC at less than 3W and universal 2-wire DC input voltage from 6 to 24VDC at less than 2.5W. The housing assembly shall be constructed of extruded aluminum with textured finish and \_\_\_\_\_ colour. The canopy shall be of Die-Cast aluminum and allow for wall, end, or ceiling mount. The legend shall be printed on a pure-acrylic panel. The panel shall come standard with double-face legend, for single-face and double-face applications. The light source shall be long-life white light-emitting diodes (LED) and shall provide even illumination in normal and emergency operation. The pictogram Edge-Lit Exit Sign in a Self-Powered configuration shall use a sealed Nickel-Cadmium battery of 2.4V nominal voltage and shall stay illuminated during emergency operation for at least two hours upon AC failure.

The pictogram Edge-Lit Exit Sign shall be listed CSA 22.2 No.141-10.

The equipment shall be **Emergi-Lite®** Model: \_\_\_\_\_.

## DIMENSIONS

Dimensions are approximate and subject to change.

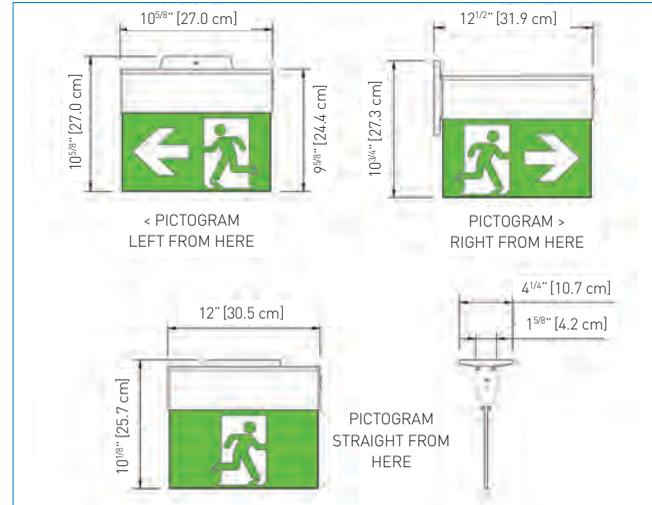

## POWER CONSUMPTION

MODEL	AC SPECS		DC SPECS	
AC-only	120 to 347VAC	Less than 3W	-	-
AC/DC standard	120 to 347VAC	Less than 3W	6 to 24VDC	Less than 2.5W
AC/48VDC	120 to 347VAC	Less than 3W	48VDC	2W
AC/120VDC	120 to 347VAC	Less than 3W	120VDC	4.7W
Two-wire 120V AC/DC	120VAC	Less than 3.5W	120VDC	Less than 3.5W
Self-Powered	120 to 347VAC	Less than 4W	Nickel-Cadmium battery	Minimum 2 hours

## ORDERING INFORMATION

SERIES	FACES / ARROW (UNIVERSAL MOUNTING)	COLOUR	VOLTAGE
EAE= extruded aluminum edge-lit pictogram exit sign	1= one face, no arrow L= single face left arrow R= single face right arrow 2= two faces, no arrow A= two faces, arrow left or right	TA= textured aluminum OW= off-white	AC= 120 to 347VAC only U= 120 to 347VAC; 6 to 24VDC UI= 120 to 347VAC Self-Powered* U48= 120 to 347VAC; 48VDC U120= 120 to 347VAC; 120VDC 2120= 2 wires 120VAC/VDC

\*Self-Powered (90 min. time base)

EXAMPLE: EAE20WAC

Project/Location:

Contractor:

Date:

Prepared by:

# EX3 Series

Aluminum Slim  
Edge-Lit Exit Sign



## FEATURES

- Extruded aluminum housing
- Die-Cast aluminum E22 canopy
- Universal surface mounting: wall, ceiling or end mount
- Click-to-open housing door allows easy access to the panel and electrical wiring
- Acrylic panel with curved contour
- Legend with 6" letters and easy to add-on directional indicators
- Simple, two-wire universal AC input (120V to 347VAC 50/60Hz) prevents installation errors
- Simple, two-wire universal DC input: 6V to 24VDC
- Energy efficient power consumption: less than 1.5W in AC or DC mode
- Meets or exceeds CSA 22.2 No.141-10



## TYPICAL SPECIFICATIONS

Supply and install the **Emergi-Lite® EX3 Series** LED slim-profile Edge-Lit Exit Sign. The unit shall operate with universal two-wire AC input voltage from 120VAC to 347VAC at less than 1.5W and universal two-wire DC input voltage from 6VDC to 24VDC at less than 1.5W for single and double face legends.

The housing assembly shall be fabricated of extruded aluminum with a textured finish and \_\_\_\_\_ colour. The canopy shall be of die-cast aluminum and allow for ceiling, wall, or end mount installation. The light source shall be ten (10) long-life LEDs installed on a PCB strip. Red LED technology shall be **ALINGAP**. The acrylic panel shall have a curved contour.

The legend shall have 6" high, 3/4" stroke red letters on a clear background, unless otherwise specified. The unit shall be equipped with stick-on translucent directional indicators, to be installed in the field as required by the code.

The Exit Sign in a Self-Powered configuration shall be equipped with sealed Nickel-Cadmium batteries and will provide a minimum of 90 minutes of emergency illumination upon AC failure.

The equipment shall be CSA 22.2 No.141-10 approved.

The equipment shall be **Emergi-Lite®** Model: \_\_\_\_\_ .

## POWER CONSUMPTION

MODEL	AC SPECS		DC SPECS	
AC/DC red	120 to 347VAC	Less than 1.5W	6 to 24VDC	Less than 1.5W
AC/DC green	120 to 347VAC	Less than 2W	6 to 24VDC	Less than 1.5W
Self-Powered red	120 to 347VAC	Less than 2.5W	Nickel-Cadmium battery	Min. 90 minutes
Self-Powered green	120 to 347VAC	Less than 3W	Nickel-Cadmium battery	Min. 90 minutes

## DIMENSIONS

Dimensions are approximate and subject to change.

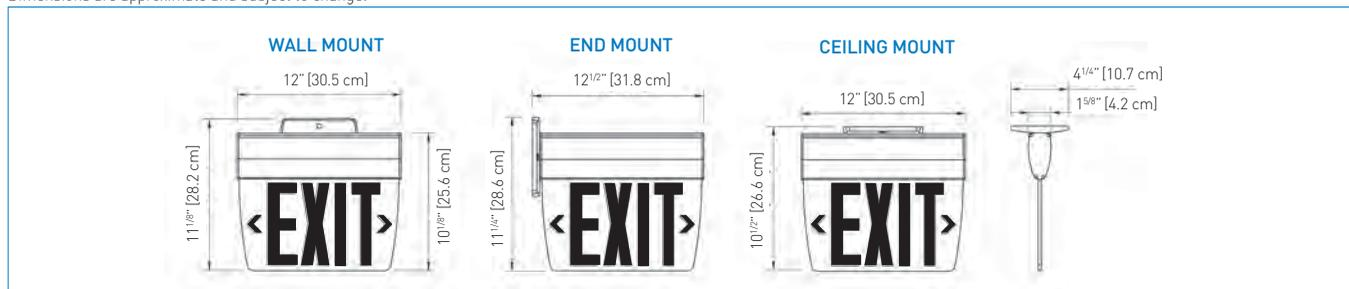

## ORDERING INFORMATION

SERIES/FACES	HOUSING COLOUR	VOLTAGE	FACEPLATE COLOURS
EX38= single face EX39= double face	TA= textured aluminum OW= off-white  Other colours available, Consult your sales representative.	-AC= AC only -U= AC/DC -UI= Self-Powered (90 minutes) -EM120-2W= 120VAC, 120VDC, 2 wires	-RC= red/clear* -RW= red/white -RM= red/mirror -GC= green/clear* -GM= green/mirror  *Not available on double face.

EXAMPLE: EX38TA-U-RC



# C8SR3 Series

Aluminum Slim  
Edge-Lit "Sortie" Sign

Project/Location:	_____
Contractor:	_____
Date:	_____
Prepared by:	_____

## FEATURES

- Extruded aluminum housing
- Slim-Profile cast aluminum canopy
- Universal surface mounting: wall, ceiling or end mount
- Click-to-open housing door allows easy access to the panel and electrical wiring
- Acrylic panel with curved contour
- Legend with 6" letters and easy to add-on directional indicators
- Simple, two-wire universal AC input (120V to 347VAC 50/60Hz) prevents installation errors
- Simple, two-wire universal DC input: 6V to 24VDC
- Long-life LED light source of **ALINGAP** technology assures low maintenance costs
- Energy-efficient power consumption: less than 3W in AC or DC mode
- Self-Powered models provide 90 minutes of emergency illumination
- CSA certified, meets or exceeds CSA 22.2 No. 141 requirements

## TYPICAL SPECIFICATIONS

Supply and install the **Emergi-Lite® C8SR3 Series** LED slim-profile Edge-Lit "Sortie" Sign. The unit shall operate with universal two-wire AC input voltage from 120VAC to 347VAC at less than 2W and universal two-wire DC input voltage from 6VDC to 24VDC at less than 1.5W for single and double face legends.

The housing assembly shall be fabricated of extruded aluminum with a textured finish and \_\_\_\_\_ colour. The canopy shall be of Die-Cast aluminum and allow for ceiling, wall, or end mount installation. The light source shall be fourteen (14) long-life LEDs installed on a PCB strip. Red LED technology shall be **ALINGAP**. The acrylic panel shall have a curved contour.

The legend shall have 6" high, 3/4" stroke red letters on a clear background, unless otherwise specified.

The unit shall be equipped with stick-on translucent directional indicators, to be installed in the field as required by the code. The Exit Sign in a Self-Powered configuration shall be equipped with sealed Nickel-Cadmium batteries and will provide a minimum of 90 minutes of emergency illumination upon AC failure.

The equipment shall be CSA 22.2 No. 141 approved.

The equipment shall be **Emergi-Lite®** Model: \_\_\_\_\_



## POWER CONSUMPTION

MODEL	AC SPECS		DC SPECS	
	AC/DC	120 to 347VAC	Less than 2W	6 to 24VDC
Self-Powered	120 to 347VAC	Less than 3W	Nickel-Cadmium battery	Min. 90 minutes

## DIMENSIONS

Dimensions are approximate and subject to change.



## ORDERING INFORMATION

SERIES	HOUSING COLOUR	VOLTAGE	FACEPLATE COLOURS
C8SR38= single face C8SR39= double face	TA= textured aluminum OW= off-white  Other colours available. Consult your sales representative.	-AC= AC only -U= universal (AC/DC) -UI= Self-Powered (90 Minutes)	-RC= red/clear* -RW= red/white -RM= red/mirror  *Single face only.

EXAMPLE: C8SR38TA-AC-RC

Project/Location:

Contractor:

Date:

Prepared by:

# EX3F Series

## Low-Profile Recessed Edge-Lit Exit Sign



### FEATURES

- Rugged, 20-gauge steel back box
- Equipped with bar hanger kit for easy installation
- Formed steel flat trim plate
- Choice of finishes: textured aluminum or off-white
- Acrylic panel with curved contour provides superior clarity and illumination
- Legend with 6" letters and easy to add-on directional chevrons
- Choice of legend background: clear, white or mirror
- Simple, two-wire universal AC input (120V to 347VAC 50/60Hz) prevents installation errors
- Simple, two-wire universal DC input: 6V to 24VDC
- Long-life LED light source of **ALINGAP** technology assures low maintenance costs
- Energy-efficient power consumption: less than 1.5W in AC or DC mode
- Self-Powered models provide 90 minutes of emergency illumination
- CSA certified, meets or exceeds C860-01 and NRCAN/C860-01 requirements
- Meets or exceeds CSA22.2 No. 141-10



### DIMENSIONS

Dimensions are approximate and subject to change.

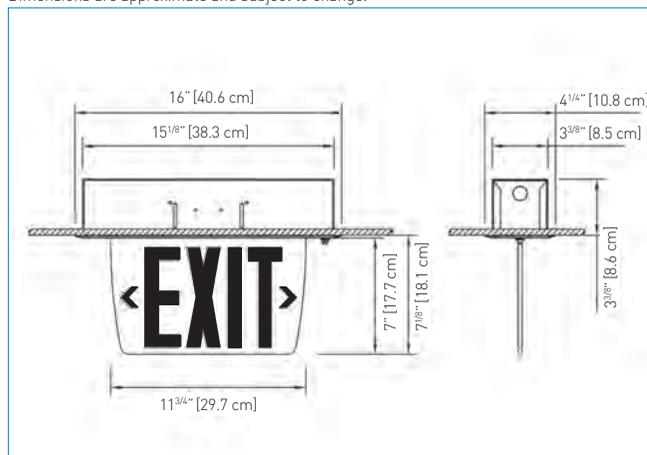

### TYPICAL SPECIFICATIONS

The **Emergi-Lite® EX3F Series** combines a low-profile modular design with state-of-the-art technology and ease of installation. Elegantly discreet, these Exit Signs complement interior designs while providing mounting versatility and energy efficiency.

Supply and install the **Emergi-Lite® EX3F Series** LED low-profile recessed Edge-Lit Exit Sign. The unit shall operate with universal two-wire AC input voltage from 120VAC to 347VAC at less than 1.5W and universal two-wire DC input voltage from 6VDC to 24VDC at less than 1.5W for single and double face legends. The housing assembly shall be of rugged 20-gauge steel and shall include a bar hanger kit for easy installation. The trim plate shall be low-profile and manufactured of formed steel with a textured finish and \_\_\_\_\_ colour. The light source shall be eight (8) long-life LEDs installed on a PCB strip. Red LED technology shall be **ALINGAP**. The whole electrical circuit shall be contained in a plastic housing fixed on the trim plate. The acrylic panel shall have a curved contour. The legend shall have 6" high, 3/4" stroke red letters on a clear background, unless otherwise specified. The unit shall be equipped with stick-on translucent directional indicators, to be installed in the field as required by the Code.

The Exit Sign in a Self-Powered configuration shall be equipped with sealed Nickel-Cadmium batteries and will provide a minimum of 90 minutes of emergency illumination upon AC failure.

The equipment shall be CSA-C860 and NRCAN/C860-01 approved. CSA22.2 No. 141-10

The equipment shall be **Emergi-Lite®** Model: \_\_\_\_\_.

### POWER CONSUMPTION

MODEL	AC SPECS		DC SPECS	
	AC-only	120 to 347VAC	Less than 1.5W	-
AC/DC-remote	120 to 347VAC	Less than 1.5W	6 to 24VDC	Less than 1.5W
Self-Powered	120 to 347VAC	Less than 2.5W	Nickel-Cadmium battery	Min. 90 minutes

### ORDERING INFORMATION

SERIES / FACES	HOUSING COLOUR	VOLTAGE	PANEL COLOUR
EX38F= single face EX39F= double face	TA= textured aluminum OW= off-white	-U= AC/DC -AC= AC Only -UI= Self-Powered (90 Minutes)	-RC= red/clear* -RW= red/white -RM= red/mirror -GC= green/clear* -GM= green/mirror

\*Single face only.

EXAMPLE: EX38FTA-U-RC



# C8SR35 Series

Edge-Lit "Sortie" Sign

Project/Location: \_\_\_\_\_

Contractor: \_\_\_\_\_

Date: \_\_\_\_\_

Prepared by: \_\_\_\_\_

## FEATURES

- Universal back box designed for surface or recessed mounting on ceilings or walls
- Modular retainer clips allow "snap-in" installation of face panel after installation of back box
- Extruded acrylic panels with precision-etched lettering legend
- LED strip design allows for rotation for either ceiling or wall mounting
- Long-life, energy-efficient **ALINGAP** technology LED light source reduces maintenance and energy costs
- Energy efficient – consumes less than 5W in AC or DC mode
- Meets or exceeds C860 requirements
- Meets or exceeds CSA22.2 No.141-10



## POWER CONSUMPTION

MODEL	AC SPECS		DC SPECS	
AC/DC red	120 to 347VAC	Less than 4.5W	6 to 48VDC	Less than 2.5W
Self-Powered red	120 to 347VAC	Less than 5W	Nickel-Cadmium battery	Min. 60 minutes

## TYPICAL SPECIFICATIONS

Supply and install the **Emergi-Lite® C8SR35 Series** LED "SORTIE" Exit Sign.

The equipment shall operate with universal two-wire AC input voltage from 120VAC to 347VAC at less than 4.5W and universal two-wire DC input voltage from 6VDC to 48VDC at less than 2.5W for single or double face legend. The housing assembly shall be fabricated of die-cast aluminum and consist of a universal die cast aluminum back box. The back box shall be provided with conduit knockouts on top, back, and end. The trim plate shall have a round shape and attach to the housing assembly with two (2) torsion spring retainers, thereby eliminating all visible screws or hardware. The LED light strip shall be contained within the trim plate.

Red LED technology shall be **ALINGAP**. The polished acrylic face panel shall have precision etched 6" high, 3/4" stroke red letters with a white, clear or mirror background. For recessed applications, please contact your regional sales representative .

The Exit Sign in a Self-Powered configuration shall stay illuminated during emergency operation for at least 60 minutes upon AC failure.

The Exit Sign shall be CSA 860 and CSA22.2 No. 141 approved.

The equipment shall be **Emergi-Lite®** Model: \_\_\_\_\_ .

## DIMENSIONS

Dimensions are approximate and subject to change.

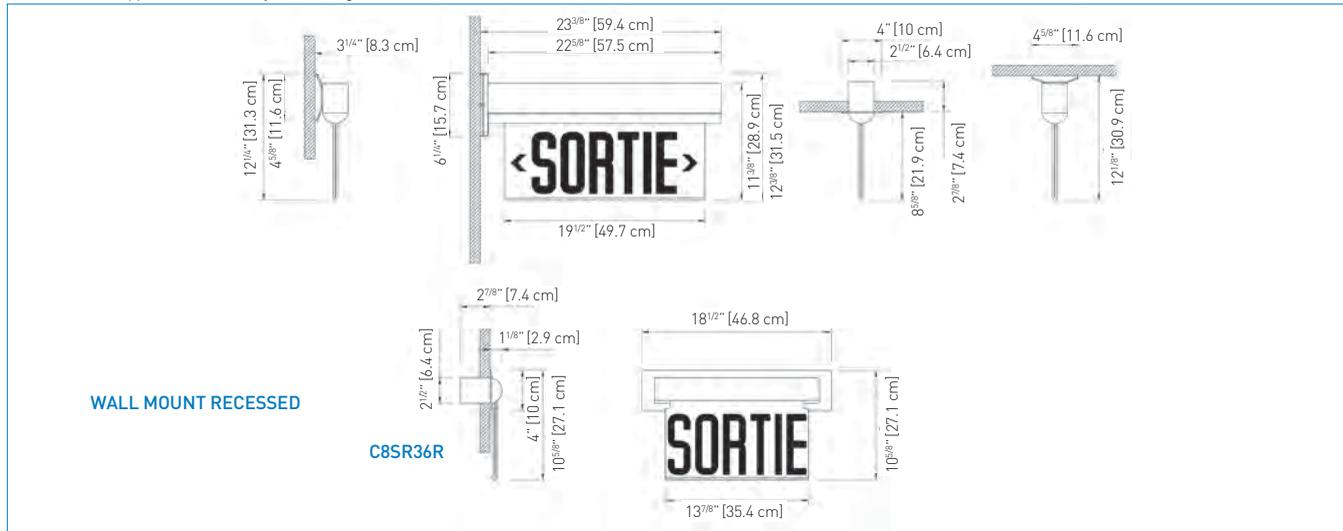

## ORDERING INFORMATION

SERIES	HOUSING COLOUR	SUPPLY	FACEPLATE COLOURS	CHEVRONS
<b>C8SR36</b> = single face <b>C8SR36R</b> = recessed single face wall mount, no chevrons <b>C8SR37</b> = double face	<b>W</b> = factory white <b>BA</b> = brushed aluminum <b>B</b> = black	<b>-U</b> = universal AC/DC <b>-UI</b> = Self-Powered	<b>-RC</b> = red/clear* <b>-RM</b> = red/mirror <b>-RW</b> = red/white	<b>Blank</b> = no chevrons <b>-AL</b> = chevron left* <b>-AR</b> = chevron right* <b>-DA</b> = double chevron <b>-A</b> = one chevron each side, double face
			*Single face only.	*Not available on double face

EXAMPLE: C8SR36W-U-RC

Project/Location:

Contractor:

Date:

Prepared by:

# C8ES35 & C8SE35 Series

## Bilingual Edge-Lit Sign



### FEATURES

- Universal back box designed for surface or recessed mounting on ceilings or walls
- Modular retainer clips allow “snap-in” installation of face panel after installation of back box
- LED Edge-Lit, extruded acrylic face panels with precision-etched lettering
- LED strip design allows for rotation for either ceiling or wall mounting
- Long life, energy-efficient **ALINGAP** technology LED light source reduces maintenance and energy costs
- Energy efficient – consumes less than 8.6W in AC or DC mode
- CSA certified, meets or exceeds CSA 22.2 No. 141 requirements

### POWER CONSUMPTION

MODEL	AC SPECS		DC SPECS	
AC/DC red	120 to 347VAC	Less than 8.6W	6 to 48VDC	Less than 4.5W
Self-Powered red	120 to 347VAC	Less than 8.6W	Nickel-Cadmium battery	Min. 30 minutes

### TYPICAL SPECIFICATIONS

Supply and install the **Emergi-Lite® C8ES35 or C8SE35 Series** LED Edge-Lit sign. The equipment shall operate with universal two-wire AC input voltage from 120VAC to 347VAC at less than 8.6W and universal 2-wires DC input voltage from 6VDC to 48VDC at less than 4.5W for single and double face signs. The housing assembly shall be fabricated of aluminum and consist of a universal aluminum back box. The back box shall be provided with conduit knockouts on top and back. The trim plate shall have a round shape and shall attach to the housing assembly with two (2) torsion spring retainers thereby eliminating all visible hardware. The LED light strip shall be contained within the trim plate. Red LED technology shall be **ALINGAP**.

The polished acrylic face panel shall have precision-etched 6” high, 3/4” stroke red letters with a white, clear or mirror background, with the words EXIT and SORTIE side by side.

The Exit Sign in a Self-Powered configuration shall stay illuminated during emergency operation for at least 30 minutes upon AC failure.

The Exit Sign shall be CSA-C860 and CSA22.2 No. 141 approved.

The equipment shall be **Emergi-Lite®** Model: \_\_\_\_\_.



### DIMENSIONS

Dimensions are approximate and subject to change.

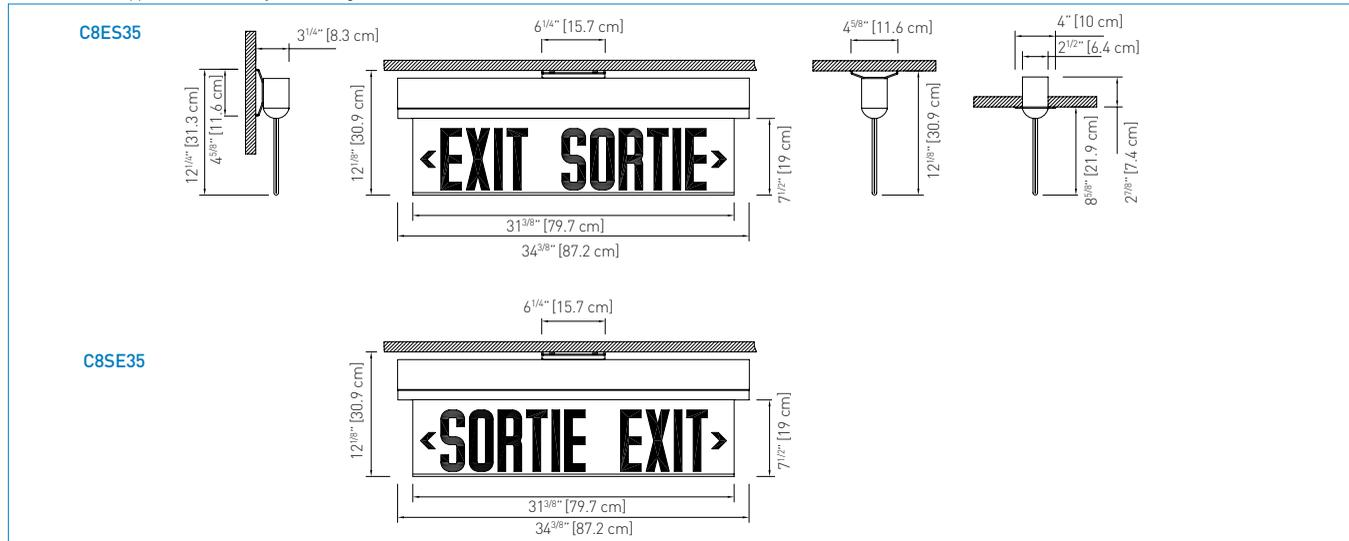

### ORDERING INFORMATION

SERIES	FACES	HOUSING COLOUR	POWER SOURCE	FACEPLATE COLOUR	CHEVRONS
C8ES= exit sortie C8SE= sortie exit	36= single face 37= double face 36R= recessed, single face* 37R= recessed, double face*	W= factory white BA= brushed aluminum B= black	-U= universal AC/DC, 6 to 48VDC -I= Self-Powered, 120/347VAC	-RC= red/clear* -RM= red/mirror -RW= red/white	Blank= no chevrons -AL= chevron left -AR= chevron right -DA= double chevrons -A= one chevron each side, double face
	*Consult your sales representative			*Not available on double face.	

EXAMPLE: C8ES36W-I-RC



# C8E/S35R Series

Bilingual Square Edge-Lit Sign

Project/Location:	_____
Contractor:	_____
Date:	_____
Prepared by:	_____

## FEATURES

- The Edge-Lit front panels are fabricated of extruded acrylic, with precision etched lettering
- Normal AC operation and emergency DC operation: 120-347VAC and 6-48VDC
- Also available in a Self-Powered configuration
- Long life, energy-efficient **ALINGAP** technology LED light source reduces maintenance and energy costs
- Meets or exceeds C860 requirements
- Meets or exceeds CSA 22.2 No. 141 requirements

## TYPICAL SPECIFICATIONS

Supply and install the **Emergi-Lite® C8E/S35R Series** LED Edge-Lit bilingual Exit Sign. The equipment shall operate with universal two-wire AC input voltage from 120VAC to 347VAC at less than 4W and universal two-wire DC input voltage from 6VDC to 48VDC at less than 2W for single or double face signs.

The housing assembly shall be fabricated of Die-Cast aluminum and consist of a universal die cast aluminum back box. The back box shall be provided with conduit knockouts on top and in the back.

The trim plate shall have an angular (prismatic) shape and attach to the housing assembly with two (2) torsion spring retainers thereby eliminating all visible hardware.

The LED light strip shall be contained within the trim plate. Red LED technology shall be **ALINGAP**. The polished acrylic face panel shall have precision etched 6" high, 3/4" stroke red letters with a white, clear or mirror background, with the text "EXIT" and "SORTIE" positioned one on top of the other. When directional chevrons are specified, they will be printed next to the word "EXIT".

The Exit Sign specified for recessed applications will be supplied with a flat trim plate.

The bilingual Exit Sign in a Self-Powered configuration shall stay illuminated during emergency operation for at least 30 minutes upon AC failure.

The Exit Sign shall be CSA-C860 approved and meets CSA 22.2 No. 141. The equipment shall be **Emergi-Lite®** Model: \_\_\_\_\_.



## POWER CONSUMPTION

MODEL	AC SPECS		DC SPECS	
AC/DC red	120 to 347VAC	Less than 3W	6 to 48VDC	Less than 1.5W
Self-Powered red	120 to 347VAC	Less than 3W	Nickel-Cadmium battery	Min. 30 minutes

## DIMENSIONS

Dimensions are approximate and subject to change.

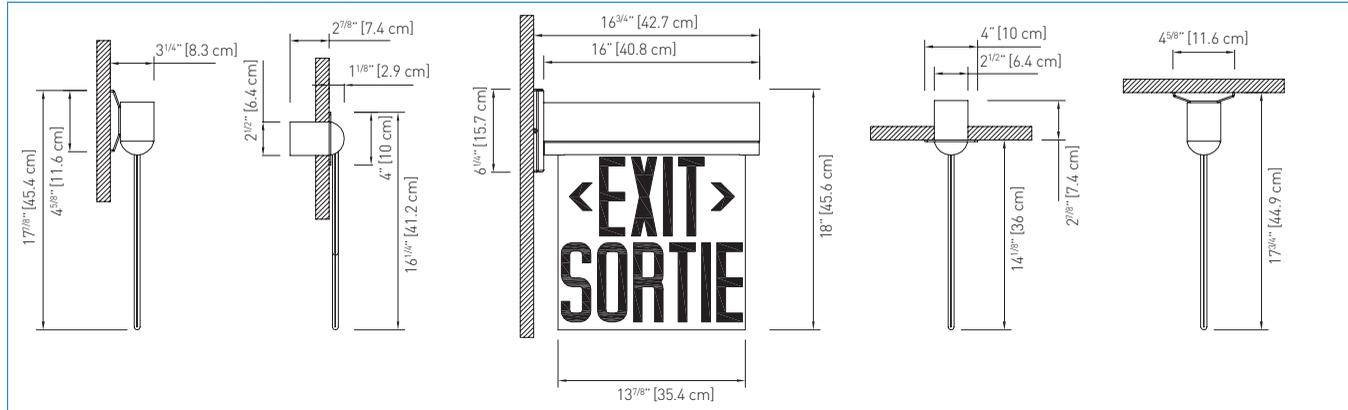

## ORDERING INFORMATION

SERIES	FACES	HOUSING COLOUR	POWER SOURCE	FACEPLATE COLOUR	CHEVRONS
C8ES= exit/sortie C8SE= sortie/exit	36B12= single face 37B12= double face	W= factory white BA= brushed aluminum B= black	Blank= universal AC/DC to 48VAC -I= Self-Powered 120/347 VAC	RC= red/clear* RW= red/white RM= red/mirror	Blank= no chevrons -AL= chevron left -AR= chevron right -DA= double chevron -A= one chevron, each side double face

\*Not available on double face.

EXAMPLE: C8E/S36RW-RC-AL

Project/Location:

Contractor:

Date:

Prepared by:

# PRE Series

## Die-Cast LED Exit Sign



### FEATURES

- Housing of Die-Cast aluminum in a variety of finishes
- Slim-line canopy for top and end mounting
- Universal mounting or wall, end, or ceiling mounting
- Universal, field-selectable knock-out chevrons
- Long-life LED light source. Red LED's of **ALINGAP** technology
- Dual voltage input: 120/347VAC 60Hz
- Low power consumption: less than 3.5W in any configuration
- Self-Powered models with sealed maintenance-free Nickel-Cadmium batteries
- Meets or exceeds CSA 22.2 No. 141 requirements
- Five-year full warranty



### DIMENSIONS

Dimensions are approximate and subject to change.

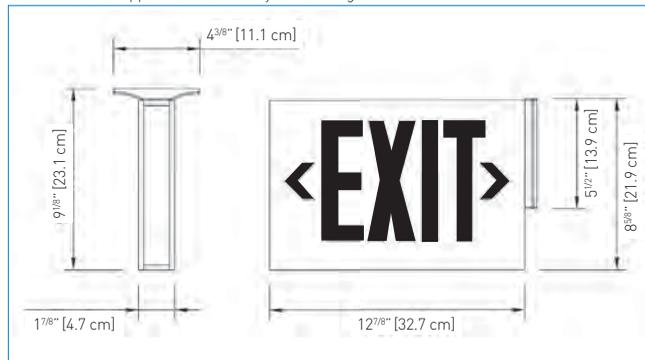

### TYPICAL SPECIFICATIONS

Stylish, built of Die-Cast aluminum, the new **PRE Series** offers superior workmanship, versatile mounting capabilities and economical, long-lasting LED performance.

Supply and install the **Emergi-Lite® PRE Series** Exit Sign. The frame, face plate(s), back plate and canopy shall be constructed of Die-Cast aluminum of \_\_\_\_\_ finish and \_\_\_\_\_ color. No screws are necessary to hold the faceplate(s) or the back plate to the housing. The unit shall be suitable for installation on wall, end, or ceiling mount. The faceplates shall come standard with knockout chevrons. The light source shall be light emitting diodes (LEDs). Red LED technology shall be **ALINGAP**. The LEDs shall provide illumination in normal and emergency operation and shall be mounted inside the exit housing, not on the face. An LED-sensitive diffuser shall be mounted in front of the LEDs to provide the 6" high by 3/4" stroke letters with even illumination. The Exit Sign in a Self-Powered configuration shall be equipped with a sealed, maintenance-free Nickel-Cadmium battery. The equipment shall operate with a dual-voltage input of 120/347VAC 60Hz with less than 3.5W of consumption. The equipment shall stay illuminated at least 90 minutes upon AC failure. The Exit Sign shall be listed to UL924 standard and be approved for use in damp locations. When specified, the Self-Powered model equipped with advanced diagnostic shall self-test by simulating a power failure for one minute every 30 days, 30 minutes every 60 days and 90 minutes every 360 days. A diagnostic circuit shall continuously monitor the performance of the battery, charger module and LED lamps. Upon failure detection the system shall display the error on the AC pilot lamp, which will change color from green to red and will flash with a specific code. The red light shall be steady-on in case of "Battery Disconnect"; it shall flash with one blink for "Battery failure", two blinks for "Charger failure" and four blinks for "LED lamp failure". A label with the diagnostic legend shall be visible next to the pilot light.

The Exit Sign shall be **Emergi-Lite®** Model: \_\_\_\_\_.

### POWER CONSUMPTION

MODEL	AC SPECS		DC SPECS	
AC only	120/347VAC	Less than 3W	-	-
AC/DC remote	120/347VAC	Less than 3W	6 to 48VDC	Less than 1.5W
Self-Powered	120/347VAC	Less than 3.5W	Nickel-Cadmium battery	Minimum 90 minutes
Self-Powered with diagnostic	120/347VAC	Less than 3W	Nickel-Cadmium battery	Minimum 90 minutes

### ORDERING INFORMATION

SERIES	ENCLOSURE COLOUR	UNIT TYPE	VOLTAGE	LEGEND COLOUR	OPTIONS
<b>PRED</b> = LED die cast	<b>BA</b> = black/ brushed aluminum <b>A</b> = brushed aluminum <b>WA</b> = white/ brushed aluminum <b>W</b> = factory white <b>B</b> = black	<b>AC</b> = AC only <b>AC2C1</b> = dual AC circuit (2 x 120V) <b>UD</b> = 120/277 or 120/347VAC & 6 to 48VDC <b>IDN</b> = Self-Powered diagnostic Nickel-Cadmium (90 Min) <b>IN</b> = Self-Powered Nickel-Cadmium (90 Min) <b>NEX</b> = NEXUS® system interface (90 Min)* <b>NEXRF</b> = NEXUS® wireless system interface (90 Min)*	<b>Blank</b> = dual AC circuit only <b>2</b> = 120/277VAC <b>3</b> = 120/347VAC	<b>R1</b> = single face red <b>R2</b> = double face red <b>G1</b> = single face green <b>G2</b> = double face green	<b>-TP</b> =tamper-proof screws <b>-VRTP</b> = vandal resistant shield with tamper-proof screws*

\*Consult your sales representative for options available with the NEXUS® system.

\*Indicate single or double face

EXAMPLE: PREDAAC2R1



# Prestige™ LPEX100 Series

Die-Cast Aluminum Exit Sign

Project/Location: \_\_\_\_\_

Contractor: \_\_\_\_\_

Date: \_\_\_\_\_

Prepared by: \_\_\_\_\_

## FEATURES

- Slim contoured body design with brushed aluminum faceplate (single or double face option)
- Durable powder-coated Die-Cast construction
- Energy efficient - consumes less than 3W
- Universal mounting – wall, end or ceiling mounting
- Long-life, energy-efficient **ALINGAP** technology LED light source reduces maintenance and energy costs
- Diagnostic/self-test feature comes standard on all Self-Powered models
- 100% bright, even illumination in both normal and emergency operation
- Maintenance-free, long-life sealed nickel cadmium battery
- Normal AC and emergency DC operation – 120 to 347V universal AC input; 6 to 48V universal DC input
- NEXUS® compatible (for more information on NEXUS®, please consult your sales representative)
- CSA certified meets or exceeds CSA 22.2 No. 141 requirements



nexus®

## DIMENSIONS

Dimensions are approximate and subject to change.

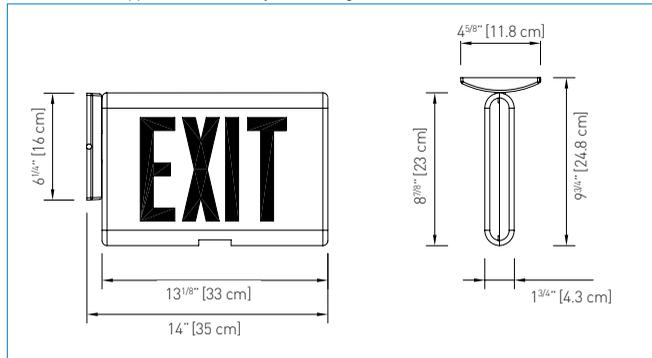

## TYPICAL SPECIFICATIONS

Supply and install the **Emergi-Lite® LPEX100 Series** LED Exit Signs. The equipment shall operate with universal two-wire AC input voltage from 120VAC to 347VAC at less than 3W and universal two-wire DC input voltage from 6VDC to 48VDC at less than 1.5W for single and double face signs. The faceplate(s) and the back plate shall snap together and shall be made of Die-Cast aluminum. The light source shall be light emitting diodes (LED). The LED lamps shall provide illumination in normal and emergency operation and shall be mounted inside the exit on a plastic frame/reflector. Red LED technology shall be **ALINGAP**. An LED-sensitive diffuser shall be mounted behind the legend to provide the 6" high by 3/4" stroke letters with even illumination.

The Self-Powered model shall stay illuminated during emergency operation for at least 90 minutes (red) and at least 60 minutes (green) upon AC failure. The Self-Powered model shall include self-testing and self-diagnostic functions: the equipment shall automatically test itself for 5 minutes every 30 days, 30 minutes every 60 days and 90 minutes annually. A "Service Required" lamp shall be located near the test switch and flash in the case of a fault detection. A two-LED diagnostic display shall be located inside the equipment and shall be capable of identifying the source of failure that may occur (battery, charger circuitry, or LED lamp failure).

The Exit Sign shall be CSA-C860 approved and meets CSA 22.2 No.141

The equipment shall be **Emergi-Lite®** Model: \_\_\_\_\_.

## WIRE GUARDS

460.0079-E	Wall Mount
460.0027-E	End Mount
460.0028-E	Ceiling Mount

## POWER CONSUMPTION

MODEL	AC SPECS		DC SPECS	
AC/DC red	120/347VAC	Less than 2W	6 to 48VDC	Less than 1.5W
AC/DC green	120/347VAC	Less than 2W	6 to 48VDC	Less than 1.5W
Self-Powered red	120/347VAC	Less than 3W	Nickel-Cadmium battery	Min. 90 minutes
Self-Powered green	120/347VAC	Less than 3W	Nickel-Cadmium battery	Min. 60 minutes

## ORDERING INFORMATION

SERIES	FACEPLATES	HOUSING FACEPLATES COLOURS	MODEL	OPTIONS
LPEX= exit	102= single face, universal mount 103= double face, universal mount	WW= factory white BB= black AA= brushed aluminum CH= all chrome PB= all polished brass BZ= bronze BA= black/brushed aluminum WA= white/brushed aluminum  Other colours available. Consult your sales representative.	U= 120 to 347VAC, 6 to 48VDC ID= 120 to 347VAC Self-Powered c/w auto-diagnostics NEX= NEXUS® wired system interface*	-TP= tamper-proof screws -VRTP= vandal resistant shield with tamper-proof screws* -G= green legend 990.0119-E= tamper-proof bit**  * Indicate single or double face **One bit needed per order.

EXAMPLE: LPEX102BAU-TP

Project/Location:

Contractor:

Date:

Prepared by:

# Prestige™ LPSR100 Series

## Die-Cast Aluminum "Sortie" Sign



### FEATURES

- Durable, powder-coated Die-Cast construction
- Slim contoured body design with brushed aluminum faceplate (single or double face option)
- Diagnostic/self-test feature comes standard on all Self-Powered units
- Universal mounting – wall, end or ceiling mounting
- 100% bright, even illumination in both normal and emergency operation
- Long-life, energy-efficient **ALINGAP** technology LED light source reduces maintenance and energy costs
- Energy efficient – consumes less than 3W
- Maintenance-free, long-life sealed Nickel-Cadmium battery
- Normal AC and emergency DC operation – 120 to 347V universal AC input; 6 to 48V universal DC input
- NEXUS® compatible (for more information on NEXUS®, please consult your sales representative)
- CSA certified, meets or exceeds CSA 22.2 No. 141 requirements



nexus®

### DIMENSIONS

Dimensions are approximate and subject to change.

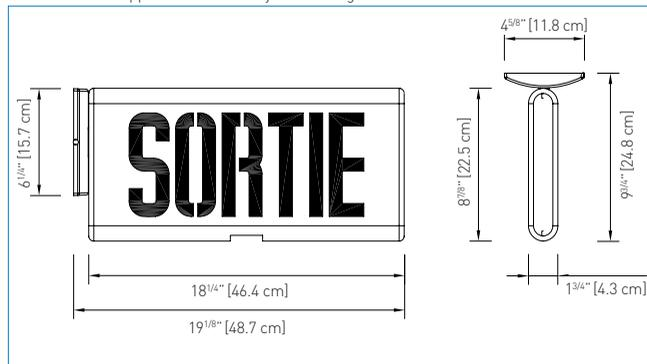

### TYPICAL SPECIFICATIONS

Supply and install the **Emergi-Lite® LPSR100 Series** LED "SORTIE" Exit Signs. The equipment shall operate with universal two-wire AC input voltage from 120VAC to 347VAC at less than 3W and universal two-wire DC input voltage from 6VDC to 48VDC at less than 1.5W for single or double face signs. The faceplate(s) and the back plate shall snap together and shall be made of Die-Cast aluminum. The Exit Sign shall have a maximum depth of 1-3/4".

The light source shall be light emitting diodes (LEDs). The LED lamps shall provide illumination in normal and emergency operation and shall be mounted inside the exit. Red LED technology shall be **ALINGAP**. A LED-sensitive diffuser shall be mounted behind the legend to provide the 6" high by 3/4" stroke letters with even illumination.

The Self-Powered model shall stay illuminated during emergency operation for at least 60 minutes upon AC failure. The Self-Powered model shall include self-testing and self-diagnostic functions: the equipment shall automatically test itself for 5 minutes every 30 days, 30 minutes every 60 days and 90 minutes annually. A "Service" pilot light shall be located near the test switch and flash in the case of a fault detection. A two-LED diagnostic display shall be located inside the equipment and shall be capable of identifying the source of failure (battery, charger circuitry, or LED lamp failure).

The Exit Sign shall be CSA-C860 approved and meets CSA 22.2 No.141 The equipment shall be **Emergi-Lite®** Model: \_\_\_\_\_.

### WIRE GUARDS

460.0057-E	Wall Mount
460.0048-E	End Mount
460.0058-E	Ceiling Mount

### POWER CONSUMPTION

MODEL	AC SPECS		DC SPECS	
	AC/DC	Less than 2W	6 to 48VDC	Less than 1.5W
Self-Powered	120/347VAC	Less than 3W	Nickel-Cadmium battery	Min. 60 minutes

### ORDERING INFORMATION

SERIES	FACEPLATES*	HOUSING FACEPLATES COLOURS	SUPPLY AND VOLTAGE	OPTIONS
LPSR= LED sortie	102= single face 103= double face	WW= white/white BB= black/black WA= white/brushed aluminum BA= black /brushed aluminum AA= brushed aluminum/brushed aluminum CH= chrome/chrome	U= 120VAC to 347VAC, 6VDC to 48VDC ID= 120VAC to 347VDC Self-Powered including auto-diagnostics NEX= NEXUS® wired system interface*	-TP= tamper-proof screws -VRTP= vandal resistant shield with tamper-proof screws* 990.0119-E= tamper-proof bit**
	*Universal mounting	Other colours available.	* Consult your sales representative for options available with the NEXUS® system.	* Indicate single or double face ** One bit needed per order.

EXAMPLE: LPSR102WWU-TP



# LPEX300 Series

Extruded Aluminum Exit Sign

Project/Location: \_\_\_\_\_

Contractor: \_\_\_\_\_

Date: \_\_\_\_\_

Prepared by: \_\_\_\_\_

## FEATURES

- Thin profile, 2-piece extruded aluminum housing
- Pre-specified mounting
- Universal, field-selectable chevrons (knockout)
- Energy efficient – consumes less than 3.5W in AC or DC mode
- Long life **ALINGAP** technology energy-efficient LED light source
- CSA certified, meets or exceeds CSA 22.2, No. 141 and C860 requirements
- Normal AC and emergency DC operation – 120, 277 or 347V AC input; 6 to 24V DC input
- Available in single or double face
- Indirect refractive technology provides bright, even illumination



## DIMENSIONS

Dimensions are approximate and subject to change.

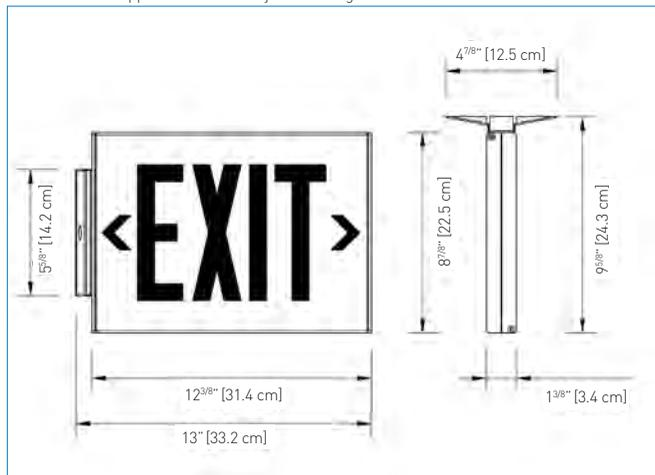

## ORDERING INFORMATION

SERIES	FACEPLATES	COLOUR	MOUNTING	VOLTAGE	OPTIONS
LPEX30= LED EXIT	2= single face 3= double face	W= polar white B= black TA= textured aluminum BA= brushed aluminum	-CM= ceiling mount -EM= end mount -WM= wall mount	-U= 120/277/347VAC, 6 to 24VDC -U36= 120/277/347VAC-36VDC, 4 wires -U48= 120/277/347VAC-48VDC, 4 wires -U120= 120/277/347VAC, 120VDC, 4 wires -8= 240VAC, no DC* -I= 120/347VAC Self-Powered -2I= 120/277VAC Self-Powered -EM120-2W= 120VAC-120VDC -2 wires	-TP= tamper-proof screws 990.0119-E= tamper-proof bit*

\* Consult your sales representative for availability and other DC voltages.      \*One bit needed per order.

EXAMPLE: LPEX302W-CM-UTP

## TYPICAL SPECIFICATIONS

Supply and install the **Emergi-Lite® LPEX300 Series** LED Exit Sign. The equipment shall operate with universal AC input voltage of 120/277 347VAC at less than 1.5W and universal two-wire DC input voltage from 6VDC to 24VDC at less than 1.5W for single and double face signs. The Exit Sign shall consist of a two-piece white extruded aluminum combined body/faceplate with a maximum depth of 1-1/4". The exit shall also include extruded aluminum end caps with white gaskets in order to provide protection to the internal components and eliminate any possible light leaks. The exit fixture shall be either single or double-faced as shown on the drawings. The faceplate shall be of a stencil design and will incorporate 6" high letters with a 3/4" stroke. The canopy shall fasten to the exit body for ease of installation in either ceiling or end mount. The fixture shall contain a light source, which shall be LED with a long life and shall consist of separate AC and DC LED sources in the case of AC/DC-remote equipment. Red LED technology shall be **ALINGAP**.

The Exit Sign in a Self-Powered configuration shall be equipped with a Nickel-Cadmium battery and shall stay illuminated during emergency operation for at least two hours upon AC failure.

The Exit Sign shall be CSA-C860 approved.

The equipment shall be **Emergi-Lite®** Model: \_\_\_\_\_

## WIRE GUARDS

460.0079-E	Wall Mount
460.0027-E	End Mount
460.0028-E	Ceiling Mount

## POWER CONSUMPTION

MODEL	AC SPECS	DC SPECS
AC/DC standard, red	120/277/347VAC Less than 1.5W	6 to 48VDC Less than 1.5W
AC/ special DC, red	120/277/347VAC Less than 1.5W	36 or 48 or 120VDC Less than 3W
120VAC/DC two wires, red	120VAC Less than 3W	120VDC Less than 3W
Self-Powered red	120/347VAC Less than 3.5W	Nickel-Cadmium battery Min. 2 hours

Project/Location:

Contractor:

Date:

Prepared by:

# LPSR300 Series

Extruded Aluminum "Sortie" Sign



## FEATURES

- Thin profile, two-piece extruded aluminum housing simply slides together
- Mounting to be pre-specified
- Standard field-selectable directional knockout chevrons
- Indirect refractive lighting technology provides bright, even illumination
- Long life, energy-efficient **ALINGAP** LED light source
- Energy efficient: consumes less than 3.5W
- Normal AC and emergency DC operation – 120/277/347VAC and 6V to 24VDC input
- CSA certified, meets or exceeds CSA 22.2 No. 141 requirements



## DIMENSIONS

Dimensions are approximate and subject to change.

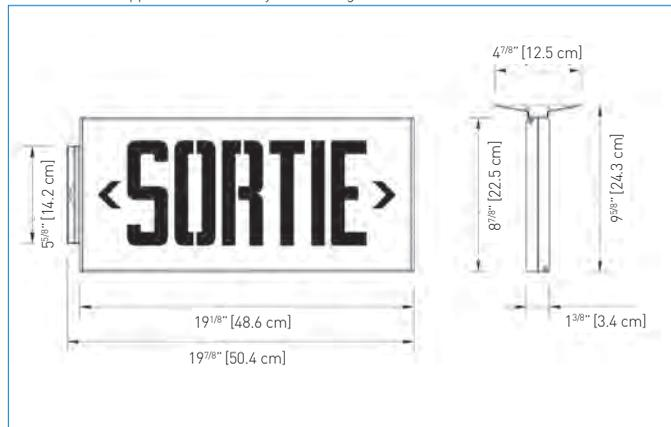

## TYPICAL SPECIFICATIONS

Supply and install the **Emergi-Lite® LPSR300 Series** LED Exit Sign. The equipment shall operate with universal AC input voltage of 120, 277 or 347VAC at less than 1.5W and universal two-wire DC input voltage from 6VDC to 24VDC at less than 1.5W for single and double face signs. The Exit Sign shall consist of a two-piece white extruded aluminum combined body/faceplate with a maximum depth of 1-1/4". The exit shall also include extruded aluminum end caps with white gaskets in order to provide protection to the internal components and eliminate any possible light leaks. The exit fixture shall be either single or double-faced as shown on the drawings. The faceplate shall be of a stencil design and will incorporate 6" high letters with a 3/4" stroke. The canopy shall fasten to the exit body for ease of installation in either ceiling or end to wall mount.

The fixture shall contain a light source, which shall be LED with a long life and shall consist of separate AC and DC LED sources in the case of AC/DC-remote equipment. Red LED technology shall be **ALINGAP**.

The Exit Sign in a Self-Powered configuration shall be equipped with a Nickel-Cadmium battery and shall stay illuminated during emergency operation for at least two hours upon AC failure.

The Exit Sign shall be CSA-C860 approved and meets CSA 22.2 No.141. The equipment shall be **Emergi-Lite®** Model: \_\_\_\_\_.

## WIRE GUARDS

460.0057-E	Wall Mount
460.0048-E	End Mount
460.0058-E	Ceiling Mount

## POWER CONSUMPTION

MODEL	AC SPECS		DC SPECS	
	Voltage	Power	Voltage	Power
AC/DC standard, red	120/277/347VAC	Less than 1.5W	6 to 48VDC	Less than 1.5W
AC/ special DC, red	120/277/347VAC	Less than 1.5W	36/48/120VDC	Less than 3W
120VAC/DC two wires, red	120VAC	Less than 3W	120VDC	Min. 3W
Self-Powered, red	120/347VAC	Less than 3.5W	Nickel-Cadmium battery	Min. 2 hours

## ORDERING INFORMATION

SERIES	FACEPLATES	COLOUR	MOUNTING	SUPPLY VOLTAGE	OPTIONS
LPSR30= SORTIE	2= single face 3= double face	W= polar white B= black TA= textured aluminum BA= brushed aluminum	-CM= ceiling mount -EM= end mount -WM= wall mount	-U= 120/277/347VAC, 6 to 24VDC -U36= 120/277/347VAC, 36VDC -U48= 120/277/347VAC, 48VDC -U120= 120/277/347VAC, 120VDC -I= 120/347VAC Self-Powered -EM120-2W= 120VAC - 120VDC - 2 wires	-TP= tamper-proof screws 990.0119-E= tamper-proof bit*  *One bit needed per order.

EXAMPLE: CS4000WHULTP



# C8ES300 & C8SE300 Series

Bilingual Extruded Aluminum Sign

Project/Location: \_\_\_\_\_

Contractor: \_\_\_\_\_

Date: \_\_\_\_\_

Prepared by: \_\_\_\_\_

## FEATURES

- Thin profile, 2-piece extruded aluminum housing simply slides together
- Pre-specified mounting
- Universal, field-selectable chevrons (knockout)
- Energy efficient – consumes less than 7W in AC or DC mode
- Normal AC and emergency DC operation  
120, 277 or 347V AC input; 6 to 24V DC input
- Available in single or double face
- Custom wording available on request
- Indirect refractive technology provides bright, even illumination
- Long-life **ALINGAP** technology, energy-efficient LED light source
- CSA certified, meets or exceeds CSA 22.2 No. 141 requirements



## TYPICAL SPECIFICATIONS

Supply and install the **Emergi-Lite® C8ES300 Series** LED Exit Sign. The equipment shall operate with universal AC input voltage of 120, 277 or 347VAC at less than 1.5W and universal two-wire DC input voltage from 6VDC to 24VDC at less than 2.5W for single and double face signs. The Exit Sign shall consist of a two-piece white extruded aluminum combined body/faceplate with a maximum depth of 1 1/4". The exit shall also include extruded aluminum end caps with white gaskets in order to provide protection to the internal components and eliminate any possible light leaks. The exit fixture shall be either single or double-faced as shown on the drawings. The faceplate shall be of a stencil design and will have 6" high letters with a 3/4" stroke indicating both EXIT and SORTIE side by side. The canopy shall fasten to the exit body for ease of installation in either ceiling or wall mount. The fixture shall contain a light source, which shall be LED with a long life and shall consist of separate AC and DC LED sources in the case of AC/DC-remote equipment. Red LED technology shall be **ALINGAP**.

The Exit Sign in a Self-Powered configuration shall be equipped with a Nickel-Cadmium battery and shall stay illuminated during emergency operation for at least two hours upon AC failure.

The Exit Sign shall be CSA-C860 approved and meets CSA 22.2 No.141

The equipment shall be **Emergi-Lite®** Model: \_\_\_\_\_.

## POWER CONSUMPTION

MODEL	AC SPECS		DC SPECS	
AC/DC standard, red	120/347VAC	Less than 2W	6 to 48VDC	Less than 3W
AC/ special DC, red	120/277/347VAC	Less than 2W	36 or 48 or 120VDC	Less than 6W
120VAC/DC two wires, red	120VAC	Less than 6W	120VDC	Less than 6W
Self-Powered, red	120 or 347VAC	Less than 7W	Nickel-Cadmium battery	Min. 2 hours

## WIRE GUARDS

460.0059-E	Wall Mount
460.0092-E	Ceiling Mount

## DIMENSIONS

Dimensions are approximate and subject to change.

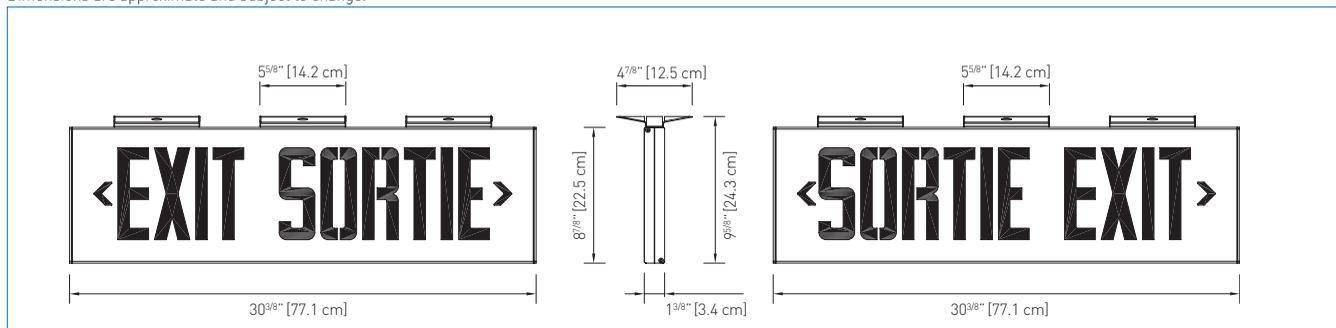

## ORDERING INFORMATION

SERIES	FACES	COLOUR	MOUNTING	VOLTAGE	OPTIONS
C8ES30= exit sortie C8SE30= sortie exit	2= single face 3= double face	W= polar white B= black TA= textured aluminum BA= brushed aluminum	-CM= ceiling mount -WM= wall mount	-U= 120/277/347VAC, 6 to 24VDC -U36= 120/277/347VAC-36VDC -U48= 120/277/347VAC-48VDC -U120= 120/277/347VAC-120VDC -I= 120VAC, Self-Powered -3I= 347VAC, Self-Powered -EM120-2W= 120VAC-120VDC-2 wires	-TP= tamper-proof screws 990.0119-E= tamper-proof bit*  *One bit needed per order.

EXAMPLE: C8ES302W-CM-UTP

Project/Location:

Contractor:

Date:

Prepared by:

# EA Series

## Extruded Aluminum Pictogram Sign



### FEATURES

- Durable extruded, one-piece aluminum housing and face plates
- White LED light source
- Supplied standard with two pictogram films per face, for direction selection
- Meets or exceeds CSA 22.2 No.141-10 standard for pictogram exit signs
- Universal AC input: two-wire 120 to 347VAC; standard DC input: two-wire 6 to 24VDC
- Energy efficient – consumes less than 2.5W in AC or DC-remote mode
- Self-Powered model gives standard two hours of back-up lighting
- Universal mounting – end, wall or ceiling
- Easy access to wiring entry for all mounting options
- Comes standard with the **Emergi-Lite®** EZ2 canopy for quick and easy installation

### TYPICAL SPECIFICATIONS

Supply and install the **Emergi-Lite® EA Series** pictogram Exit Signs. The equipment shall operate with universal 2-wire AC input voltage of 120 to 347VAC at less than 2.5W and universal 2-wire DC input voltage from 6 to 24VDC at less than 1.5W for single and double face signs. The equipment shall be suitable for wall, end, or ceiling mount. The housing shall be constructed of rugged extruded aluminum and have a maximum depth of 2-1/2". The faceplate(s) shall be constructed of extruded aluminum and shall incorporate a protective clear polycarbonate panel. Each face plate shall come standard with two legend films for pictogram and direction selection. The light source shall be white light-emitting diodes (LED) and shall provide even illumination in normal and emergency operation. The pictogram Exit Sign in a Self-Powered configuration shall use a sealed Nickel-Cadmium battery of 2.4V nominal voltage and shall stay illuminated during emergency operation for at least two hours upon AC failure.

The pictogram Exit Sign shall meet CSA 22.2 No.141-10.

The equipment shall be **Emergi-Lite®** Model: \_\_\_\_\_.



### WIRE GUARDS

460.0079-E	Wall mount
460.0027-E	End mount
460.0028-E	Ceiling mount

### DIMENSIONS

Dimensions are approximate and subject to change.

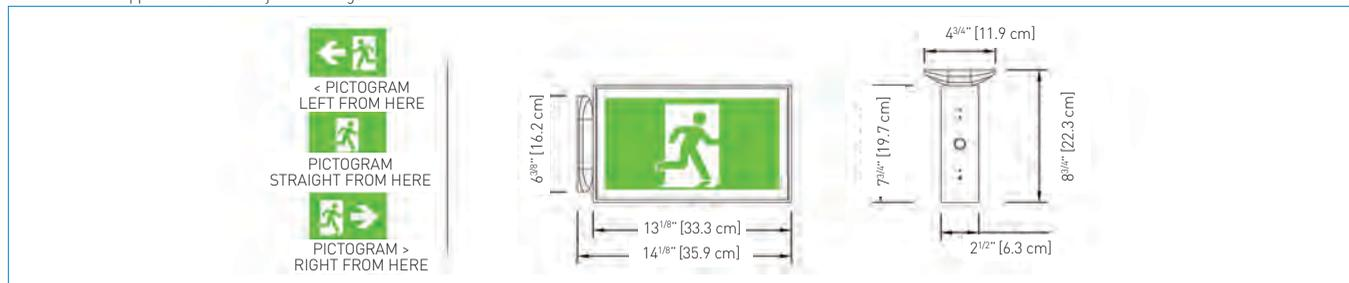

### POWER CONSUMPTION

MODEL	AC SPECS		DC SPECS	
AC-only	120 to 347VAC	Less than 2.5W	-	-
AC/DC standard	120 to 347VAC	Less than 2.5W	6 to 24VDC	Less than 1.5W
AC/Special DC	120 to 347VAC	Less than 2.5W	36, 48, 120VDC	Less than 2.5W
Two-wire 120V AC/DC	120VAC	Less than 2.5W	120VDC	Less than 2.5W
Self-Powered	120 to 347VAC	Less than 3W	Nickel-Cadmium battery	Minimum two hours

### ORDERING INFORMATION

SERIES	FACES / MOUNTING	COLOURS	VOLTAGE		OPTIONS
EA= pictogram Exit Sign	1= single face universal mount 2= double face universal mount 3= single/double face universal mounting	W= factory white B= black G= grey BA= brushed aluminum  Other colours available	U= 120 to 347VAC; 6 to 24VDC I= 120 to 347VAC; Self-Powered/2 hours U00= 120 to 347VAC only U36= 120 to 347VAC; 36VDC U48= 120 to 347VAC; 48VDC U120= 120 to 347VAC;120VDC 2120= 2-wires 120VAC/VDC	IDN= Self-Powered diagnostics, non audible NEX= NEXUS® system interface (90 Min)* NEXRF= NEXUS® wireless system interface (90 Min)*  *Consult your sales representative for options available with the NEXUS® system.	-TP= tamper-proof screws -VR= vandal-resistant shield and tamper-proof screws 990.0119-E= tamper-proof bit*  *One bit per order. Sold separately.

EXAMPLE: EA1WUTP



# LPEX50 Series

Extruded Aluminum  
Exit Sign

Project/Location:

Contractor:

Date:

Prepared by:

## FEATURES

- Durable, extruded, one-piece aluminum housing
- Long-life, energy-efficient **ALINGAP** technology red LED light source completely enclosed in acrylic module
- Single illumination module lights both single and double face exit signs
- Highly energy efficient – consumes less than 2.5W in AC or DC mode
- Normal AC and emergency DC operation – 120/277/347V AC input; 6 to 24V DC input
- Comes with the **Emergi-Lite**® EZ2 canopy for quick and easy installation
- Also available with power pack; see LPEX50-P catalogue sheet
- CSA certified, meets or exceeds CSA 22.2 No. 141 requirements

## DIMENSIONS

Dimensions are approximate and subject to change.

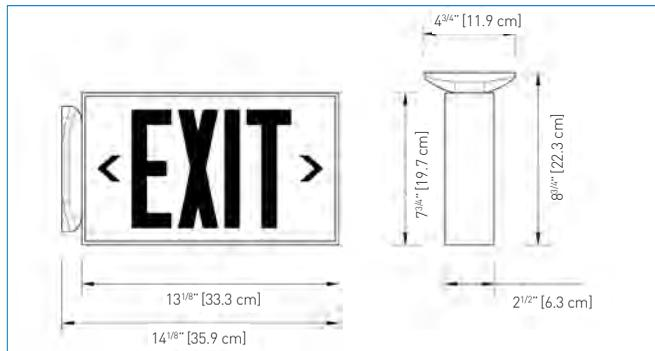

## TYPICAL SPECIFICATIONS

Supply and install the **Emergi-Lite**® LPEX50 Series LED Exit Signs. The equipment shall operate with universal AC input voltage of 120VAC, 277VAC or 347VAC at less than 1.5W and universal two-wire DC input voltage from 6VDC to 24VDC at less than 1.5W for single or double face signs.

The housing shall be constructed of rugged extruded aluminum and have a maximum depth of 2-1/2". The faceplate(s) shall be constructed of extruded aluminum and come standard with knockout chevrons.

The light source shall be light emitting diodes (LED). The LED lamps shall provide illumination in normal and emergency operation and shall be mounted inside the exit housing, not on the face. The red LED technology shall be **ALINGAP**. An LED-sensitive diffuser shall be mounted behind the legend to provide the 6" high by 3/4" stroke letters with even illumination. The Exit Sign in a Self-Powered configuration shall stay illuminated during emergency operation for at least 90 minutes upon AC failure.

The Exit Sign shall be CSA-C860 approved and meets CSA 22.2 No.141

The equipment shall be **Emergi-Lite**® Model: \_\_\_\_\_ .



## WIRE GUARDS

460.0079-E	Wall Mount
460.0027-E	End Mount
460.0028-E	Ceiling Mount

## POWER CONSUMPTION

MODEL	AC SPECS		DC SPECS	
AC/ standard DC, red	120/277/347VAC	Less than 1.5W	6 to 24VDC	Less than 1.5W
AC/ special DC, red	120/277/347VAC	Less than 1.5W	36 or 48 or 120VDC	Less than 2.5W
Self-Powered, red	120 to 347VAC	Less than 3W	Nickel-Cadmium battery	Minimum 90 minutes
AC/ standard DC, green	120 to 347VAC	Less than 1.5W	6 to 24VDC	Less than 1.5W
Self-Powered, green	120 to 347VAC	Less than 3W	Nickel-Cadmium battery	Minimum 90 minutes

## ORDERING INFORMATION

SERIES	FACES	COLOUR	MOUNTING	OPTIONS
LPEX5= LED EXIT	2= single face, universal mount 3= double face, universal mount	W= factory white B= black BA= brushed aluminum TA= textured aluminum W= polar white	-U= 120/277/347VAC, 6 to 24VDC -EM120-2W= 120VAC, 120VDC 2 wires -U36= 120/277/347VAC - 36VDC -U48= 120/277/347VAC - 48VDC -U120= 120/277/347VAC - 120VDC -I= 120 to 347VAC Self-Powered	-TP= tamper-proof screws -VRSTP= vandal resistant shield with tamper-proof screws* -G= green legend 990.0119-E= tamper-proof bit**

\*Indicate single or double face.  
\*\*One bit needed per order.

EXAMPLE: LPEX52W-U-VRTP

Project/Location:

Contractor:

Date:

Prepared by:

# C8SR50 Series

Extruded Aluminum "Sortie" Sign



## FEATURES

- Durable, extruded, one-piece aluminum housing
- Long life **ALINGAP** technology LED light source is completely enclosed in acrylic module
- Single illumination module lights both single and double face exit signs
- Highly energy efficient, consumes a maximum of 3W
- Normal AC and emergency DC operation – 120V to 347VAC; 6V to 24VDC input
- Also available with power pack; see C8SR50-P catalogue sheet
- CSA certified, meets or exceeds CSA 22.2 No. 141 requirements
- Includes **Emergi-Lite**® EZ2 mounting bracket included, for quick and easy installation



## DIMENSIONS

Dimensions are approximate and subject to change.

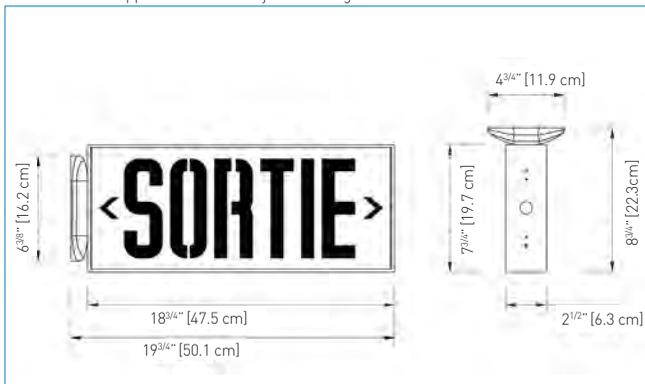

## TYPICAL SPECIFICATIONS

Supply and install the **Emergi-Lite**® C8SR50 Series LED "SORTIE" Exit Signs. The equipment shall operate with universal two-wire AC input voltage of 120VAC to 347VAC at less than 1.5W and universal two-wire DC input voltage from 6VDC to 24VDC at less than 1.5W for single or double face signs.

The housing shall be constructed of rugged extruded aluminum and have a maximum depth of 2-1/2". The faceplate(s) shall be constructed of extruded aluminum and come standard with knockout chevrons.

The light source shall be light emitting diodes (LED). The LED lamps shall provide illumination in normal and emergency operation and shall be mounted inside the exit housing, not on the face. The red LED technology shall be **ALINGAP**. An LED-sensitive diffuser shall be mounted behind the legend to provide the 6" high by 3/4" stroke letters with even illumination. The Exit Sign in a Self-Powered configuration shall stay illuminated during emergency operation for at least 60 minutes upon AC failure.

The Exit Sign shall be CSA-C860 approved.

The equipment shall be **Emergi-Lite**® Model:

## WIRE GUARDS

460.0057-E	Wall Mount
460.0048-E	End Mount
460.0058-E	Ceiling Mount

## POWER CONSUMPTION

MODEL	AC SPECS		DC SPECS	
AC/ standard DC, red	120 to 347VAC	Less than 1.5W	6 to 24VDC	Less than 1.5W
AC/ special DC, red	120/277/347VAC	Less than 1.5W	36 or 48 or 120VDC	Less than 3W
Self-Powered, red	120 to 347VAC	Less than 3W	Nickel-Cadmium battery	Min. 60 or 120 minutes

## ORDERING INFORMATION

SERIES	FACEPLATE & MOUNTING	COLOUR	VOLTAGE	OPTIONS
C8SR5= aluminum SORTIE	2= single face/universal mounting 3= double face/universal mounting	W= factory white B= black TA= textured aluminum W= polar white BA= brushed aluminum	-U= 120/277/347VAC 6 to 24VDC -EM120-2W= 120VAC, 120VDC 2 wires -U36= 120/277/347VAC - 36VDC -U48= 120/277/347VAC - 48VDC -U120= 120/277/347VAC - 120VDC -I= 120/347VAC Self-Powered	-TP= tamper-proof screws -VRTP= vandal resistant shield with tamper-proof screws* -G= green legend 990.0119-E= tamper-proof bit**

\*Indicate single or double face.  
\*\*One bit needed per order.

EXAMPLE: CS5100WH-UL



# LPEX Series

Triangular Extruded  
Aluminum Exit Sign

Project/Location: \_\_\_\_\_

Contractor: \_\_\_\_\_

Date: \_\_\_\_\_

Prepared by: \_\_\_\_\_

## FEATURES

- Rugged extruded aluminum housing
- Extruded aluminum faceplates
- White finish standard
- Standard field-selectable knockout chevrons
- Long life, energy-efficient LED light source
- **ALINGAP** technology LED
- CSA certified, meets or exceeds CSA 22.2 No. 141 requirements



## DIMENSIONS

Dimensions are approximate and subject to change.

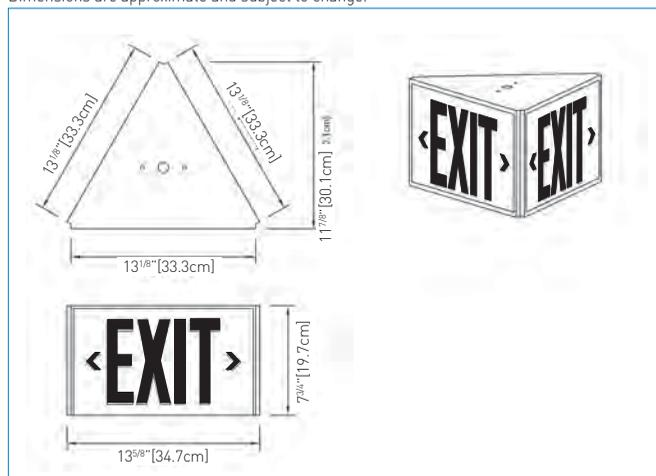

## TYPICAL SPECIFICATIONS

Supply and install the **Emergi-Lite® LPEX Series** of three-face LED Exit Signs. The equipment shall operate with universal AC input voltage of 120, 277 or 347VAC at less than 2W and universal two-wire DC input voltage from 6VDC to 24VDC at less than 3.5W. The housing shall be constructed of rugged extruded aluminum painted with a factory white finish and shall have three face plates oriented symmetrically at 120 degrees in the horizontal plan.

The faceplates shall be constructed of extruded aluminum and come standard with knockout chevrons. The light source shall be red light emitting diodes (LED) of long-life technology **ALINGAP**. An LED-sensitive diffuser shall be mounted behind the legend to provide the 6" high by 3/4" stroke letters with even illumination. Each legend shall be illuminated by one dedicated LED lamp (strip). The LED lamps shall be oriented two downwards and one upwards and shall provide illumination in normal and emergency operation. Eventual failure of one LED lamp shall not affect the well-functioning of the other two lamps. The Exit Sign shall come standard with a pendant kit with a 3/8" diameter pipe for ceiling-mount installation.

The Exit Sign shall be C860 approved and meets CSA 22.2 No.141

The equipment shall be **Emergi-Lite®** Model: \_\_\_\_\_

## POWER CONSUMPTION AND UNIT RATING

MODEL	AC SPECS		DC SPECS	
AC / DC - standard	120/277/347VAC	Less than 2W	6 to 24VDC	Less than 3.5W

## ORDERING INFORMATION

SERIES	FACES/ MOUNTING	COLOUR	VOLTAGE	OPTIONS
LPEX= exit extruded aluminum	55= 2 sided face (Wall mounting only) 56= 3 sided face (Pendant mounting only)	W= factory white	-U= 120/277/347VAC, 6 to 24VDC	-TP= tamper-proof screws 990.0119-E= tamper-proof bit*  *One bit per order.

EXAMPLE: LPEX55W-U

Project/Location:

Contractor:

Date:

Prepared by:

# LPEX54 Series

## Recessed Exit Sign



### FEATURES

- Extruded aluminum faceplate with overlapping trim is standard
- Universal, field-selectable chevrons (knockout)
- Long-life, energy-efficient **ALINGAP** LED light source
- Indirect refractive technology provides bright, even illumination
- Normal AC and emergency DC operation –  
120 to 347V universal AC input;  
6 to 24V two-wire DC input
- Energy efficient – consumes less than 3.5W in AC or DC mode
- Nickel-Cadmium battery provides at least 90 minutes of emergency operation in DC mode
- CSA certified, meets or exceeds CSA 22.2 No. 141 requirements

### DIMENSIONS

Dimensions are approximate and subject to change.

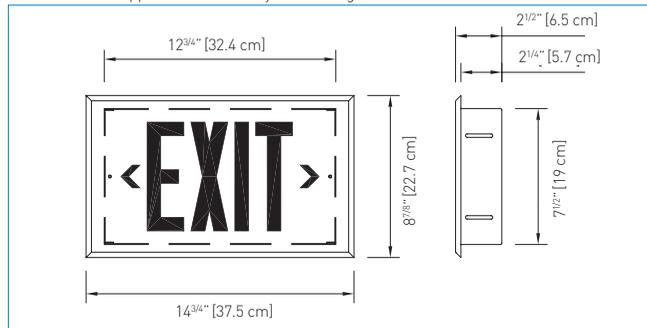

### TYPICAL SPECIFICATIONS

Supply and install the **Emergi-Lite® LPEX54 Series** Exit Sign. The **LPEX54** exit shall be recessed mount. The equipment shall operate with universal AC input voltage of 120, 277 or 347VAC at less than 1.5W and universal two wire DC input voltage from 6VDC to 24VDC at less than 1.5W. The face shall be constructed of extruded aluminum and have an overlapping trim allowing for installation in any location. The faceplate shall come standard with knockout chevrons. The recessed back box shall be of rugged steel construction. The light source shall be light emitting diodes [LED]. Red LED technology shall be **ALINGAP**. The LED lamps shall provide illumination in normal and emergency operation and shall be mounted inside the exit housing, not on the face. An LED sensitive diffuser shall be mounted behind the legend to provide the 6" high by 3/4" stroke letters with even illumination.

The Exit Sign in a Self-Powered configuration shall be equipped with a Nickel-Cadmium battery and shall stay illuminated during emergency operation for at least 90 minutes upon AC failure.

The Exit Sign shall be CSA-C860 approved and meets CSA 22.2 No.141 The equipment shall be **Emergi-Lite®** Model: \_\_\_\_\_ .

### WIRE GUARDS

460.0091-E	Wall Mount
------------	------------

### POWER CONSUMPTION

MODEL	AC SPECS		DC SPECS	
AC/ standard DC, red	120/277/347VAC	Less than 1.5W	6 to 24VDC	Less than 1.5W
AC/ special DC, red	120/277/347VAC	Less than 3W	36 or 48 or 120VDC	Less than 2.5W
Self-Powered, red	120 to 347VAC	Less than 3W	Nickel-Cadmium battery	Minimum 90 minutes
AC/ standard DC, green	120 to 347VAC	Less than 1.5W	6 to 24VDC	Less than 1.5W
Self-Powered, green	120 to 347VAC	Less than 3.5W	Nickel-Cadmium battery	Minimum 90 minutes

### ORDERING INFORMATION

SERIES	COLOUR	VOLTAGE	OPTIONS
LPEX54= LED aluminum recessed EXIT	W= factory white B= black BA= brushed aluminum TA= textured aluminum	-U= 120/277/347VAC, 6 to 24VDC -EM120-2W= 120VAC, 120VDC 2 wires -U36= 120/277/347VAC - 36VDC -U48= 120/277/347VAC - 48VDC -U120= 120/277/347VAC - 120VDC -I= 120 to 347VAC Self-Powered	-TP= tamper-proof screws* -VRTP= vandal resistant shield and tamper-proof screws* -G= green legend 990.0119-E= tamper-proof bit**

\*Indicate single or double face.  
\*\*One bit needed per order.

EXAMPLE: LPEX54B-U-VRTP



# C8ES70 & C8SE70 Series

Bilingual Extruded Aluminum Exit Sign

Project/Location: \_\_\_\_\_

Contractor: \_\_\_\_\_

Date: \_\_\_\_\_

Prepared by: \_\_\_\_\_

## FEATURES

- Durable, extruded, one-piece aluminum housing
- Long-life, energy-efficient **ALINGAP** technology red LED light source completely enclosed in acrylic module
- Single illumination module lights both single and double face Exit Signs
- Highly energy efficient, consumes a maximum of 5.5W in AC or DC mode (standard model)
- Normal AC and emergency DC operation – 120V to 347VAC and 6V to 24VDC input
- CSA certified, meets or exceeds CSA 22.2 No. 141 requirements

## DIMENSIONS

Dimensions are approximate and subject to change.

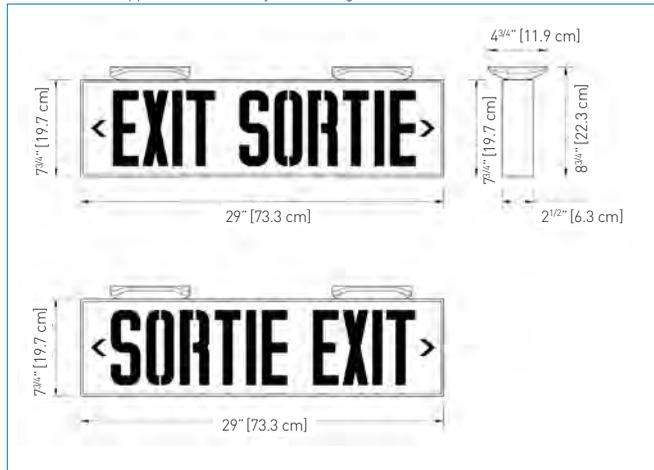

## TYPICAL SPECIFICATIONS

Supply and install the **Emergi-Lite®** bilingual **C8ES70 or C8SE70 Series** LED Exit Sign. The equipment shall operate with universal AC input voltage of 120 to 347VAC at less than 2W and universal two-wire DC input voltage from 6VDC to 24VDC at less than 3.5W for single and double face signs. The housing shall be constructed of rugged extruded aluminum and have a maximum depth of 2-1/2". The faceplate(s) shall be constructed of extruded aluminum and come standard with knockout chevrons. The equipment shall have three (3) canopies that shall fasten for installation in either ceiling- or wall-mount applications. The light source shall be light emitting diodes (LED).

The LED lamps shall provide illumination in normal and emergency operation and shall be mounted inside the exit housing, not on the face. Red LED technology shall be **ALINGAP**. An LED-sensitive diffuser shall be mounted behind the legend to provide the 6" high by 3/4" stroke letters with even illumination.

The Exit Sign in a Self-Powered configuration shall be equipped with a Nickel-Cadmium battery and shall stay illuminated during emergency operation for at least 60 minutes upon AC failure.

The Exit Sign shall be CSA-C860 approved and meets CSA 22.2 No. 141. The equipment shall be **Emergi-Lite®** Model: \_\_\_\_\_.



## WIRE GUARDS

460.0059-E	Wall Mount
460.0092-E	Ceiling Mount

## POWER CONSUMPTION

MODEL	AC SPECS		DC SPECS	
AC/ standard DC, red	120 to 347VAC	Less than 3W	6 to 24VDC	Less than 3.5W
AC/ special DC, red	120/277/347VAC	Less than 5.5W	36 or 48 or 120VDC	Less than 5.5W
Self-Powered, red	120/347VAC	Less than 6W	Nickel-Cadmium battery	Min. 60 or 120 minutes

## ORDERING INFORMATION

LIGHT SOURCE	LETTERING	FACE	COLOUR	POWER SOURCE AND VOLTAGE	OPTIONS
C8= LED	ES= exit sortie 6" letters SE= sortie exit 6" letters	72= single face 73= double face	W= factory white BA= brushed aluminum TA= textured aluminum B= black	-U= 120 to 347VAC, 6 to 24VDC -EM120-2W= 120VAC, 120VDC 2 wires -U36= 120/277/347VAC - 36VDC -U48= 120/277/347VAC - 48VDC -U120= 120/277/347VAC - 120VDC -I= 120 to 347VAC Self-Powered	-TP= tamper-proof screws -VRTP= vandal resistant shield with tamper-proof screws* -90= 90 minutes duration (Self-Powered only) -120= 120 minutes duration (Self-Powered only) 990.0119-E= tamper-proof bit** -3C= 3 canopies

\*Indicate single or double face  
\*\*One bit needed per order.

EXAMPLE: C8ES72W-U-TP

Project/Location: \_\_\_\_\_

Contractor: \_\_\_\_\_

Date: \_\_\_\_\_

Prepared by: \_\_\_\_\_

# ES70B12 & SE70B12 Series

Bilingual Extruded Aluminum Sign



## FEATURES

- Durable, extruded, one-piece aluminum housing
- Long-life, energy-efficient **ALINGAP** technology red LED light source completely enclosed in acrylic module
- Double LED module lights both single and double face Exit Signs
- Highly energy efficient, consumes a maximum of 3W in AC or DC mode (standard model)
- Normal AC and emergency DC operation – 120/277/347VAC and 6V to 24VDC input
- CSA certified, meets or exceeds CSA 22.2 No. 141 requirements



## TYPICAL SPECIFICATIONS

Supply and install the **Emergi-Lite®** bilingual **ES70B12 & SE70B12 Series** LED Exit Sign.

The equipment shall operate with universal AC input voltage from 120 to 347VAC at less than 3W and universal two-wire DC input voltage from 6VDC to 24VDC at less than 3W for single and double face signs. The housing shall be constructed of rugged extruded aluminum and have a maximum depth of 2-1/2". The faceplate(s) shall be constructed of aluminum and come standard with knockout chevrons. The equipment shall have one (1) canopy that shall fasten for installation in either ceiling- or wall-mount applications.

The light source shall be light emitting diodes (LED). The LED lamps shall provide illumination in normal and emergency operation and shall be mounted inside the exit housing, not on the face. Red LED technology shall be **ALINGAP**. An LED-sensitive diffuser shall be mounted behind the legend to provide the 6" high by 3/4" stroke letters with even illumination.

The Exit Sign shall be CSA-C860 approved and meets CSA 22.2 No.141  
The equipment shall be **Emergi-Lite®** Model: \_\_\_\_\_.

## POWER CONSUMPTION

MODEL	AC SPECS		DC SPECS	
AC/ standard DC, red	120 to 347VAC	Less than 3W	6 to 24VDC	Less than 3W

## DIMENSIONS

Dimensions are approximate and subject to change.

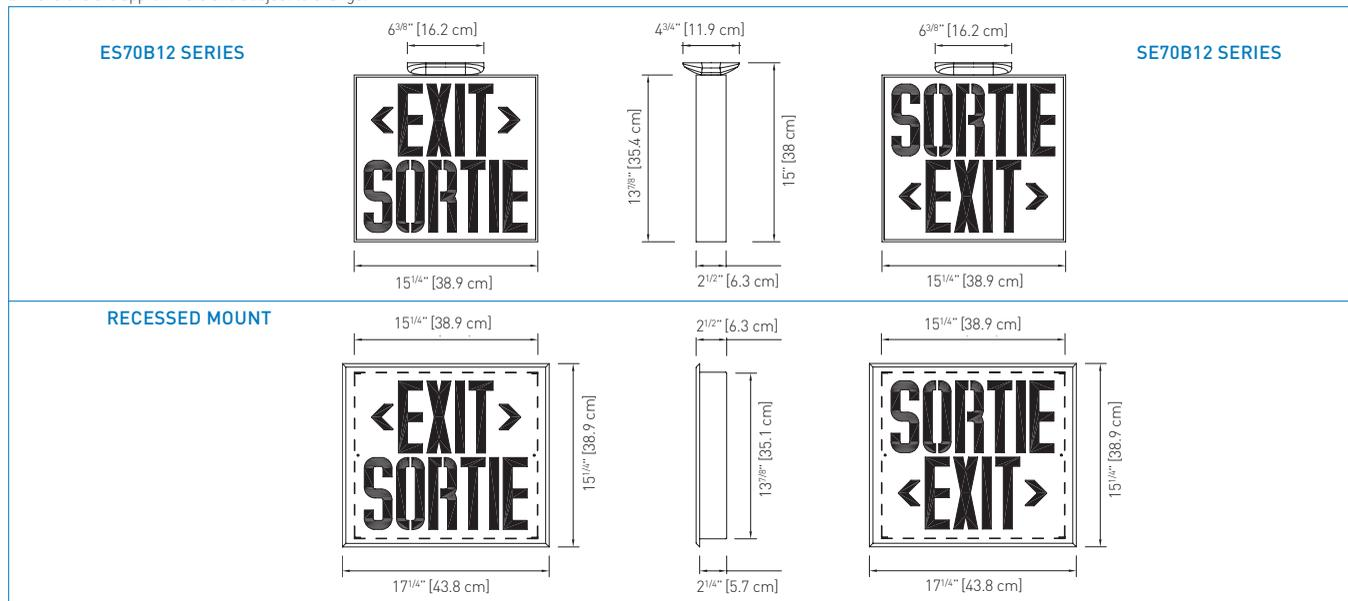

## ORDERING INFORMATION

SERIES	FACES	APPROVAL	COLOUR	POWER SOURCE AND VOLTAGE	OPTIONS
ES= exit sortie SE= sortie exit	72= single face 73= double face	B12	W= factory white B= black TA= textured aluminum  Other colours available. Consult your sales representative.	-U= 120 to 347VAC, 6 to 24VDC -EM120-2W= 120VAC, 120VDC 2 wires -U36= 120/277/347VAC - 36VDC -U48= 120/277/347VAC - 48VDC -U120= 120/277/347VAC - 120VDC -I= 120 to 347VAC Self-Powered	-TP= tamper-proof screws* -VRTP= vandal resistant shield with tamper-proof screws* -R= recessed mount** 990.0119-E= tamper-proof bit*  *One bit needed per order. ** Not available in Self-Powered

EXAMPLE: ES72B12W-U



# EAC Series

Extruded Aluminum  
Combination Unit

Project/Location:	_____
Contractor:	_____
Date:	_____
Prepared by:	_____

## FEATURES

- Solid extruded aluminum construction, painted factory white
- Universal mounting: end, wall or ceiling
- Meets or exceeds CSA 22.2 No.141-10 standard for unit equipment and pictogram safety signs
- Legend illuminated by long-life white LED's
- Comes standard with two pictogram films per face, for direction selection
- 5W LED emergency lights provide 70' of egress illumination on a 6-foot wide path
- Sealed, maintenance-free Lead-Calcium battery
- Remote load capacity: 70' up to 350' of egress illumination when using LED remote heads



nexus®

## TYPICAL SPECIFICATIONS

Supply and install the **Emergi-Lite® EAC Series** combination emergency light battery unit and the pictogram Exit Sign. The unit shall be suitable for universal mounting: wall, end, or ceiling. The unit shall include a power pack made of steel and a legend housing including a one-piece extruded aluminum frame. The legend housing shall have a maximum depth of 2-1/2". The face plate(s) shall be of extruded aluminum and shall incorporate a protective clear polycarbonate panel. Each face plate shall come standard with two legend films for pictogram and direction selection. The light source shall be white light-emitting diodes (LED) and shall provide even illumination in normal and emergency operation. The power pack shall be complete unit equipment with battery charger and rechargeable battery. The battery shall be maintenance-free, sealed Lead-Calcium. In case of AC power failure the equipment shall provide minimum 30 minutes of emergency lighting. The rated DC power available for emergency lights shall be 27W or up to 80W, as specified. The emergency heads shall require no tools to adjust and aim. The heads shall be made of durable thermoplastic construction as otherwise specified.

Units with "auto-diagnostic option" shall include a micro-controller circuit to monitor all the critical functions of the equipment and execute periodical tests of one minute every 30 days, 10 minutes every 6 months and 30 minutes every 12 months. In case of equipment malfunction, an LED-based diagnostic display shall generate a service alarm and indicate the cause of failure: battery, charger circuit, emergency lamps or exit sign lamps.

The equipment shall meet or exceed the requirements of CSA 22.2 No.141-10 standard.

The equipment shall be **Emergi-Lite®** Model: \_\_\_\_\_.

## WIRE GUARDS

460.0081-E	Wall mount
460.0060-E	Ceiling mount

Project/Location:

Contractor:

Date:

Prepared by:

# EAC Series

Extruded Aluminum  
Combination Unit



## DIMENSIONS

Dimensions are approximate and subject to change.

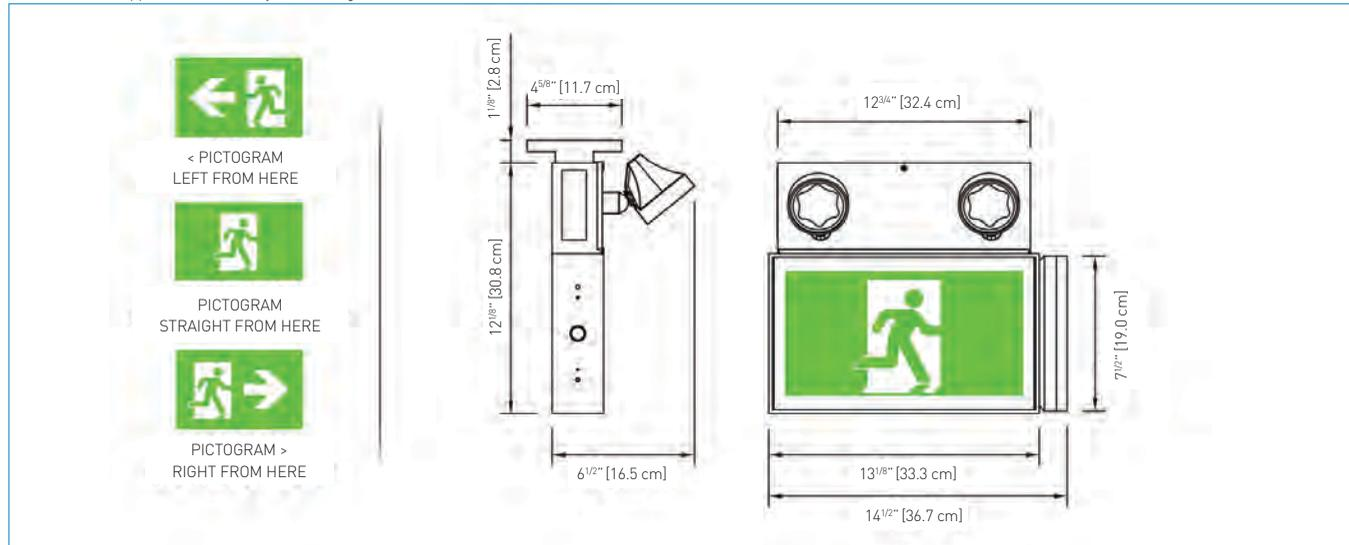

## POWER CONSUMPTION

MODEL	AC SPECS		EMERGENCY POWER AVAILABLE FOR LAMPS				
			30MIN	1H00	1H30	2H00	4H00
Pictogram Module	120/347VAC	Less than 1.5W	-	-	-	-	-
EAC-627	120/347VAC	0.15/0.05 A	27	16	11	9	-
EAC-640			40	23	16	13	-
EAC-672			72	42	30	24	12
EAC-1250	120/347VAC	0.25/0.09 A	50	29	21	16	8
EAC-1280			80	46	32	27	13

## ORDERING INFORMATION

SERIES	FACES / MOUNTING	COLOUR	POWER EM. LIGHTS	HEADS	HEAD STYLE AND WATTAGE		OPTIONS
EAC= pictogram aluminum combination unit	1= single face 2= double face universal mounting	W= factory white B= black	627= 6V-27W 640= 6V-40W 672= 6V-72W 1250= 12V-50W 1280= 12V-80W	Blank= no heads 1= one head 2= two heads	Blank= no heads LA= MR16 LED, 6V-4W LG= MR16 LED, 12V-4W LI= MR16 LED, 12V-5W LJ= MR16 LED, 12V-6W M18= mini tungsten, 12V-18W, wedge base M= mini tungsten, 12V-9W, wedge base MQ= mini halogen, 12V-8W, quartz bi-pin MQ12= mini halogen, 12V-12W, quartz bi-pin	MI= MR16 halogen, 6V-6W MJ= MR16 halogen, 6V-10W MK= MR16 halogen, 12V-12W MA= MR16 halogen, 12V-20W MB= MR16, 12V-35W MR= MR16, 12V-35W, high output	-TP= tamper-proof screws*** -2= 120/277VAC input D3= time delay [15 minutes]** U= auto-diagnostics * UN= auto-diagnostics, non-audible* NEX= NEXUS® system interface**** NEXRF= wireless NEXUS® system interface****
							*MB & MR are using EF150 type heads.
							* Not available with 6V-72W ** Time delay only with auto-diagnostics *** Bit ordered separately: 990.0119-E **** Consult your sales representative for options available with the NEXUS® system.

EXAMPLE: EAC1W6272LAD3



# LPEX50-P Series

Extruded Aluminum  
Combination Unit - 6/12V

Project/Location: \_\_\_\_\_

Contractor: \_\_\_\_\_

Date: \_\_\_\_\_

Prepared by: \_\_\_\_\_

## FEATURES

### Exit Sign

- Extruded aluminum faceplate
- Universal, field-selectable chevrons (knockout)
- **ALINGAP** LED technology

### Power Pack

- Completely self-contained unit with rechargeable sealed lead battery
- Lamp heads require no tools to adjust or aim
- Meets or exceeds CSA 22.2 No. 141 requirements



## DIMENSIONS

Dimensions are approximate and subject to change.

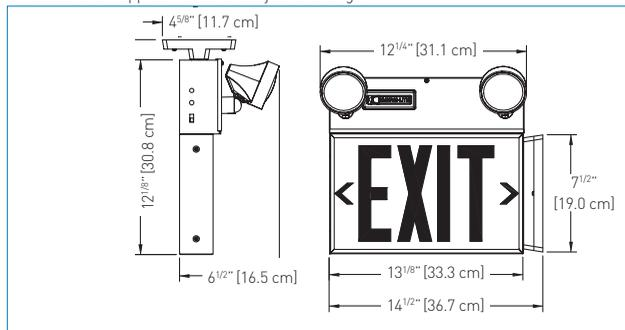

## TYPICAL SPECIFICATIONS

Supply and install the **Emergi-Lite® LPEX50-P** LED Exit Sign and power pack combination series. The exit housing shall be constructed of rugged extruded aluminum. The faceplate shall be constructed of extruded aluminum. The Exit Sign shall have a maximum depth of 2-1/2". The faceplate(s) shall come standard with knockout chevrons. The light source shall be light emitting diodes (LED). The LED lamps shall provide illumination in normal and emergency operation and shall be mounted inside the exit housing, not on the face. An LED-sensitive diffuser shall be mounted behind the legend to provide the 6" high by 3/4" stroke letters with even illumination. The power pack shall be a completely self-contained emergency unit with its own charger and rechargeable battery. The housing shall be made of steel, painted factory white. The unit shall be designed to furnish exit illumination from the normal AC source. When a power failure occurs the mounted heads along with the Exit Sign are illuminated in emergency mode for a minimum of 30 minutes. The power pack is furnished with a test switch and high charge pilot light and is available as either 18, 36 or 72W. The heads shall require no tools to adjust and aim. The heads will be constructed of a durable thermoplastic construction and use 6V, 9W lamps or as otherwise specified.

The Exit Sign shall be CSA-C860 approved and meets CSA 22.2 No. 141. The equipment shall be **Emergi-Lite®** Model: \_\_\_\_\_.

## WIRE GUARDS

460.0081-E	Wall Mount
460.0060-E	Ceiling Mount

## POWER CONSUMPTION AND UNIT RATING

MODEL	AC SPECS	WATTAGE CAPACITY					
		30MIN	1H00	1H30	2H00	4H00	
Exit Sign Module	120/347VAC	Less than 1.5W	-	-	-	-	-
LPX5-P1		0.15/0.05 A	18	10	7	6	3
LPX5-P3		0.15/0.05 A	36	21	15	12	6
LPX5-P3A		0.18/0.07 A	72	42	30	24	12
LPX5-P7		0.18/0.07 A	36	21	15	12	6
LPX5-P7A		0.15/0.05 A	72	42	30	24	12

## ORDERING INFORMATION

SERIES	COLOUR	VOLTAGE	POWERPACK	OPTIONS	NUMBER OF HEADS	HEAD STYLE AND WATTAGE
LPEX52= single face LPEX53= double face	W= factory white B= black BA= brushed aluminum* TA= textured aluminum*	Blank= 120/347VAC -2= 277VAC	-P1= 6V-18W -P3= 6V-36W -P3A= 12V-36W -P7= 6V-72W -P7A= 12V-72W	Blank= no options -G= green legend D= time delay U= auto-diagnostics X2= remote test receiver* TX2= remote test transmitter*** NEX= NEXUS® system interface** NEXRF= wireless NEXUS® system interface**	/0= no heads /1= one head /2= two heads	LA= MR16 LED, 6V-4W LG= MR16 LED, 12V-4W LI= MR16 LED, 12V-5W LJ= MR16 LED, 12V-6W M= mini tungsten, 12V-9W, wedge base MQ= mini halogen, 12V-8W, quartz bi-pin MQ12= mini halogen, 12V-12W, quartz bi-pin MI= MR16 halogen, 6V-6W MJ= MR16 halogen, 6V-10W MK= MR16 halogen, 12V-12W MA= MR16 halogen, 12V-20W Other styles available. Consult your sales representative.

EXAMPLE: LPEX52W-P3/2MQ12

Project/Location: \_\_\_\_\_

Contractor: \_\_\_\_\_

Date: \_\_\_\_\_

Prepared by: \_\_\_\_\_

# C8SR50-P Series

Extruded Aluminum  
Combination Unit - 6/12V



## FEATURES

- Rugged extruded aluminum housing with a maximum depth of 2-1/2"
- Extruded aluminum faceplate
- White finish standard
- Standard field-selectable knockout chevrons
- Long life, energy-efficient LED light source, mounted inside the exit housing, not on the faceplate.
- **ALINGAP** technology LED
- NEXUS® compatible (for more information on NEXUS®, please consult your sales representative)
- Completely self-contained unit with rechargeable sealed lead-acid battery
- Lamp heads require no tools to adjust or aim
- Provides a minimum of 30 minutes of illumination (lamp heads and exit sign) in emergency mode
- CSA certified, meets or exceeds CSA 22.2 No. 141. requirements

## DIMENSIONS

Dimensions are approximate and subject to change.

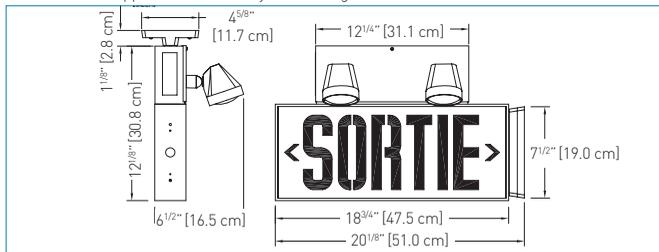

## TYPICAL SPECIFICATIONS

Supply and install the **Emergi-Lite® C8SR50-P** LED "SORTIE" Exit Sign with power pack combination series. The exit housing and the faceplate(s) shall be constructed of rugged extruded aluminum. The Exit Sign shall have a maximum depth of 2-1/2". The faceplate(s) shall come standard with knockout chevrons.

The light source shall be light emitting diodes (LED). Red LED technology shall be **ALINGAP**. The LED lamps shall provide illumination in normal and emergency operation and shall be mounted inside the exit housing, not on the face. An LED-sensitive diffuser shall be mounted behind the legend to provide the 6" high by 3/4" stroke letters with even illumination. The power pack shall be a completely self-contained emergency unit with its own charger and rechargeable battery. The housing shall be made of steel. The unit shall be designed to furnish exit illumination from the normal AC source. When a power failure occurs, the mounted heads along with the Exit Sign are illuminated in emergency mode for a minimum of 30 minutes. The power pack is furnished with a test switch and high charge pilot light and is available as either 18, 36 or 72W. The heads shall require no tools to adjust and aim. The heads will be constructed of polycarbonate and include 6V, 9W lamps or as otherwise specified.

The Exit Sign shall be CSA-C860 approved and meets CSA 22.2 No.141.

The equipment shall be **Emergi-Lite®** Model: \_\_\_\_\_.

## WIRE GUARDS

460.0081-E	Wall Mount
460.0060-E	Ceiling Mount



## POWER CONSUMPTION AND UNIT RATING

MODEL	AC SPECS	WATTAGE CAPACITY					
		30MIN	1H00	1H30	2H00	4H00	
Sortie Sign Module	120/347VAC	Less than 2W	-	-	-	-	
C8SR5= 6V-18W		0.15/0.05 A	18	10	7	6	3
C8SR5= 6V-36W		0.15/0.05 A	36	21	15	12	6
C8SR5= 12V-36W		0.18/0.07 A	72	42	30	24	12
C8SR5= 6V-72W		0.18/0.07 A	36	21	15	12	6
C8SR5= 12V-72W		0.15/0.05 A	72	42	30	24	12

## ORDERING INFORMATION

SERIES	HOUSING COLOUR	VOLTAGE	SUPPLY AND VOLTAGE	OPTIONS	#OF HEADS	MODEL AND POWER HEADLIGHTS
C8SR52= single face C8SR53= double face	W= factory white B= black BA= brushed aluminum* TA= textured aluminum*	Blank= 120/347VAC -2= 277VAC	-P1= 6V-18W -P3= 6V-36W -P3A= 12V-36W -P7= 6V-72W -P7A= 12V-72W	Blank= no options D= time delay U= auto-diagnostics X2= remote test receiver* TX2= remote test transmitter*** NEX= NEXUS® system interface** NEXRF= wireless NEXUS® system interface**  *Transmitter test required by command. ** Consult your sales representative for options *** One per order	/0= no heads /1= one head /2= two heads	LA= MR16 LED, 6V-4W LG= MR16 LED, 12V-4W LI= MR16 LED, 12V-5W LJ= MR16 LED, 12V-6W M= mini tungsten, 12V-9W, wedge base MQ= mini halogen, 12V-8W, quartz bi-pin MQ12= mini halogen, 12V-12W, quartz bi-pin MI= MR16 halogen, 6V-6W MJ= MR16 halogen, 6V-10W MK= MR16 halogen, 12V-12W MA= MR16 halogen, 12V-20W Other models available. Contact your sales representative.

EXAMPLE: C8SR52W-P1D/0M



# ES Series

All Metal Pictogram Sign

Project/Location: \_\_\_\_\_

Contractor: \_\_\_\_\_

Date: \_\_\_\_\_

Prepared by: \_\_\_\_\_

## FEATURES

- Metal construction using Canadian cold-rolled steel
- Based on a modular design, this product comes pre-assembled for quick, easy installation
- Long-life white LED light source
- Supplied standard with two pictogram films per face, for direction selection
- Meets or exceeds CSA 22.2 No.141-10 standard for pictogram exit signs
- Two-wire universal AC input: 120 to 347VAC; two-wire standard DC input: 6 to 24VDC
- Energy efficient – consumes less than 2.5W in AC mode and only 1W in DC-remote
- Self-Powered model delivers standard two hours of back-up lighting
- Universal mounting – end, wall or ceiling
- Easy access to wiring entry for all mounting options
- Canopy mounting system designed specifically for ease of installation



## DIMENSIONS

Dimensions are approximate and subject to change.

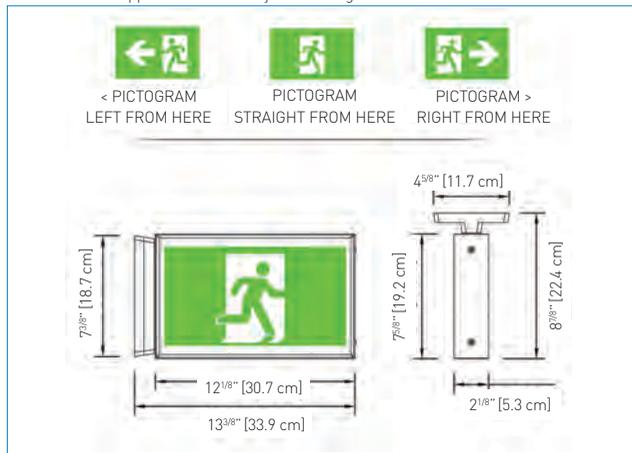

## TYPICAL SPECIFICATIONS

Supply and install the **Emergi-Lite® ES Series** pictogram Exit Signs. The equipment shall operate with universal 2-wire AC input voltage of 120 to 347VAC at less than 2.5W and universal 2-wire DC input voltage from 6 to 24VDC at 1W consumption for single and double face signs. The sign shall be suitable for wall, end, or ceiling mount. The frame and back plate shall each be of one-piece steel construction. The faceplate(s) shall be constructed of robust clear polycarbonate panels with an opaque border coloured factory-white. Each face plate shall come standard with two legend films for pictogram and directional indicators. The light source shall be white light-emitting diodes (LED) and shall provide even illumination in normal and emergency operation. The pictogram Exit Sign in a Self-Powered configuration shall use a sealed Nickel-Cadmium battery of 2.4V nominal voltage and shall stay illuminated during emergency operation for at least two hours upon AC failure.

The Exit Sign shall be listed CSA 22.2 No.141-10.

The equipment shall be **Emergi-Lite®** Model: \_\_\_\_\_.

## WIRE GUARDS

460.0079-E	Wall mount
460.0027-E	End mount
460.0028-E	Ceiling mount

## POWER CONSUMPTION

MODEL	AC SPECS		DC SPECS	
AC-only	120 to 347VAC	Less than 2.5W	-	-
AC/DC standard	120 to 347VAC	Less than 2.5W	6 to 24VDC	Less than 1W
AC/Special DC	120 to 347VAC	Less than 2.5W	36, 48, 120VDC	Less than 2.5W
Two-wire 120V AC/DC	120VAC	Less than 2.5W	120VDC	Less than 2.5W
Self-Powered	120 to 347VAC	Less than 2.5W	Nickel-Cadmium battery	Min. 2 hours

## ORDERING INFORMATION

SERIES	FACES/MOUNTING	VOLTAGE	COLOUR	OPTIONS
ES= steel pictogram Exit Sign	1= single face universal mounting 2= double face universal mounting 3= single/double face universal mounting	U= 120 to 347VAC; 6 to 24VDC I= 120 to 347VAC; Self-Powered/2 hours U00= 120 to 347VAC only U36= 120 to 347VAC; 36VDC U48= 120 to 347VAC; 48VDC U120= 120 to 347VAC; 120VDC 2120= 2-wires 120VAC/VDC	W= factory white B= black G= grey  Other colours available.	-TP= tamper-proof screws** -VRSTP= vandal-resistant shield and tamper-proof screws** 990.0119-E= tamper-proof bit*  *One bit per order. Sold separately. ** Not available on universal faces.

EXAMPLE: ES1UWVR

Project/Location:

Contractor:

Date:

Prepared by:

# EX10 Series

## All Metal Exit Sign



### FEATURES

- Two-wire universal AC input
- Pre-assembled for quick, easy installation
- Universal mounting – end, wall or ceiling
- Supplied with two stencil plates, red diffusing lenses and backplate
- Easy access to wiring entry for all mounting options
- Canopy mounting system designed specifically for ease of installation
- Universal, field-selectable chevrons (knockout)
- Energy efficient – consumes less than 3W in AC or DC mode
- Normal AC and emergency DC operation – 120 to 347V AC input; 6 to 24V DC input
- Long life energy-efficient **ALINGAP** technology LED light source
- Also available with power pack; see EX10-P catalogue sheet
- CSA certified, meets or exceeds CSA 22.2 No. 141. requirements

### TYPICAL SPECIFICATIONS

Supply and install the **Emergi-Lite® EX10 Series** Exit Signs. The equipment shall operate with universal 2-wire AC input voltage of 120 to 347VAC at less than 1.5W and universal 2-wire DC input voltage from 6 to 24VDC at less than 1.5W for single and double face signs. The sign shall be suitable for wall, end, or ceiling mount. The faceplates shall be constructed of steel and shall come standard with knockout chevrons. The frame shall be of one-piece steel construction.

The light source shall be light-emitting diodes (LED). The LED lamps shall provide illumination in normal and emergency operation and shall be mounted inside the exit housing, not on the face. Red LEDs shall be of **ALINGAP** technology.

An LED-sensitive diffuser shall be mounted behind the legend to provide the 6" high by 3/4" stroke letters with even illumination.

The Exit Sign in a Self-Powered configuration shall stay illuminated during emergency operation for at least 90 minutes upon AC failure.

The Exit Sign shall be CSA-C860 approved and meets CSA 22.2 No.141.

The equipment shall be **Emergi-Lite®** Model: \_\_\_\_\_

### DIMENSIONS

Dimensions are approximate and subject to change.

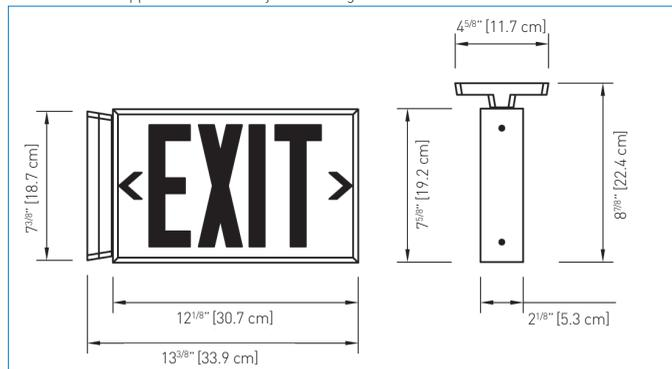

### POWER CONSUMPTION

MODEL	AC SPECS	DC SPECS		
AC-only, red	120 to 347VAC Less than 1.5W	-	-	-
AC/DC standard, red	120 to 347VAC Less than 1.5W	6 to 24VDC	Less than 1.5W	Less than 1.5W
AC/special DC, red	120/277/ 347VAC Less than 3W	36 or 48 or 120VDC	Less than 2.5W	Less than 2.5W
Self-Powered red	120 to 347VAC Less than 3W	Nickel-Cadmium battery	Min. 60 minutes	Min. 60 minutes
AC-only, green	120 to 347VAC Less than 1.5W	-	-	-
AC/DC standard, green	120 to 347VAC Less than 1.5W	6 to 24VDC	Less than 2.5W	Less than 2.5W
Self-Powered green	120 to 347VAC Less than 3W	Nickel-Cadmium battery	Min. 90 minutes	Min. 90 minutes

### WIRE GUARDS

460.0079-E	Wall Mount
460.0027-E	End Mount
460.0028-E	Ceiling Mount

### ORDERING INFORMATION

SERIES	COLOUR	POWER SOURCE AND VOLTAGE	OPTIONS
<b>EX10=</b> LED EXIT sign / Universal mount	<b>W=</b> factory white <b>B=</b> black <b>TA=</b> textured aluminum  Other colours available, please contact your sales representative.	<b>-U=</b> universal voltage 120 to 347VAC 6 to 24VDC <b>-U00=</b> 120 to 347VAC, no DC** <b>-U36=</b> 120/277/347VAC - 36VDC* <b>-U48=</b> 120/277/347VAC, 48VDC* <b>-U120=</b> 120/347VAC, 120VDC* <b>-EM120-2W=</b> 120VAC, 120VDC 2 wires* <b>-I=</b> Self-Powered 120 to 347VAC  *For green legend, consult your sales representative. ** Supply as single face	<b>-TP=</b> tamper-proof screws <b>-VRTP=</b> vandal resistant shield with tamper-proof screws** <b>-G=</b> green legend <b>990.0119-E=</b> tamper-proof bit*  *One bit per order. **Indicate single or double face

EXAMPLE: EX10W-U



# C8SR10 Series

All Metal "Sortie" Sign

Project/Location:	_____
Contractor:	_____
Date:	_____
Prepared by:	_____

## FEATURES

- Metal construction using Canadian cold-rolled steel with baked enamel finish – will not yellow
- Metal legend panel with red letter panel
- Universal mounting – end, wall or ceiling
- Easy access to wiring entry for all mounting options
- Canopy mounting system designed specifically for ease of installation
- Standard field-selectable directional knockout chevrons
- Long life, energy efficient **ALINGAP** technology light source
- Energy efficient – consumes less than 3W
- Normal AC and emergency DC operation – 120V to 347VAC and 6V to 24VDC input
- CSA certified, meets or exceeds CSA 22.2 No. 141. requirements
- Metal construction using Canadian cold-rolled steel
- Long-life, energy-efficient **ALINGAP** technology LED light source completely enclosed in acrylic module
- Also available with power pack; see SR catalogue sheet

## DIMENSIONS

Dimensions are approximate and subject to change.



## TYPICAL SPECIFICATIONS

Supply and install the **Emergi-Lite® C8SR10 Series** LED "SORTIE" Exit Signs. The equipment shall operate with universal two-wire AC input voltage of 120VAC to 347VAC at less than 1.5W and universal two-wire DC input voltage from 6VDC to 24VDC at less than 1.5W for single or double face signs.

The sign shall be suitable for wall, end or ceiling mount. The faceplates shall be constructed of steel and shall come standard with knockout chevrons. The frame shall be of a one-piece steel construction.

The light source shall be light emitting diodes (LED). The LED lamps shall provide illumination in normal and emergency operation and shall be mounted inside the exit housing, not on the face.

Red LED technology shall be **ALINGAP**. An LED-sensitive diffuser shall be mounted behind the legend to provide the 6" high by 3/4" stroke letters with even illumination.

The Exit Sign in a Self-Powered configuration shall stay illuminated during emergency operation for at least 60 minutes upon AC failure.

The Exit Sign shall be CSA-C860 approved and meets CSA 22.2 No. 141.

The equipment shall be **Emergi-Lite®** Model: \_\_\_\_\_ .

## WIRE GUARDS

460.0057-E	Wall Mount
460.0048-E	End Mount
460.0058-E	Ceiling Mount



## POWER CONSUMPTION AND UNIT RATING

MODEL	AC SPECS		DC SPECS	
	AC/DC standard, red	120 to 347VAC	Less than 1.5W	6 to 24VDC
AC/special DC, red	120/277/347VAC	Less than 2.5W	36 or 48 or 120VDC	Less than 2.5W
Self-Powered red	120 to 347VAC	Less than 3W	Nickel-Cadmium battery	Minimum 60 minutes

## ORDERING INFORMATION

SERIES	COLOUR	SUPPLY AND VOLTAGE	OPTIONS
<b>C8SR10</b> = universal mounting LED SORTIE	<b>W</b> = factory white <b>B</b> = black <b>TG</b> = textured grey  Other colours available. Consult your sales representative.	<b>-U</b> = 120/347VAC, 6/12/24VDC <b>-I</b> = Self-Powered 120/347VAC <b>-EM120-2W</b> = 120VAC, 120VDC 2 wires <b>-U36</b> = 120/277/347VAC, 36VDC <b>-U48</b> = 120/277/347VAC, 48VDC <b>-U120</b> = 120/347VAC, 120VDC	<b>-TP</b> = tamper-proof screws <b>-VRTP</b> = vandal resistant shield with tamper-proof screws** <b>990.0119-E</b> = tamper-proof bit*  *One bit needed per order. ** Indicate single or double face

EXAMPLE: C8SR10W-U-TP

Project/Location:

Contractor:

Date:

Prepared by:

# C8ES10 & C8SE10 Series

Bilingual Steel Sign



## FEATURES

- Single illumination module lights both single and double face Exit Signs
- Highly energy efficient – consumes a maximum of 5.5W in AC or DC mode
- Normal AC and emergency DC operation – 120 to 347V AC input; 6 to 24V DC input
- Meets or exceeds CSA 22.2 No. 141 requirements.

## DIMENSIONS

Dimensions are approximate and subject to change.

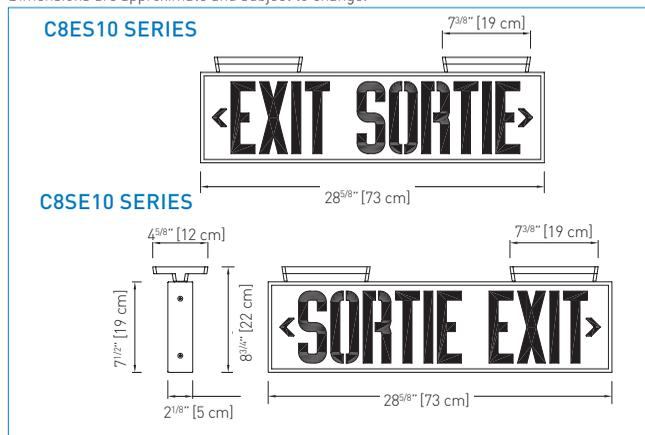

## TYPICAL SPECIFICATIONS

Supply and install the **Emergi-Lite®** bilingual **C8ES10 or C8SE10 Series** LED Exit Sign. The equipment shall operate with universal AC input voltage of 120 to 347VAC at less than 3W and universal two-wire DC input voltage from 6VDC to 24VDC at less than 3.5W for single and double face signs. The frame shall be of one-piece steel construction and have a maximum depth of 2-1/8". The faceplate(s) shall be steel and come standard with knockout chevrons. The equipment shall have two (2) canopies that shall fasten for installation in ceiling-mount applications. The light source shall be light emitting diodes (LED). The LED lamps shall provide illumination in normal and emergency operation and shall be mounted inside the exit housing, not on the face. Red LED technology shall be **ALINGAP**. An LED-sensitive diffuser shall be mounted behind the legend to provide the 6" high by 3/4" stroke letters with even illumination.

The Exit Sign in a Self-Powered configuration shall stay illuminated during emergency operation for at least \_\_\_\_\_ minutes upon AC failure.

The Exit Sign shall be CSA-C860 approved and meets CSA 22.2 No.141. The equipment shall be **Emergi-Lite®** Model: \_\_\_\_\_.

## WIRE GUARDS

460.0059-E	Wall Mount
460.0092-E	Ceiling Mount



## POWER CONSUMPTION AND UNIT RATING

MODEL	AC SPECS		DC SPECS	
AC/DC standard, red	120 to 347VAC	Less than 3W	6 to 24VDC	Less than 3.5W
AC/special DC, red	120/277/347VAC	Less than 5W	36 or 48 or 120VDC	Less than 5W
Self-Powered red	120 to 347VAC	Less than 6W	Nickel-Cadmium Battery	Min. 60 or 120 minutes

## ORDERING INFORMATION

SERIES	LETTERING	FACES	COLOUR	POWER SOURCE AND VOLTAGE	OPTIONS
C8= LED C860 approved	ES= EXIT SORTIE 6" letters SE= SORTIE EXIT 6" letters	12= single face 13= double face	W= factory white B= black TG= textured grey	-U= 120 to 347VAC, 6 to 24 VDC -EM120-2M=120VAC, 120VDC, 2 wires -U36= 120/277/347VAC - 36VDC -U48= 120/277/347VAC - 48VDC -U120= 120/277/347VAC - 120VDC -I= 120 to 347VAC, Self-Powered, (60 minutes) -I2= 120 to 347VAC Self-Powered, (120 minutes)	Blank= 2 canopies supplied -TP= tamper-proof screws -VRTP= vandal resistant shield with tamper-proof screws** -3C= 3 canopies 990.0119-E= tamper-proof bit*  *One bit needed per order. ** Indicate single or double face

EXAMPLE: C8ES12W-U-VRTP



# ESC Series

Steel Combination Unit

Project/Location: \_\_\_\_\_

Contractor: \_\_\_\_\_

Date: \_\_\_\_\_

Prepared by: \_\_\_\_\_

## FEATURES

- Universal mounting: end, wall or ceiling
- Meets or exceeds CSA 22.2 No.141-10 standard for unit equipment and pictogram Exit Signs
- Legend illuminated by long-life white LED's
- Comes standard with two pictogram films, for direction selection
- Sealed, maintenance-free, 6V or 12V Lead-Calcium battery
- Remote load capacity: 80W up to 560' of egress illumination when using LED remote heads

## DIMENSIONS

Dimensions are approximate and subject to change.

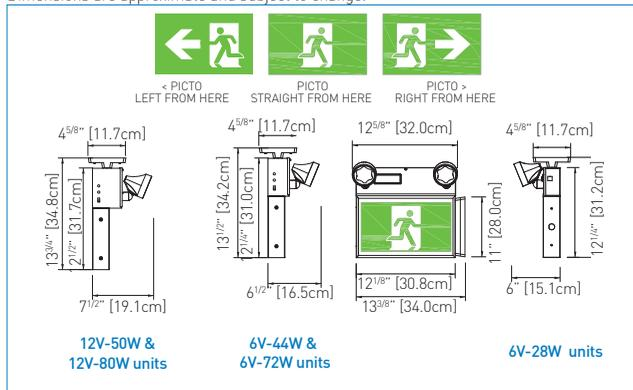

## TYPICAL SPECIFICATION

Supply and install **Emergi-Lite® ESC Series** combination emergency light battery unit and pictogram Exit Sign. The unit shall be made of solid steel sheet metal and be suitable for universal mounting: wall, end, or ceiling. The legend housing shall have a maximum depth of 2-1/8". The legend face plate(s) shall be constructed of robust clear polycarbonate panel(s) with an opaque border coloured factory-white. Each face plate shall come standard with two legend films for pictogram and direction selection. The light source shall be white light-emitting diodes (LED) and shall provide even illumination in normal and emergency operation. The power pack shall include one circuit board with test switch and pilot light for battery charger and legend LED driver. The unit shall include one 6V or 12V, maintenance-free, sealed Lead-Calcium battery and shall provide minimum 30 minutes of emergency lighting upon AC power failure. The electrical power available for emergency lights shall be 28W or up to 72W, for 6V and 50W or up to 80W for 12V, as specified. The emergency heads shall require no tools to adjust and aim. The equipment shall meet or exceed the requirements of CSA 22.2 No.141-10 standard.

The equipment shall be **Emergi-Lite®** Model: \_\_\_\_\_

## WIRE GUARDS

460.0081-E	Wall mount
460.0060-E	Ceiling mount



## POWER CONSUMPTION

MODEL	AC SPECS	EMERGENCY POWER AVAILABLE FOR LAMPS					
		30MIN	1H00	1H30	2H00	4H00	
Pictogram Module	120/347VAC	Less than 1.5W	-	-	-	-	-
ESC28		0.13 / 0.05 A	28	16	12	9	-
ESC44		0.13 / 0.05 A	44	26	18	15	7
ESC72		0.13 / 0.05 A	72	42	30	24	12
ESC-1250		0.25 / 0.09 A	50	29	21	16	8
ESC-1280		0.25 / 0.09 A	80	46	32	27	13

## ORDERING INFORMATION

SERIES	POWER EM. LIGHTS	HOUSING COLOUR	HEADS	HEAD STYLE AND WATTAGE	OPTIONS
ESC= pictogram steel combo exit sign	28= 6V-28W 44= 6V-44W 72= 6V-72W* 1250= 12V-50W* 1280= 12V-80W*	W= factory white B= black	Blank= no heads 1= one head 2= two heads	Blank= no heads LA= MR16 LED, 6V-4W LG= MR16 LED, 12V-4W LI= MR16 LED, 12V-5W LJ= MR16 LED, 12V-6W M= mini tungsten, 12V-9W, wedge base MQ= mini halogen, 12V-8W, quartz bi-pin MQ12= mini halogen, 12V-12W, quartz bi-pin MI= MR16 halogen, 6V-6W MJ= MR 16 halogen, 6V-10W MK= MR16 halogen, 12V-12W MA= MR16 halogen, 12V-20W MB= MR16 halogen, 12V-35W* MR= MR16 high-output, 12V-35W*	-TP= tamper-proof screws* -2= 120/277VAC input DF= double face sign D3= time delay (15 minutes) NEX= NEXUS® system interface** NEXRF= wireless NEXUS® system interface** U= auto-diagnostics*** UN= auto-diagnostics, non audible***  * Bit ordered separately: 990.0119-E ** Max. 44W; consult your sales representative *** U & UN available for 12V units only
	*Not available with NEX & NEXRF			*MB & MR are using EL150 type heads	

EXAMPLE: ESC28W2LA

Project/Location: \_\_\_\_\_

Contractor: \_\_\_\_\_

Date: \_\_\_\_\_

Prepared by: \_\_\_\_\_

# EX10-P & LPEX10-P Series

Metal Combination Unit



## FEATURES

- Dual input voltages 120/347VAC
- Comes pre-assembled for quick, easy installation
- Universal mounting – end, wall or ceiling
- Easy access to wiring entry for all mounting options
- Canopy mounting system designed specifically for ease of installation
- Universal fields-selectable chevrons (knock out)
- Energy efficient – complete unit consumes less than 5W
- CSA certified, meets or exceeds CSA 22.2 No. 141 requirements
- Long life, energy-efficient LED light source, mounted inside the exit housing, not on the faceplate

## DIMENSIONS

Dimensions are approximate and subject to change.

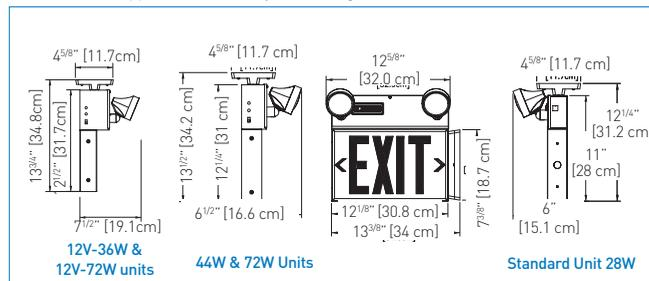

## TYPICAL SPECIFICATIONS

Supply and install the **Emergi-Lite® EX10-P & LPEX10-P Series** LED Exit Sign and power pack combination series. The exit housing and faceplates shall be constructed of steel. The Exit Sign shall have a maximum depth of 2-1/2". The faceplate(s) shall come standard with knockout chevrons. The light source for the Exit Sign shall be light-emitting diodes (LED). The LED lamps shall provide illumination in normal and emergency operation and shall be mounted inside the exit housing, not on the face. Red LEDs shall be of **ALINGAP** technology. An LED sensitive diffuser shall be mounted behind the legend to provide the 6" high by 3/4" stroke letters with even illumination. The power pack shall be a completely self-contained emergency unit with its own charger and rechargeable battery. The housing shall be made of steel. The power pack shall include a test switch and high charge pilot light. The equipment shall be designed to furnish exit illumination from the normal AC source. When a power failure occurs the Exit Sign along with the emergency heads shall illuminate for a minimum of 30 minutes. The power available for emergency lights shall be 28W or as otherwise specified. The heads shall require no tools to adjust and aim. The heads will be of a durable thermoplastic construction and use 6V, 9W and 12V, 9W lamps or as otherwise specified. The Exit Sign shall be CSA-C860 approved and meets CSA 22.2 No. 141. The equipment shall be **Emergi-Lite®** Model: \_\_\_\_\_.

## EXTRA FACEPLATES

005406-E	Factory white faceplate + red diffuser	005409-E	Factory white faceplate + green diffuser
005407-E	Black faceplate + red diffuser	005410-E	Black faceplate + green diffuser
005408-E	Silver grey faceplate + red diffuser	005411-E	Silver grey faceplate + green diffuser

## WIRE GUARDS

460.0060-E	Ceiling Mount
460.0081-E	Wall Mount

## POWER CONSUMPTION AND UNIT RATING

MODEL	AC SPECS	WATTAGE CAPACITY					
		30MIN	1H00	1H30	2H00	4H00	
Exit Sign Module	120/347VAC	Less than 1.5W	-	-	-	-	
EX10-P		0.15/0.05 A	28	16	12	9	-
EX10-P4		0.15/0.05 A	44	26	18	15	7
EX10-P7		0.15/0.05 A	72	42	30	24	12
LPEX10-P3A		less than 5W	76	21	15	12	6
LPEX10-P7A		less than 5W	72	42	30	24	12

## ORDERING INFORMATION

SERIES	COLOUR	VOLTAGE	POWERPACK	OPTIONS	# OF HEADS	HEAD STYLE AND WATTAGE
EX10=6V	W= factory white B= black G= grey*	Blank= 120/347VAC -2= 120/277VAC	-P= 6V-28W -P4= 6V-44W -P7= 6V-72W P3A = 12V-36W P7A = 12V-72W	Blank= no options -TP= tamper-proof screws -G= green legend D= time delay U= auto-diagnostic, audible*** UN= auto-diagnostic, non-audible*** 990.0119-E= tamper-proof bit* NEX= NEXUS® system interface** NEXRF= wireless NEXUS® system interface** * One bit per order. **Consult your sales representative for options available with the NEXUS® system. ***Only available in 12V units.	/0= no head /1= one head /2= two heads	LA= MR16 LED, 6V-4W LG= MR16 LED, 12V-4W LI= MR16 LED, 12V-5W LJ= MR16 LED, 12V-6W M= mini tungsten, 12V-9W, wedge base MQ= mini halogen, 12V-8W, quartz bi-pin MQ12= mini halogen, 12V-12W, quartz bi-pin MI= MR16 halogen, 6V-6W MJ= MR16 halogen, 6V-10W MK= MR16 halogen, 12V-12W MA= MR16 halogen, 12V-20W Other styles available. Consult your sales representative
LPEX10=12V	*Black heads					

EXAMPLE: EX10W-P3/2MQ12



# SR Series

All Metal "Sortie" Combination Unit

Project/Location:	_____
Contractor:	_____
Date:	_____
Prepared by:	_____

## FEATURES

- Pre-assembled for ease of installation
- Metal housing with baked enamel finish – will not yellow
- Easy access to wiring entry
- Exit Sign with long life, **ALINGAP** LED light source
- Energy efficient, consumes less than 3W in stand-by mode
- Power pack comes standard with premium Lead-Calcium battery
- Other colours and options are available upon request
- CSA certified, meets or exceeds CSA 22.2 No. 141 requirements



## TYPICAL SPECIFICATIONS

Supply and install the **Emergi-Lite® SR Series** LED "SORTIE" Exit Sign with power pack series. The exit housing and the faceplate(s) shall be constructed of steel. The Exit Sign shall have a maximum depth of 2-1/2". The faceplate(s) shall come standard with knockout chevrons.

The light source shall be light emitting diodes (LED). Red LED technology shall be **ALINGAP**. The LED lamps shall provide illumination in normal and emergency operation and shall be mounted inside the exit housing, not on the face. An LED-sensitive diffuser shall be mounted behind the legend to provide the 6" high by 3/4" stroke letters with even illumination.

The power pack shall be a completely self-contained emergency unit with its own charger and rechargeable battery. The housing shall be made of steel. The unit shall be designed to furnish exit illumination from the normal AC source. When a power failure occurs, the mounted heads along with the Exit Sign are illuminated in emergency mode for a minimum of 30 minutes. The power pack shall be furnished with a test switch and high charge pilot light.

The heads shall require no tools to adjust and aim. The heads will be constructed of durable thermoplastic and use 6V, 9W lamps or as otherwise specified.

The Exit Sign shall be CSA-C860 approved and meets CSA 22.2 No.141.

The equipment shall be **Emergi-Lite®** Model: \_\_\_\_\_

## WIRE GUARDS

460.0078-E	Wall Mount
460.0060-E	Ceiling Mount

Project/Location:

Contractor:

Date:

Prepared by:

# SR Series

All Metal "Sortie" Combination Unit



## DIMENSIONS

Dimensions are approximate and subject to change.

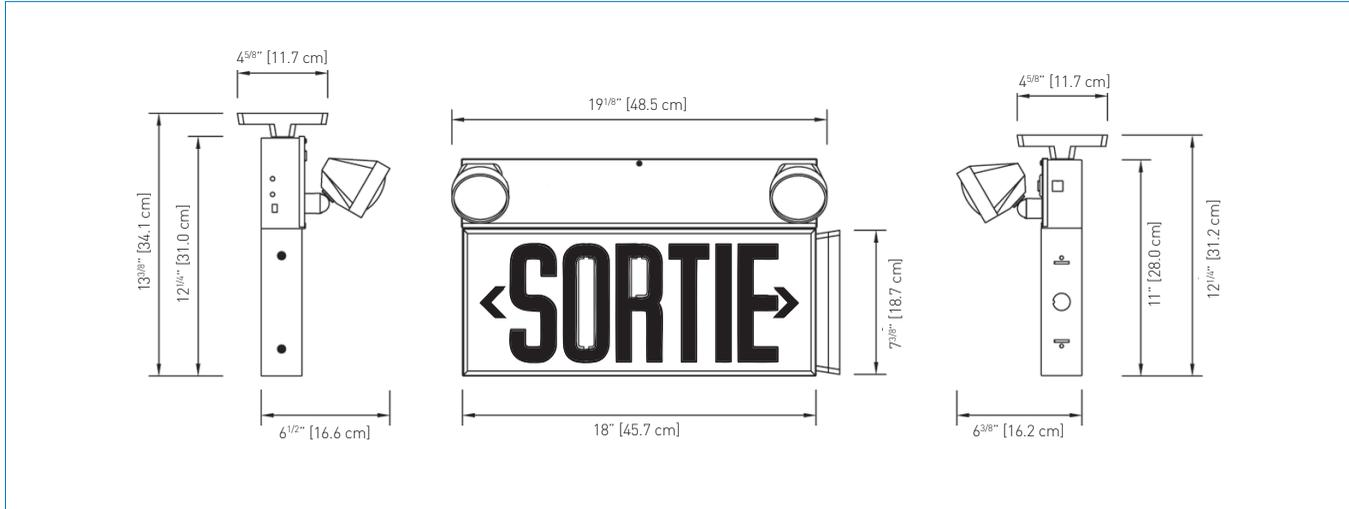

## POWER CONSUMPTION AND UNIT RATING

MODEL	AC SPECS		WATTAGE CAPACITY				
			30MIN	1H00	1H30	2H00	4H00
Sortie Sign Module	120/347VAC	Less than 2W	-	-	-	-	-
R27= 6V-27W		0.25/0.08 A	27	15	12	9	-
R50= 6V-50W		0.25/0.08 A	50	30	20	16	8
12R50= 12V-50W		0.25/0.08 A	50	30	20	16	8
12R80= 12V-80W		0.25/0.08 A	80	45	36	27	12

## ORDERING INFORMATION

SERIES	COLOUR	VOLTAGE	VOLTAGE AND SUPPLY	OPTIONS	# OF HEADS	MODEL AND POWER HEADLIGHTS
<b>SR12</b> = single face, wall or ceiling mount <b>SR10</b> = universal steel mount canopy with two faceplates	<b>W</b> = factory white <b>B</b> = black <b>TG</b> = textured grey*	<b>Blank</b> = 120/347VAC	<b>-P</b> = 6V-27W <b>-P5</b> = 6V-50W <b>-P5A</b> = 12V-50W <b>-P8A</b> = 12V-80W	<b>Blank</b> = no options <b>-TP</b> = tamper-proof screws <b>D1</b> = time delay (5 minutes) <b>D2</b> = time delay (10 minutes) <b>D3</b> = time delay (15 minutes) <b>990.0119-E</b> = tamper-proof bit*	<b>/0</b> = no heads <b>/1</b> = one head <b>/2</b> = two heads	<b>LA</b> = MR16 LED, 6V-4W <b>LG</b> = MR16 LED, 12V-4W <b>LI</b> = MR16 LED, 12V-5W <b>LJ</b> = MR16 LED, 12V-6W <b>M</b> = mini tungsten, 12V-9W, wedge base <b>MQ</b> = mini halogen, 12V-8W, quartz bi-pin <b>MQ12</b> = mini halogen, 12V-12W, quartz bi-pin <b>MI</b> = MR16 halogen, 6V-6W <b>MJ</b> = MR16 halogen, 6V-10W <b>MK</b> = MR16 halogen, 12V-12W <b>MA</b> = MR16 halogen, 12V-20W
	* Black heads			*One bit per proof		Other models available. Consult your sales representative.

EXAMPLE: SR12W-P/0M



# 12ESL-EX Series

High Capacity Combination Unit

Project/Location: \_\_\_\_\_

Contractor: \_\_\_\_\_

Date: \_\_\_\_\_

Prepared by: \_\_\_\_\_

## FEATURES

- Standard 120/347VAC input
- Wide range of lamp heads available
- Solid-state pulse-type charger standard
- Sealed dust-proof transfer relay
- Auto-diagnostic charger available (110W only)
- Meets or exceeds CSA 22.2 No. 141.



## DIMENSIONS

Dimensions are approximate and subject to change.

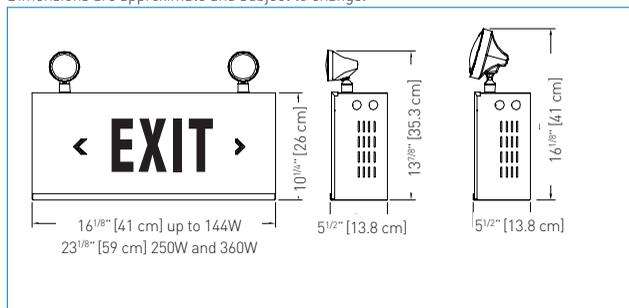

## TYPICAL SPECIFICATIONS

Supply and install the **Emergi-Lite® 12ESL-EX Series** "Exit" a unit that combines an illuminated LED Exit Sign with an emergency light battery unit. The housing and faceplate shall be constructed of steel. The faceplate shall come standard with knockout chevrons. The light source for the Exit Sign shall be LED. The LED lamps shall provide illumination in normal and emergency operation. Red LEDs shall be of **ALINGAP** technology. The charger board, the battery and the LEDs shall be contained in a single housing. A diffuser optimized for LEDs shall be mounted behind the legend to provide the 6" high by 3/4" stroke letters with even illumination. The unit shall include a test switch and high charge pilot light. The equipment shall be designed to furnish exit illumination from the normal AC source. When a power failure occurs, the Exit Sign along with the emergency heads shall illuminate for a minimum of 30 minutes. The power available for emergency lights shall be at least 110W or as otherwise specified. The heads shall require no tools to aim and shall be as specified. The Exit Sign shall be CSA-C860 approved and meets CSA 22.2 No. 141. The equipment shall be **Emergi-Lite®** Model: \_\_\_\_\_.

## WIRE GUARDS

460.0081-E	Wall Mount 110W and 144W
460.0034-E	Wall Mount 250W and 360W

\*Housing width is 23 1/8" for 250W and 360W capacity only (cabinet C). For more information please consult your sales representative

## POWER CONSUMPTION AND UNIT RATING

MODEL	AC SPECS	WATTAGE CAPACITY					
		30MIN	1H00	1H30	2H00	4H00	
Exit Sign Module	120/347VAC	Less than 2W	-	-	-	-	-
12ESL110		0.25/0.10 A	110	64	45	36	18
12ESL144		0.25/0.10 A	144	84	60	48	24
12ESL250		0.45/0.15 A	250	144	100	83	42
12ESL360		0.45/0.15 A	360	210	150	120	60

## ORDERING INFORMATION

SERIES, VOLTAGE AND WATTAGE	COLOUR	LETTERING	VOLTAGE	OPTIONS	# OF HEADS	HEADS STYLE AND WATTAGE
12ESL110= 12V - 110W 12ESL144= 12V - 144W 12ESL250= 12V - 250W 12ESL360= 12V - 360W	Blank= factory white B= black	EX= EXIT	Blank= 120/347VAC 2= 277VAC	Blank= no options U= auto-diagnostics (110W only)	/0= no heads /1= one head /2= two heads /3= three heads	Blank= large tungsten, 12V-9W, wedge base -18= large tungsten, 12V-18W, wedge base -25= large tungsten, 12V-25W, DCB 150MK= MR16 Deco head EF150, 12V-12W 150MA= MR16 Deco head EF150, 12V-20W 150MB= MR16 Deco head EF150, 12V-35W 150MC= MR16 Deco head EF150, 12V-50W LG= MR16 LED, 12V-4W LI= MR16 LED, 12V-5W LJ= MR16 LED, 12V-6W H= large halogen, 12V-8W, quartz sealed beam H12= large halogen, 12V-12W, quartz sealed beam M= mini tungsten, 12V-9W, wedge base M18= mini tungsten, 12V-18W, wedge base MQ= mini halogen, 12V-8W, quartz bi-pin MQ12= mini halogen, 12V-12W, quartz bi-pin MK= MR16 halogen, 12V-12W MA= MR16 halogen, 12V-20W Q= large halogen, 12V-8W, quartz bi-pin Q12= large halogen, 12V-12W, quartz bi-pin Q20= large halogen, 12V-20W, quartz bi-pin Q55= large halogen, 12V-55W, quartz bi-pin S12= large tungsten, 12V-12W, sealed beam S18= large tungsten, 12V-18W, sealed beam S25= large tungsten, 12V-25W, sealed beam

EXAMPLE: 12ESL110EX/2M

Project/Location:

Contractor:

Date:

Prepared by:

# 12ESL-SR Series

## High Capacity Combination Unit



### FEATURES

- Standard 120/347VAC input
- Selection of lamp head styles
- Solid state pulse type charger standard
- Sealed dust-proof transfer relay
- Optional self-diagnostic charger (110W only)
- Available in 12V, 110, 144, 250 and 360W
- Long life, maintenance free lead acid battery
- Fully C860 approved "SORTIE" legend illuminated with ALINGAP LEDs and meets or exceeds CSA 22.2 No. 141.
- High-quality steel enclosure with corrosion-resistant undercoating



### DIMENSIONS

Dimensions are approximate and subject to change.

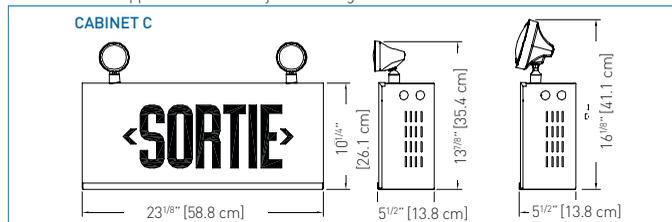

### TYPICAL SPECIFICATIONS

Supply and install the **Emergi-Lite® 12ESL-SR Series** LED "SORTIE" combo unit. The housing and faceplate shall be constructed of steel. The faceplate shall come standard with knockout chevrons.

The light source shall be light emitting diodes (LED). The LED lamps shall provide illumination in normal and emergency operation. Red LED technology shall be **ALINGAP**. The power pack, rechargeable battery and LEDs shall be contained in a single housing. A diffuser optimized for LEDs shall be mounted behind the legend to provide the 6" high by 3/4" stroke letters with even illumination. The power pack is furnished with a test switch and high charge pilot light. The unit shall be designed to provide Exit Sign illumination from the normal AC source. When a power failure occurs, the mounted heads along with the Exit Sign are illuminated in emergency mode for a minimum of 30 minutes. The power available for emergency lights shall be 110W or as otherwise specified. The heads shall require no tools to adjust and aim. The heads will be constructed of durable thermoplastic and use 6V, 9W lamps or as otherwise specified. The Exit Sign shall be CSA-C860 approved and meets CSA 22.2 No. 141. The equipment shall be **Emergi-Lite®** Model: \_\_\_\_\_

### WIRE GUARDS

460.0034-E	Wall Mount
------------	------------

### POWER CONSUMPTION AND UNIT RATING

MODEL	AC SPECS	WATTAGE CAPACITY					
		30MIN	1H00	1H30	2H00	4H00	
Sortie Sign Module	120/347VAC	Less than 2W	-	-	-	-	
12ESL110		0.25/0.10 A	110	64	45	36	18
12ESL144		0.25/0.10 A	144	84	60	48	24
12ESL250		0.45/0.15 A	250	144	100	83	42
12ESL360		0.45/0.15 A	360	210	150	120	60

### ORDERING INFORMATION

SERIES, VOLTAGE AND WATTAGE	COLOUR	LETTERING	VOLTAGE	OPTIONS	# OF HEADS	HEADS STYLE AND WATTAGE
12ESL110= 12V - 110W 12ESL144= 12V - 144W 12ESL250= 12V - 250W 12ESL360= 12V - 360W	Blank= factory white B= black	SR= SORTIE	Blank= 120/347VAC 2= 277VAC	Blank= no options U= auto-diagnostics (110W only)	/0= no heads /1= one head /2= two heads /3= three heads	Blank= large tungsten, 12V-9W, wedge base -18= large tungsten, 12V-18W, wedge base -25= large tungsten, 12V-25W, DCB 150MK= MR16 Deco head EF150, 12V-12W 150MA= MR16 Deco head EF150, 12V-20W 150MB= MR16 Deco head EF150, 12V-35W 150MC= MR16 Deco head EF150, 12V-50W LG= MR16 LED, 12V-4W LI= MR16 LED, 12V-5W LJ= MR16 LED, 12V-6W H= large halogen, 12V-8W, quartz sealed beam H12= large halogen, 12V-12W, quartz sealed beam M= mini tungsten, 12V-9W, wedge base M18= mini tungsten, 12V-18W, wedge base MQ= mini halogen, 12V-8W, quartz bi-pin MQ12= mini halogen, 12V-12W, quartz bi-pin MK= MR16 halogen, 12V-12W MA= MR16 halogen, 12V-20W Q= large halogen, 12V-8W, quartz bi-pin Q12= large halogen, 12V-12W, quartz bi-pin Q20= large halogen, 12V-20W, quartz bi-pin Q55= large halogen, 12V-55W, quartz bi-pin S12= large tungsten, 12V-12W, sealed beam S18= large tungsten, 12V-18W, sealed beam S25= large tungsten, 12V-25W, sealed beam Note: Other styles available. Consult your sales representative.

EXAMPLE: 12ESL110EX/0M



# EP Series

All-Plastic Pictogram Exit Sign  
Commercial-grade, universal-mount  
and snap-fit

Project/Location:
Contractor:
Date:
Prepared by:

## FEATURES

The **Emergi-Lite® EP Series** is a compact pictogram Exit Sign with an all-in-one, snap-fit design. Easy to install and affordable, the **EP Series** Exit Sign is ideally suited for commercial applications, especially those in which large numbers of Exit Signs are required.

- Durable, factory white, thermoplastic housing
- Universal mounting: wall-, end-, or ceiling-mount
- Long-life white LED light source
- Supplied standard with two pictogram films per face, for direction selection
- Certified CSA 22.2 No.141-10 for pictogram safety signs
- Two-wire universal AC input: 120 to 347VAC; two-wire standard DC input: 6 to 24VDC
- Energy efficient – consumes less than 2.5W in AC mode and only 1W in DC-remote
- Self-Powered model delivers standard two hours of back-up lighting
- Optional vandal-proof shield and tamper-proof screws

## DIMENSIONS

Dimensions are approximate and subject to change.

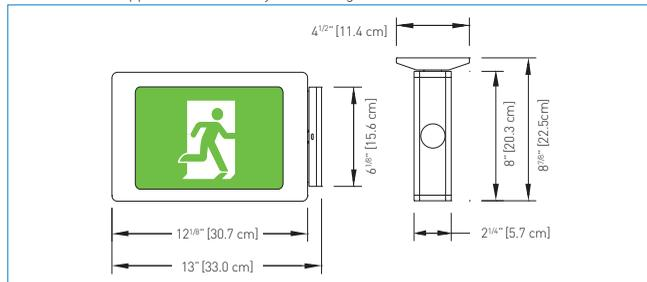

## TYPICAL SPECIFICATIONS

Supply and install the **Emergi-Lite® EP** pictogram Exit Sign. The equipment shall operate with universal 2-wire AC input voltage of 120 to 347VAC at less than 2.5W and universal 2-wire DC input voltage from 6 to 24VDC at 1W consumption for single and double face signs. The sign shall come standard with a canopy and shall be suitable for wall, end, or ceiling mounting. The frame, faceplates, back plate and canopy shall each be constructed of a one-piece UV-stabilized thermoplastic material colored factory white. Each faceplate shall come standard with two legend films for pictogram and directional indicators. The light source shall be white light-emitting diodes (LED) and shall provide even illumination in normal and emergency operation. The equipment in a Self-Powered configuration shall use a sealed Nickel-Cadmium battery of 2.4V nominal voltage. The equipment shall recharge the battery in 24 hours and stay illuminated at least two hours upon AC failure.

The pictogram Exit Sign shall be listed to the CSA 22.2 No.141-10 standard.

The equipment shall be **Emergi-Lite®** Model: \_\_\_\_\_.



## POWER CONSUMPTION AND UNIT RATING

MODEL	AC SPECS		DC SPECS	
AC only	120 to 347VAC	Less than 2.5W	-	-
AC/DC standard	120 to 347VAC	Less than 2.5W	6 to 24VDC	Less than 1.5W
AC/Special DC	120 to 347VAC	Less than 2.5W	36, 48, 120VDC	Less than 2.5W
Two-wire 120V AC/DC	120VAC	Less than 2.5W	120VDC	Less than 2.5W
Self-Powered	120 to 347VAC	Less than 3W	Nickel-Cadmium Battery	Min. 2 hours

## ORDERING INFORMATION

SERIES	LEGEND	FACES/MOUNTING	ENCLOSURE COLOUR	VOLTAGE	OPTIONS
EP= plastic sign	Blank= pictogram	1= single face, universal mounting 2= double face, universal mounting 3= universal face, universal mounting	W= factory white B= black	I= 120 to 347VAC; Self-Powered / 2 hours U= universal 120 to 347VAC; 6 to 24VDC U00= 120 to 347VAC only U36= 120 to 347VAC; 36VDC U48= 120 to 347VAC; 48VDC U120= 347VAC; 120VDC 24= 6 to 24VDC 2120= 120VAC/VDC	TP= tamper-proof screws* VR= vandal resistant shield with tamper-proof screws*  * Not available with universal face

EXAMPLE: EP1WUVR

Unlike EXIT signs, the pictogram sign is not available in double arrow configurations.

Project/Location:

Contractor:

Date:

Prepared by:

# Premier™ Series

## Thermoplastic Exit Sign



### FEATURES

- Durable, injection-molded, thermoplastic housing
- Long-life, energy-efficient **ALINGAP** LED light source
- Universal mounting - supplied standard with two stencil plates, red diffusing lens and backplate
- Universal, field-selectable snap in/out chevrons
- Available for wall, end or ceiling mounting
- Energy efficient - consumes less than 3.5W
- Normal AC and emergency DC operation with dual AC input of 120V/347V and universal DC input of 6V to 48V
- Comes with the **Emergi-Lite®** EZ2 canopy for quick and easy installation - see page 40 for more information
- CSA certified, meets or exceeds CSA 22.2 No. 141 requirements

### TYPICAL SPECIFICATIONS

Supply and install the **Emergi-Lite® Premier™ Series** Exit Sign. The standard equipment shall operate with a dual-voltage input of 120/347VAC with less than 2W of consumption and a universal two-wire DC input voltage from 6VDC to 48VDC at less than 2.5W for single and double face signs. The exit shall be suitable for wall, end, or ceiling mount. The faceplate shall be constructed of durable high impact thermoplastic. No screws are necessary to hold the faceplate or the back plate to the housing. The faceplates shall come standard with snap in/out chevrons. The frame shall consist of one-piece factory white thermoplastic. The light source shall be light emitting diodes (LEDs). The LEDs shall provide illumination in normal and emergency operation and shall be mounted inside the exit housing. Red LED technology shall be **ALINGAP**. An LED-sensitive diffuser shall be mounted in front of the LEDs to provide the 6" high by 3/4" stroke letters with even illumination. The Exit Sign shall be C860 approved. The Exit Sign in a Self-Powered configuration shall be equipped with a sealed, maintenance-free Nickel-Cadmium battery. The equipment shall recharge the battery in 24 hours and stay illuminated at least 90 minutes upon AC failure.

The Self-Powered model equipped with advanced diagnostic shall self-test by simulating a power failure for one minute every 30 days, 30 minutes every 60 days and 90 minutes every 360 days. A diagnostic circuit shall continuously monitor the performance of the battery, charger module and LED lamps. Upon failure detection the system shall display the error on the AC pilot lamp, which will change color from green to red and will flash with a specific code. The red light shall be steady-on in case of "Battery Disconnect"; it shall flash with one blink for "Battery failure", two blinks for "Charger failure" and four blinks for "LED lamp failure. A label with the diagnostic legend shall be visible next to the pilot light.

The equipment shall be **Emergi-Lite®** Model: \_\_\_\_\_.

### WIRE GUARDS



nexus®

460.0079-E	Wall Mount
460.0027-E	End Mount
460.0028-E	Ceiling Mount

### DIMENSIONS

Dimensions are approximate and subject to change.

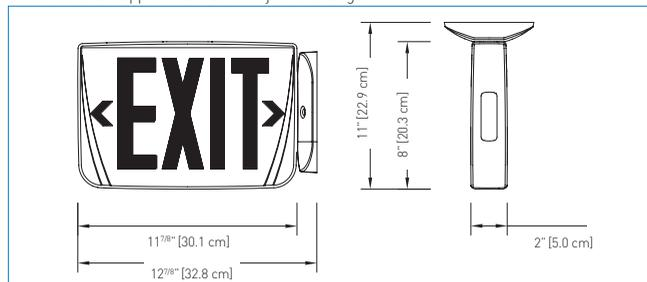

### POWER CONSUMPTION AND UNIT RATING

MODEL	AC SPECS		DC SPECS	
AC only	120/347VAC	Less than 2.5W	-	-
AC/DC remote	120/347VAC	Less than 2W	6 to 48VDC	Less than 1.5W
Self-Powered	120/347VAC	Less than 3.5W	Nickel-Cadmium Battery	Minimum 90 minutes
Self-Powered with diagnostic	120/347VAC	Less than 3W	Nickel-Cadmium Battery	Minimum 90 minutes

### PREMIER™ FAMILY



Premier™ Combo Series

P. 56-57



Premier™ Battery Series

P. 116-117

### ORDERING INFORMATION

SERIES	COLOUR	UNIT CAPACITY	VOLTAGE	LEGEND COLOUR	OPTIONS
PRE= LED plastic universal Exit Sign	W= factory white B= black	AC= AC only AC2CI= dual AC circuit (2X 120V) UD= 120/277 or 120/347VAC & 6 to 48VDC IN= Self-Powered Nickel-Cadmium IDN= Self-Powered with self diagnostics Nickel-Cadmium NEX= NEXUS® system interface* NEXRF= wireless NEXUS® system interface*  *Self-Powered models only	2= 120/277VAC 3= 120/347VAC	R= red G= green R1= red single face* R2= red double face* G1= green single face* G2= green double face*  *Used for special wording signs	TP= tamper-proof screws* VRTP= polycarbonate shield with tamper-proof screws* BA= brushed aluminum stencil 990.0119-E= tamper-proof bit**  *Specify single or double face, red or green. ** One bit needed per order

EXAMPLE: PREWAC2R



# Premier™ Series

## Thermoplastic Combination Unit

Project/Location: \_\_\_\_\_

Contractor: \_\_\_\_\_

Date: \_\_\_\_\_

Prepared by: \_\_\_\_\_

### FEATURES

The Premier™ Series of combination units (emergency light battery unit with an Exit Sign) are designed with aesthetics, ease of installation and performance in mind.

- One-pack combination of battery unit and Exit Sign, a compact and contemporary design
- Durable injection-molded thermoplastic housing with push-to-snap design
- Available in single or double face configurations both with means for ceiling mounting
- Comes with the Emergi-Lite® Premier™ E2Z canopy and field-selectable snap chevrons for quick and easy installation
- Exit Sign module illuminated by long-life ALINGAP red LEDs
- Two MR16 halogen lamps, shielded by a clear polycarbonate cover
- Optional MR16 LED lamps with life expectancy 50,000+ hours
- Sealed, maintenance-free, Lead-Calcium or Nickel-Metal-Hydride batteries
- Remote load capacity up to 92W
- Dual voltage input: 120/347VAC or 120/277VAC.
- Optional vandal-resistant shield with tamper-proof screws
- Certified CSA C22.2 No.141
- Optional advance diagnostics circuitry available

### TYPICAL SPECIFICATIONS

Supply and install the Emergi-Lite® Premier™ Series combination emergency light battery unit and Exit Sign. The standard equipment shall operate with a dual voltage input of 120/347VAC. The unit shall be suitable for wall or ceiling mount.

The unit frame and face plates shall be made of injection-molded durable high-impact thermoplastic and come standard with snap in/out chevrons. No screws are necessary to hold the faceplate or backplate to the housing. The one-piece thermoplastic frame is molded in white (optional black). The faceplates shall feature a uniformly illuminated legend. The light source shall be light emitting diodes (LED) and shall provide illumination in normal and emergency operation and shall be mounted inside the combination housing. Red LED technology shall be ALINGAP. An LED-sensitive diffuser shall be mounted behind the legend to provide the 6" high by 3/4" stroke letters with even illumination.

The unit shall be equipped with two emergency heads with tool-less adjustable swivels (lamps of 12W or less) and long-life MR-16 type lamps of \_\_\_ V and \_\_\_ W. Each lamp shall be protected by a snap-on, shock-absorbent, transparent polycarbonate cover.

The unit shall be equipped with a test switch and a green pilot light, located on the face plate above the EXIT legend. The battery charger shall be driven by a micro-controller. All electronic circuitry (charger, LED driver, LED's) shall be installed on a single printed circuit board PCB.

The unit equipped with self-testing / self-diagnostic features shall automatically self test for one minute every 30 days, 10 minutes in the 6th month and 30 minutes annually. When a fault is detected, the bi-color pilot light shall turn from green to red and shall flash, identifying the source of the failure: battery, charger circuitry, lamp load, LED strip. The Exit Sign module shall be CSA-C860 approved

The combo unit shall be Emergi-Lite® Model: \_\_\_\_\_



PREMIER™ FAMILY	
	
Premier™ Exit Series	Premier™ Battery Series
P. 55	P. 116-117

### WIRE GUARDS

460.0078-E	Wall Mount
------------	------------

### POWER CONSUMPTION

MODEL	AC SPECS		WATTAGE CAPACITY				
			30MIN	1H00	1H30	2H00	4H00
Exit Sign Module	120/347VAC	Less than 2W	-	-	-	-	-
L2		0.11/0.04 A	20	15	12	8	-
L5			50	30	24	16	8
L5A			50	30	24	16	8
H5A		0.22/0.08 A	50	36	24	18	9
H10A			100	72	48	36	18

Project/Location:

Contractor:

Date:

Prepared by:

# Premier™ Series

Thermoplastic Combination Unit



## DIMENSIONS

Dimensions are approximate and subject to change.

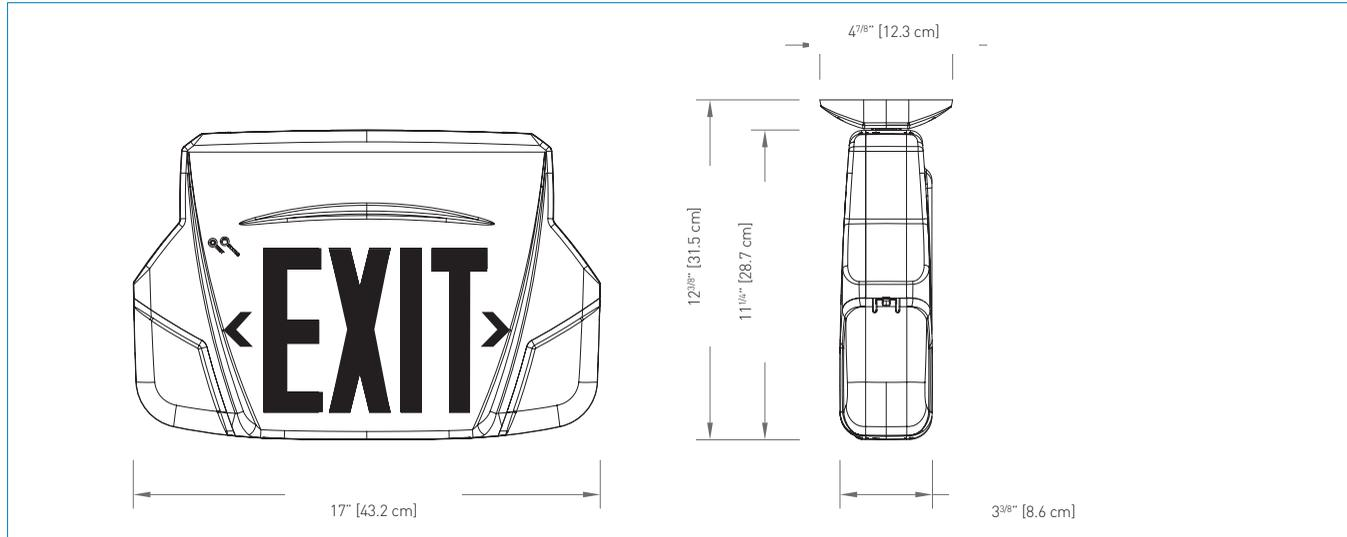

## ORDERING INFORMATION

SERIES	COLOUR	VOLTAGE	POWERPACK	LEGEND	OPTIONS	# OF HEADS	HEAD STYLE/WATTAGE
<b>PRE1</b> = single face ceiling or wall mount <b>PRE2</b> = double face ceiling mount <b>PRE1N</b> = single face wall mount (less canopy) <b>PREU</b> = universal, 2 faces backplate and canopy	<b>W</b> = factory white <b>B</b> = black	<b>3</b> = 120/347VAC <b>2</b> = 120/277VAC	<b>-L2</b> = 6V-20W Lead cal <b>-L5</b> = 6V-50W Lead cal <b>-L5A</b> = 12V-50W Lead cal <b>-H5A</b> = 12V-50W NiMH <b>-H10A</b> = 12V-100W NiMH	<b>Blank</b> = red legend <b>G</b> = green legend	<b>Blank</b> = no options <b>-TP</b> = tamper-proof screws <b>-VRTP</b> = vandal-resistant shield with tamper-proof screws <b>D3</b> = time delay (15 minutes) <b>U</b> = auto-diagnostics <b>UN</b> = auto-diagnostics, non-audible <b>990.0119-E</b> = tamper-proof bit <b>NEX</b> = NEXUS® system interface* <b>NEXRF</b> = wireless NEXUS® system interface* <b>BA</b> = brushed aluminum exit stencil	<b>Blank</b> = no heads <b>2</b> = two heads	<b>LA</b> = MR16 LED, 6V-4W <b>LG</b> = MR16 LED, 12V-4W <b>LI</b> = MR16 LED, 12V-5W <b>LJ</b> = MR16 LED, 12V-6W <b>MI</b> = MR16 halogen, 6V-6W <b>MJ</b> = MR16 halogen, 6V-10W <b>MO</b> = MR16 halogen, 12V-10W <b>MK</b> = MR16 halogen, 12V-12W
					*Consult your sales representative for options available with the NEXUS® system.		

EXAMPLE: PRE1W3-L2/2MI



# C8SRPK Series

NEMA-3R Certified "Sortie" Sign

Project/Location: \_\_\_\_\_

Contractor: \_\_\_\_\_

Date: \_\_\_\_\_

Prepared by: \_\_\_\_\_

## FEATURES

- Units are certified NEMA-3R
- Gasketed fiberglass housing designed specially for industrial applications
- Sealed, vandal-resistant clear polycarbonate faceplate
- Water, dust and oil resistant, suitable for high abuse areas, wet locations
- Long life, even illumination of the legend provided by energy-efficient **ALINGAP** technology LED light source consuming less than 3W per face
- Wall, ceiling or end mount. Mounting bracket available for ease of installation
- Normal AC and emergency DC operation – 120V to 347VAC and 6V to 24VDC input
- CSA certified, meets or exceeds CSA 22.2 No. 141 requirements

## DIMENSIONS

Dimensions are approximate and subject to change.

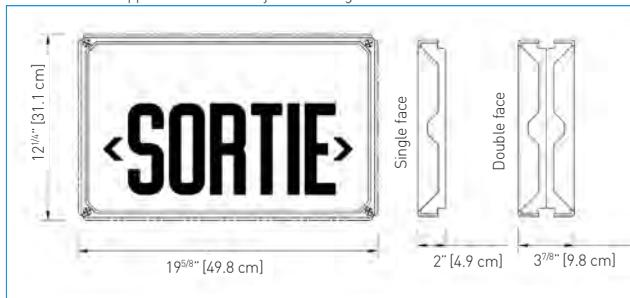

## TYPICAL SPECIFICATIONS

Supply and install **Emergi-Lite® C8SRPK Series** "SORTIE" Exit Signs. The equipment shall operate with universal two-wire AC input voltage from 120VAC to 347VAC at less than 1.5W and universal two-wire DC input voltage from 6VDC to 24VDC at less than 1.5W per face.

The sign housing shall be of grey fiberglass, specially designed for industrial environments. The sealed faceplate shall be gasketed, completely transparent, high abuse and vandal resistant, and will feature an even illuminated legend.

The light source illuminating the legend shall be **ALINGAP** technology red LEDs. The exit in a Self-Powered configuration shall include a magnetic test switch and a Nickel-Cadmium battery. The Exit Sign shall stay illuminated during emergency operation for at least 60 minutes upon AC failure.

The Exit Sign shall be CSA-C860 approved and meets CSA 22.2 No.141. The equipment shall be **Emergi-Lite®** Model: \_\_\_\_\_ .

## WIRE GUARDS

460.0103-E	Wall Mount
460.0104-E	Ceiling Mount



## POWER CONSUMPTION AND UNIT RATING

MODEL	AC SPECS		DC SPECS	
AC/DC standard, red	120 to 347VAC	Less than 1.5W	6 to 24VDC	Less than 1.5W
AC/special DC, red	120/277/ 347VAC	Less than 2.5W	36 or 48 or 120VDC	Less than 2.5W
Self-Powered, red	120 to 347VAC	Less than 3W	Nickel-Cadmium battery	Minimum 60 minutes

Note: double face models have double the power consumption above.

## ORDERING INFORMATION

SERIES	SUPPLY AND VOLTAGE
<b>C8SRPK1</b> = SORTIE, single face, wall, end and ceiling mount <b>C8SRPK2</b> = SORTIE, double face, wall, end or ceiling mount	<b>U</b> = 120 - 347VAC 6/12/24VDC <b>EM120-2W</b> = 120VAC, 120VDC 2 wires <b>U36</b> = 120/277/347VAC - 36VDC 4 wires <b>U48</b> = 120/277/347VAC - 48VDC 4 wires <b>U120</b> = 120/277/347VAC - 120VDC 4 wires <b>I</b> = Self-Powered, 120-347VAC

EXAMPLE: C8SRPK1U

Special wording available. see page \_\_\_\_\_. Please consult your sales representative.

Project/Location:

Contractor:

Date:

Prepared by:

# C8ESPK & C8SEPK Series

NEMA-3R Certified Bilingual Sign



## FEATURES

- Certified NEMA-3R
- Gasketed fiberglass housing designed specifically for industrial applications
- Grey finish
- Sealed, vandal-resistant polycarbonate faceplate
- Wall or ceiling mounting; wall or ceiling brackets available for easy installation
- Normal AC and emergency DC operation – 120 to 347V AC input; 6 to 24 DC input
- Meets or exceeds CSA 22.2 No. 141.



## WIRE GUARDS

460.0103-E	Wall Mount
460.0104-E	Ceiling Mount

## DIMENSIONS

Dimensions are approximate and subject to change.

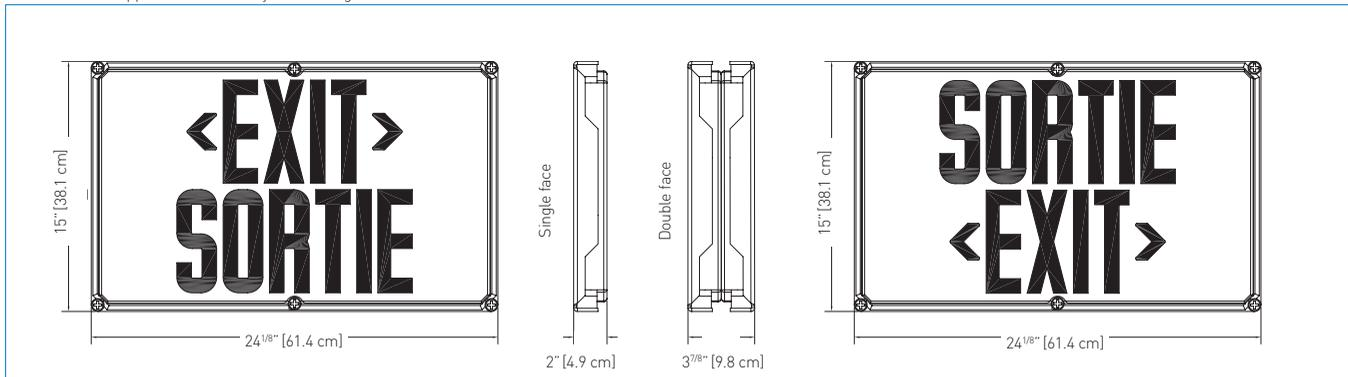

## TYPICAL SPECIFICATIONS

Supply and install **Emergi-Lite® C8ESPK or C8SEPK Series** Bilingual LED Exit Sign. The equipment shall operate with universal two-wire AC input voltage from 120VAC to 347VAC at less than 3W per face and universal two-wire DC input voltage from 6VDC to 24VDC at less than 3W per face. The housing shall be of gray fiberglass, gasketed, specially designed for industrial environments. The sealed front cover shall be constructed of heavy-duty vandal-resistant transparent polycarbonate of 4mm thickness and shall be bent around the back box for increased rigidity. The front cover will feature an even illuminated legend with the text "EXIT" and "SORTIE" positioned one on top of the other.

The light source shall be the new **ALINGAP** technology red LED. The equipment shall be suitable for wall or ceiling mount and be designed specifically for high abuse areas, wet locations, dust and oil-tight applications. The equipment in a Self-Powered configuration shall stay illuminated during emergency operation for at least 60 minutes upon AC failure.

The equipment shall be NEMA-3R and C-860 approved and meets CSA 22.2 No. 141.

The equipment shall be **Emergi-Lite®** Model: \_\_\_\_\_.

## POWER CONSUMPTION AND UNIT RATING

MODEL	AC SPECS		DC SPECS	
	AC/DC, red	120 to 347VAC	Less than 3W	6 to 24VDC
Self-Powered, red	120 to 347VAC	Less than 5W	Nickel-Cadmium battery	Minimum 60 minutes

Note: double face models have double the power consumption above.

## ORDERING INFORMATION

SERIES	POWER SOURCE AND VOLTAGE
<b>C8ESPK1</b> = single face EXIT over SORTIE <b>C8SEPK1</b> = single face SORTIE over EXIT <b>C8ESPK2</b> = double face EXIT over SORTIE <b>C8SEPK2</b> = double face SORTIE over EXIT	<b>-U</b> = 120 to 347VAC, 6 to 24VDC <b>-I</b> = Self-Powered, 120 to 347VAC

EXAMPLE: C8ESPK1-U



# C8SRPK-P Series

NEMA-3R Certified Combination Unit

Project/Location:	_____
Contractor:	_____
Date:	_____
Prepared by:	_____

## FEATURES

- This unit is ideal for schools, parking garages, public places, transit platforms and security areas such as jails
- Units are NEMA-3R certified
- Gasketed fiberglass housing designed specially for industrial applications
- Sealed, vandal-resistant clear polycarbonate faceplate
- Fully integrated unit with charger and rechargeable battery
- Water and snow resistant, suitable for areas subject to vandalism and wet locations
- Solid state charger circuitry – capable of full recharge within 24 hours
- Low voltage disconnect circuitry
- Sealed, dust-tight transfer relay
- Exit light source is **ALINGAP** technology LED
- Power pack includes a magnetic test switch and a high charge pilot light
- In emergency mode, the long life, sealed nickel battery provides power to the Exit Sign and lamp heads for a minimum of 30 minutes
- CSA certified, meets or exceeds CSA 22.2 No. 141 requirements

## TYPICAL SPECIFICATIONS

Supply and install **Emergi-Lite® C8SRPK-P Series** industrial combo unit. The unit shall be fabricated of industrial grade polycarbonate designed specifically for industrial environments. The sealed front cover shall be fabricated of high abuse and vandal-resistant polycarbonate, and feature an evenly illuminated legend. The word "SORTIE" shall be illuminated by long life LEDs consuming less than 1.5W per face. The light source shall be **ALINGAP** technology red LED. The Exit Sign shall be certified NEMA-3R and designed specifically for applications such as high abuse areas, wet locations, environments requiring dust and oil tight equipment or cold temperatures. It shall be designed to provide normal AC illumination and upon AC failure, the Exit Sign and lamp heads shall stay illuminated in emergency mode for a minimum of 30 minutes. The power pack is supplied with a magnetic test switch and a high charge pilot light.

The combo unit shall be CSA-C860 and NEMA-3R certified and meets CSA 22.2 No. 141.

The equipment shall be **Emergi-Lite®** model: \_\_\_\_\_.

## WIRE GUARDS

460.0034-E	Wall Mount
460.0104-E	Ceiling Mount
460.0124-E	Double Face, End Mount



Project/Location: \_\_\_\_\_

Contractor: \_\_\_\_\_

Date: \_\_\_\_\_

Prepared by: \_\_\_\_\_

# C8SRPK-P Series

NEMA-3R Certified Combination Unit



## DIMENSIONS

Dimensions are approximate and subject to change.

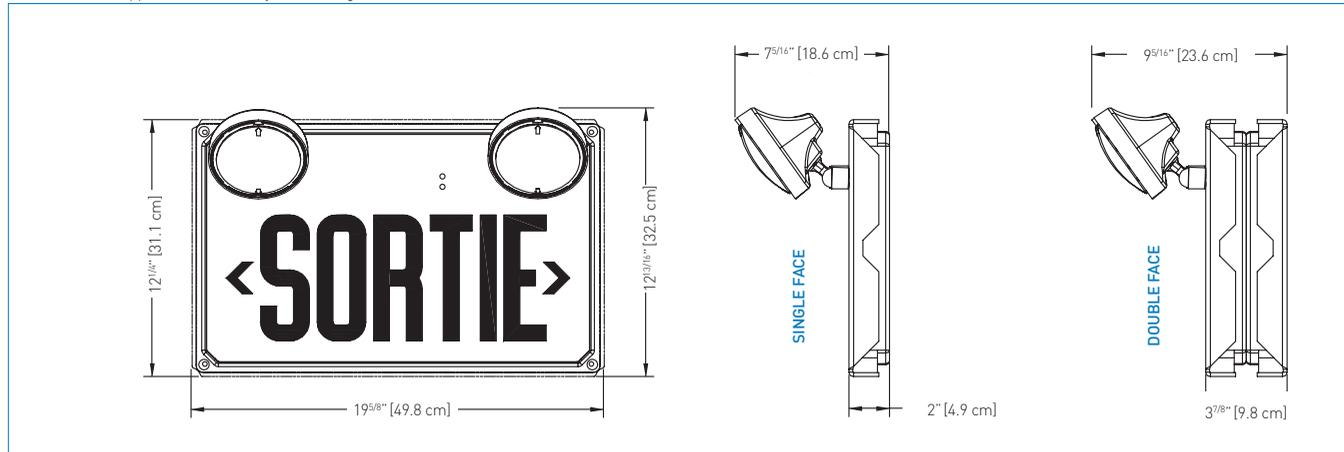

## POWER CONSUMPTION AND UNIT RATING

MODEL	AC SPECS		WATTAGE CAPACITY				
			30MIN	1H00	1H30	2H00	4H00
C8SRPK1= single face	120/347VAC	0.15/0.06 A	36	21	15	12	6
C8SRPK2= double face		0.15/0.06 A	72	42	30	24	12

Note: double face models have double the power consumption above

## ORDERING INFORMATION

SERIES	VOLTAGE	SUPPLY AND VOLTAGE	NUMBER OF HEADS	LAMP TYPE AND WATTAGE	OPTIONS
<b>C8SRPK1</b> = SORTIE, single face <b>C8SRPK2</b> = SORTIE, double face	Blank= 120/347VAC	<b>P3</b> = 6V-36W <b>P7</b> = 6V-72W	<b>Blank</b> = no heads <b>/1</b> = one head <b>/2</b> = two heads	<b>Blank</b> = tungsten, 6V-9W, par 36 <b>-18</b> = tungsten, 6V-18W, par 36 <b>-25</b> = tungsten, 6V-25W, par 36 <b>H</b> = halogen, 6V-8W, sealed beam <b>H12</b> = halogen, 6V-12W, sealed beam <b>H20</b> = halogen, 6V-20W, sealed beam <b>Q</b> = halogen, 6V-8W, par 36 <b>Q12</b> = halogen, 6V-12W, par 36 <b>Q20</b> = halogen, 6V-20W, par 36 <b>S</b> = tungsten, 6V-8W, sealed beam <b>S18</b> = tungsten, 6V-18W, sealed beam <b>S25</b> = tungsten, 6V-25W, sealed beam	FP= lens with teflon coating

Rubber heads also available.

EXAMPLE: C8SRPK1P3H



# Survive-All™ EN Series

NEMA-4X & NSF Certified  
Pictogram Sign

Project/Location:	_____
Contractor:	_____
Date:	_____
Prepared by:	_____

## FEATURES

- NEMA-4X Certified
- NSF compliant for food processing
- Polymeric enclosure is fully gasketed around lens and canopy to secure against water leaks
- Sealed, heavy-duty, vandal-resistant polycarbonate face plate
- Suitable for cold weather: -40°C for AC/DC and -20°C for Self-Powered models (option: -CW)
- Tamper-resistant, concealed test switch with magnetic action
- White LED light source
- Supplied standard with two pictogram films per face, for direction selection
- Meets or exceeds CSA 22.2 No.141-10 standard for pictogram Exit Signs
- Universal AC input: two-wire 120 to 347VAC; Standard DC input: two-wire 6 to 24VDC
- Energy efficient – consumes less than 2.5W in AC or DC-remote mode
- Self-Powered models deliver two hours of back-up lighting



## DIMENSIONS

Dimensions are approximate and subject to change.

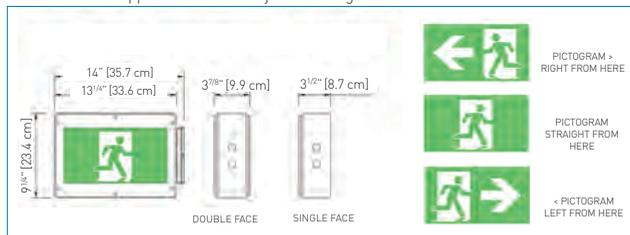

## SURVIVE-ALL™ NEMA 4X & NSF CERTIFIED FAMILY

<b>ENC SERIES</b>	<b>LPEX600 SERIES</b>	<b>LPEX600-N SERIES</b>	<b>NXM SERIES</b>
<b>EF39 &amp; EF39P SERIES</b>			
P. 64	P. 63	P. 65	P.120-121
			P.148-149

## ORDERING INFORMATION

SERIES	FACES/ MOUNTING	COLOUR	VOLTAGE	OPTIONS
EN= NEMA-4X & NSF pictogram exit sign	1= single face universal mounting 2= double face universal mounting	W= factory white B= black	I= 120 to 347VAC; Self-Powered / 2 hours ID2= 120/347VAC; Self-Powered / 2 hours c/w non-audible diagnostic ID2= 120/ 277VAC; Self-Powered / 2 hours c/w non-audible diagnostic U= universal 120 to 347VAC; 6 to 24VDC U00= 120 to 347VAC only U36= 120 to 347VAC; 36VDC U48= 120 to 347VAC; 48VDC U120= 120 to 347VAC; 120VDC EM120-2W= 2-wires 120VAC/VDC	Blank= no options NEX= NEXUS® system interface* NEXRF= wireless NEXUS® system interface* CW= cold-weather [-20°C for ID & ID2 only, -40°C for AC/DC]  *Note: some options are not available with the NEXUS® system

EXAMPLE: EN1W1CW

## TYPICAL SPECIFICATIONS

Supply and install the **Emergi-Lite® Survive-All™ EN Series** pictogram Exit Signs. The equipment shall be certified for NEMA- 4X and designed specifically for high abuse areas, wet locations, and cold weather applications. The equipment frame shall be of industrial grade polyvinyl chloride with a gasket around lenses and canopy. The faceplate(s) shall be constructed of heavy-duty vandal-resistant polycarbonate and feature an even illuminated legend. Each face plate shall come standard with two legend films for pictogram and direction selection. The light source shall be white light-emitting diodes (LED). The pictogram Exit Sign shall operate with universal 2-wire AC input voltage of 120 to 347VAC at less than 2.5W and universal 2-wire DC input voltage from 6 to 24VDC at less than 1W for single and double face signs. The Self-Powered model shall include a concealed green pilot light and magnet-sensitive test switch, shall use a sealed Nickel-Cadmium battery of 2.4V nominal voltage and shall stay illuminated during emergency operation for at least two hours upon AC failure. When specified, the Self-Powered model shall include auto-test functions: it shall execute automatic tests for 5 minutes every 30 days, 30 minutes every 60 days and two hours annually. When a fault is detected, the bi-colour pilot light shall turn from green to red and flash following a particular code. The code description shall be visible on a label next to the pilot light to identify the failure type: battery, charger circuitry, or LED lamps.

The pictogram Exit Sign shall be listed CSA 22.2 No.141-10 standard. The equipment shall be **Emergi-Lite®** Model: \_\_\_\_\_

## POWER CONSUMPTION AND UNIT RATING

MODEL	AC SPECS		DC SPECS	
AC-only	120 to 347VAC	Less than 2.5W	-	-
AC/DC standard	120 to 347VAC	Less than 2.5W	6 to 24VDC	Less than 1W
AC/Special DC	120 to 347VAC	Less than 2.5W	36, 48, 120VDC	Less than 2.5W
Two-wire 120V AC/DC	120VAC	Less than 2.5W	120VDC	Less than 2.5W
Self-Powered	120 to 347VAC	Less than 3W	Nickel-Cadmium battery	Min. 2 hours
Auto test	120 / 347VAC	Less than 3.5W	Nickel-Cadmium battery	Min. 2 hours

## WIRE GUARDS

460.0079-E	Wall mount
460.0027-E	End mount
460.0028-E	Ceiling mount

Project/Location:

Contractor:

Date:

Prepared by:

# Survive-All™ LPEX600 Series

Polyvinyl Chloride Exit Sign



## FEATURES

- NEMA-4X certified
- NSF certified for food processing
- Polyvinyl chloride enclosure is fully gasketed around lens and canopy to prevent water infiltration
- Sealed faceplate of heavy-duty, vandal-resistant polycarbonate with evenly illuminated legend
- Suitable for cold weather: -40°C on non Self-Powered sign and -25°C on Self-Powered ("CW" option)
- Tamper-resistant magnetic test switch
- Self-diagnostic circuitry standard on all Self-Powered models
- Energy efficient – consumes less than 3W in AC or DC mode
- Normal AC and emergency DC operation – 120 to 347V universal AC dual tap; 6 to 48V universal DC
- NEXUS® compatible
- Meets or exceeds CSA 22.2 No. 141.



nexus®



NEMA-4X

## DIMENSIONS

Dimensions are approximate and subject to change.

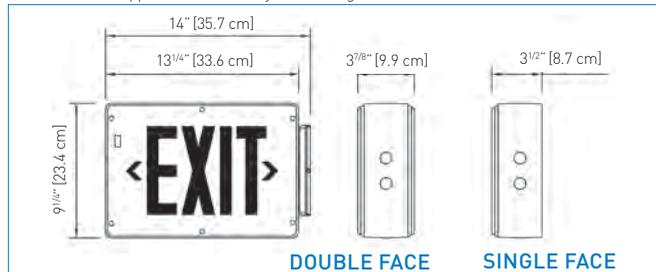

### SURVIVE-ALL™ NEMA 4X & NSF CERTIFIED FAMILY

<b>ENC SERIES</b>	<b>EN SERIES</b>	<b>LPEX600-N SERIES</b>	<b>NXM SERIES</b>	<b>EF39 &amp; EF39P SERIES</b>
P. 64	P. 62	P. 65	P.120-121	P.148-149

## ORDERING INFORMATION

SERIES	FACES/MOUNTING	HOUSING FACEPLATES COLOURS	VOLTAGE	OPTIONS	4X
LPEX60= NEMA-4X & NSF Exit Sign	2= single face, universal mount 3= double face, universal mount	WW= white/white BB= black/black BW= black/ white WB= white/black GW= grey/ white GB= grey/black WA= white/aluminum BA= black/aluminum GA= grey/aluminum	U= universal 120-347VAC, 6-48VDC (-40°C standard) ID= 120-347VAC, Self-Powered c/w diagnostics (non-audible) EM120-2W= 120VAC, 120VDC 2 wires	Blank= no options -G= green legend CW= cold weather (-25°C for Self-Powered) NEX= NEXUS® system interface* NEXRF= wireless NEXUS® system interface*	4X = approved NEMA-4X and NSF

EXAMPLE: LPEX602WWU4X

## TYPICAL SPECIFICATIONS

Supply and install **Emergi-Lite® Survive-All™ LPEX600 Series** LED Exit Signs. The equipment shall operate with universal two-wire AC input voltage from 120VAC to 347VAC at less than 3W and universal two-wire DC input voltage from 6VDC to 48VDC at less than 2W for single and double face signs. The equipment frame shall be of industrial grade polyvinyl chloride with a gasket around lenses and canopy designed specifically for hostile environments. The faceplate(s) shall be constructed of heavy-duty vandal-resistant polycarbonate and feature an even illuminated legend. The light source shall be light emitting diodes (LED). Red LED technology shall be **ALINGAP**. An LED-sensitive diffuser shall be mounted behind the legend to provide the 6" high by 3/4" stroke letters with even illumination. The exit shall be certified for NEMA- 4X and designed specifically for high abuse areas, wet locations, and cold weather -20°C (-4°F) applications.

The Self-Powered model shall stay illuminated during emergency operation for at least 90 minutes upon AC failure and shall include a magnetic test switch and self-testing and self-diagnostic functions. The equipment shall automatically self test for 5 minutes every 30 days, 30 minutes every 60 days and 90 minutes annually. A "Service Required" lamp shall be located near the test switch and flash when a fault is detected. A two-LED diagnostic display shall be located inside the equipment and shall identify the eventual source of failure (battery, charger circuitry, or LED lamps).

The Exit Sign shall be CSA-C860 approved and meets CSA 22.2 No. 141.

The equipment shall be **Emergi-Lite®** Model: \_\_\_\_\_ .

## POWER CONSUMPTION AND UNIT RATING

MODEL	AC SPECS	DC SPECS
AC/DC red	120 to 347VAC Less than 3W	6 to 48VDC Less than 2W
AC/DC green	120 to 347VAC Less than 3W	6 to 48VDC Less than 2W
Self-Powered red	120 to 347VAC Less than 3W	Nickel-Cadmium battery Min. 90 minutes
Self-Powered green	120 to 347VAC Less than 3W	Nickel-Cadmium battery Min. 90 minutes

## WIRE GUARDS

460.0079-E	Wall Mount
460.0027-E	End Mount
460.0028-E	Ceiling Mount



# Survive-All™ ENC Series

NEMA-4X & NSF Certified  
Pictogram Combination Unit

Project/Location: \_\_\_\_\_

Contractor: \_\_\_\_\_

Date: \_\_\_\_\_

Prepared by: \_\_\_\_\_

## FEATURES

- Certified NEMA-4X for wall or ceiling mount
- NSF certified certified for use in food processing areas
- Meets or exceeds CSA 22.2 No.141-10 standard for pictogram Exit Signs
- Polyvinyl chloride frame, with built-in gasket to prevent water infiltration
- Sealed, vandal-resistant faceplate of polycarbonate
- Legend illuminated by long-life white LED's
- Comes standard with two pictogram films per face, for direction selection
- Two high-performance MR16 LED lamps shielded by a clear polycarbonate cover
- Optional 5W LED emergency lights provide 60' of egress illumination on a 6-foot wide path
- Sealed, maintenance-free Lead-Calcium or Nickel-Cadmium batteries
- Remote load capacity: covers with 4W LED lights 100' up to 230' of egress illumination
- Comes standard with auto-diagnostic
- Cold-weather option: -40°C (-40°F) with only 14W extra power consumption

nexus® NEMA-4X



## DIMENSIONS

Dimensions are approximate and subject to change.

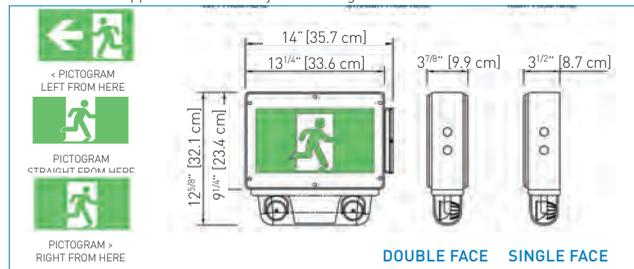

## SURVIVE-ALL™ NEMA 4X & NSF CERTIFIED FAMILY

EN SERIES	LPEX600 SERIES	LPEX600-N SERIES	NXM SERIES	EF39 & EF39P SERIES
P. 62	P. 63	P. 65	P.120-121	P.148-149

## ORDERING INFORMATION

SERIES	FACES / MOUNTING*	HOUSING COLOUR	BATTERY TYPE AND POWER	HEAD STYLE AND WATTAGE	OPTIONS
ENC= NEMA-4X & NSF pictogram exit combo unit	1= single face 2= double face  *Universal mounting	B= black W= factory white	6N36= 6V-36W Nickel-Cadmium 12N60= 12V-60W Nickel-Cadmium	Blank= no heads LA= MR16 LED, 6V-4W LG= MR16 LED, 12V-4W LI= MR16 LED, 12V-5W LJ= MR16 LED, 12V-6W MI= MR16 halogen, 6V-6W MJ= MR16 halogen, 6V-10W MK= MR16 halogen, 12V-12W	Blank= advanced diagnostic, non-audible (standard) -2= 120/277VAC input D3= time delay (15 minutes) NEX= NEXUS® system interface* NEXRF= wireless NEXUS® system interface* CW= cold-weather -40°C (-40°F) to + 25°C (77°F) only with 6V single-face units U= advanced diagnostic *Some options are not available with NEXUS®.

EXAMPLE: ENC2W12N60LD7

## TYPICAL SPECIFICATIONS

Supply and install **Emergi-Lite® Survive-All™ ENC Series** combination emergency light battery unit and pictogram Exit Sign. Designed specifically for industrial environments, the equipment frame shall be of industrial grade polyvinyl chloride with gaskets around both sides of frame contour. The back plate shall be made of 1/8" thick aluminum sheet and shall include knock-outs for installation on an electrical box. The faceplate(s) shall be constructed of heavy-duty vandal-resistant clear polycarbonate and feature a uniformly illuminated pictogram legend. Each face plate shall come standard with two legend films for pictogram and direction selection. The light source shall be long-life white light-emitting diodes (LED). The unit shall have attached a lower compartment containing two emergency heads with adjustable swivels and long-life MR-16 LED lamps of \_\_\_ V and \_\_\_ W. The heads shall be installed on a shield housing made of rigid thermoplastic and shall be protected by a shock-absorbent, clear polycarbonate cover. The standard AC input voltage shall be 120/347VAC. The unit shall be equipped with a magnetic test switch and an LED pilot light protected by the clear face plate. The unit shall perform auto-test functions managed by a micro-controller and shall automatically self-test for one minute every 30 days, 10 minutes in the 6th month and 30 minutes annually. When a fault is detected, the bi-colour pilot light shall turn from green to red and flash following a particular code. The code description shall be displayed on a label next to the pilot light to identify the failure type: battery, charger circuitry, LED lights for the signage, or emergency lights. The combination unit shall meet or exceed the standard CSA C22.2 No.141-10. The equipment shall be **Emergi-Lite® Model:** \_\_\_\_\_

## POWER CONSUMPTION

MODEL	AC SPECS	EMERGENCY POWER FOR LAMPS					
		30MIN	1H00	1H30	2H00	4H00	
Pictogram Sign Module	120/347VAC	Less than 2.5W	-	-	-	-	-
ENC-6L36	120/347VAC	0.10/0.03 A	36	21	15	12	-
ENC-6L36-CW		0.25/0.08 A	36	21	15	12	-
ENC-6N36		0.10/0.03 A	36	30	20	16	8
ENC-6N36-CW		0.25/0.08 A	36	30	20	16	8
ENC-12N60		0.18/0.06 A	60	40	30	20	10

## WIRE GUARDS WITH HEADS

460.0078-E	Wall Mount
460.0060-E	End or Ceiling Mount

Project/Location:

Contractor:

Date:

Prepared by:

# Survive-All™ LPEX600-N Series

NEMA-4X & NSF Certified  
Combination Unit



## FEATURES

- NEMA-4X certified for wall or ceiling mount
- NSF certified for food processing
- High efficiency MR16 lamps up to 12V, 12W or white LED emergency lights
- Continuous self-diagnostic monitoring and monthly self-testing
- Fully automatic charger is solid state
- Non-intrusive magnetic test switch
- Cold weather (-40°C) option
- Comes standard with tamper-proof screws
- NEXUS® compatible
- Sealed maintenance-free Nickel Cadmium battery
- Meets or exceeds CSA 22.2 No. 141

nexus®



NEMA-4X



## DIMENSIONS

Dimensions are approximate and subject to change.

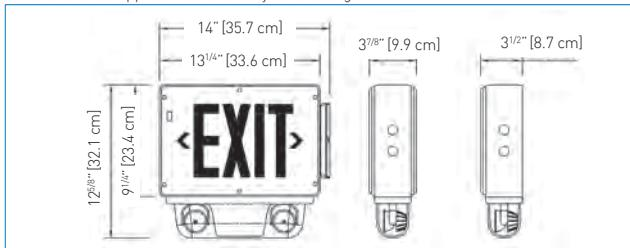

Note: double face models have double the power consumption above.

## SURVIVE-ALL™ NEMA 4X & NSF CERTIFIED FAMILY

EN SERIES	LPEX600 SERIES	ENC SERIES	NXM SERIES	EF39 & EF39P SERIES
P.62	P.63	P.64	P.120-121	P.148-149

## WIRE GUARDS WITHOUT HEADS

460.0079-E	Wall Mount
460.0027-E	End Mount
460.0028-E	Ceiling Mount

## ORDERING INFORMATION

SERIES	FACES	HOUSING/FACE COLOUR	VOLTAGE	POWERPACK	OPTIONS	# OF HEADS	HEAD STYLE AND WATTAGE
LPEX60= NEMA 4X & NSF Certified*	2= single face 3= double face	WW= white/white WB= white/black WA= white/aluminum BB= black/black BA= black/aluminum GA= grey/aluminum GW= grey/white GB= grey/black	Blank= 120 to 347VAC -2= 120/277VAC	-N3= 6V-36W -N6A= 12V-60W	Blank= advanced diagnostics non-audible (standard) -G= green legend U= advanced diagnostics audible NEX= NEXUS® system interface* NEXRF= wireless NEXUS® system interface* CW= cold weather (-40°C)** *Consult your sales representative for options available with the NEXUS® system. **Available in LPEX602 only. Single face only.	Blank= no heads 2= two heads	LA= MR16 LED, 6V-4W LG= MR16 LED, 12V-4W LI= MR16 LED, 12V-5W LJ= MR16 LED, 12V-6W MI= MR16 halogen, 6V-6W MJ= MR16 halogen, 6V-10W MK= MR16 halogen, 12V-12W

EXAMPLE: LPEX602WW-N3CW/2MI

## TYPICAL SPECIFICATIONS

Supply and install **Emergi-Lite® Survive-All™ LPEX600-N** combination of unit equipment and Exit Sign series. The equipment shall operate under two input voltage, 120VAC or 347VAC. The equipment frame shall be of industrial grade polyvinyl chloride with a gasket around lenses and canopy designed specifically for hostile environments. The unit shall be certified for NEMA-4X for wall and ceiling mount designed specially for high abuse areas, wet locations, and cold weather (CW option). The faceplate(s) shall be constructed of heavy-duty vandal-resistant polycarbonate and feature an even illuminated legend. The legend light source shall be light emitting diodes (LED). Red LED technology shall be **ALINGAP**. Emergency lights shall be fully adjustable and high efficiency MR16 lamps. The **Emergi-Lite®** Advanced Diagnostic Microcontroller board shall supply the rated load for minimum of 1/2 hour to 87.5% of the rated battery voltage. The unit shall be rated 120/347 V, 60 Hz and be CSA listed. The unit shall have an output of \_\_\_\_\_ V \_\_\_\_\_ W. The battery charger shall be driven by a micro-controller and shall include functions of Lockout, Brownout Circuits, and Low Voltage Disconnection. It protects the unit from over-current, short-circuit, and reverse polarity. The unit shall self-test for 1 minute every 30 days, 10 minutes on the 6th month and 30 minutes every 12 months. The unit shall be capable of full recharge in compliance with CSA specifications. The unit shall be furnished with a magnetic test switch. A "Service Required" lamp shall be located near the test switch and flash when a fault is detected. A four-LED diagnostic display shall be located inside the equipment and shall identify the source of failure: battery, charger circuitry, LED lamps or emergency lights. The Exit Sign shall be listed CSA-C22.2 No. 141 and CSA-C860 approved.

The equipment shall be **Emergi-Lite®** Model: \_\_\_\_\_ .

## POWER CONSUMPTION

MODEL	AC SPECS	WATTAGE CAPACITY					
		30MIN	1H00	1H30	2H00	4H00	
Exit Sign Model	Less than 2W	-	-	-	-	-	
LPEX60-N3	120/347VAC	0.15/0.05 A	36	30	20	15	8
LPEX60-N3CW		0.25/0.08 A	36	30	20	15	8
LPEX60-N6A		0.27/0.09 A	60	40	30	24	12

## WIRE GUARDS WITH HEADS

460.0078-E	Wall Mount
460.0060-E	End or Ceiling Mount



# EH Series

Pictogram Sign  
Hazardous Locations  
Class I Division 2- compliant

Project/Location: \_\_\_\_\_

Contractor: \_\_\_\_\_

Date: \_\_\_\_\_

Prepared by: \_\_\_\_\_

## FEATURES

- Compliant Class I Division 2, Groups A, B, C and D as per CSA C22.2 No.137-M1981
- Class I Zone 2 Groups IIA, IIB, IIC
- Temperature Code T6 (maximum + 85°C (185°F)) as per Canadian Electrical Code, Part I and CSA C22.2 No.137-M1981
- High-impact thermoplastic frame with built-in gasket to secure against liquid leaks
- Sealed, heavy-duty, vandal-resistant polycarbonate face plate(s)
- Concealed pilot light and test switch with magnetic action
- Long-life white LED light source
- Supplied standard with two pictogram films per face, for direction selection
- Meets or exceeds CSA 22.2 No.141-10 standard for pictogram Exit Signs
- Universal AC input: two-wire 120 to 347VAC; standard DC input: two-wire 6 to 24VDC
- Energy efficient – consumes less than 2.5W in AC or DC-remote mode
- Self-Powered models come standard with auto-diagnostic functions and deliver two hours of back-up legend illumination
- Suitable for cold-weather: -40°C (-40°F) for AC/DC and -20°C (-4°F) for Self-Powered models (option: -CW)

## TYPICAL SPECIFICATIONS

Supply and install the **Emergi-Lite® EH Series** of pictogram Exit Signs. The equipment shall be certified for Hazardous Locations: Class I Division 2 Groups A, B, C and D with a temperature code T6 (maximum 85°C (185°F)). The equipment frame shall be of industrial grade polyvinyl chloride with a gasket around lenses and canopy. The faceplate(s) shall be constructed of heavy-duty vandal-resistant polycarbonate and feature an even illuminated pictogram legend. Each face plate shall come standard with two legend films for pictogram and direction selection. The light source shall be long-life white light-emitting diodes (LED). The pictogram Exit Sign shall operate with universal 2-wire AC input voltage of 120 to 347VAC at less than 2.5W and universal 2-wire DC input voltage from 6 to 24VDC at less than 1W for single and double face signs. The Self-Powered model shall include a concealed pilot light and magnet-sensitive test switch, shall use a sealed Nickel-Cadmium battery of 2.4V nominal voltage and shall stay illuminated during emergency operation for at least two hours upon AC failure. The Self-Powered model shall include auto-test functions: it shall execute automatic tests for 5 minutes every 30 days, 30 minutes every 60 days and two hours annually. When a fault is detected, the bi-colour pilot light shall turn from green to red and flash following a particular code. The code description shall be visible on a label next to the pilot light to identify the failure type: battery, charger circuitry, or LED lamps.

The pictogram Exit Sign shall meet or exceed the CSA 22.2 No.141-10 standard.

The equipment shall be **Emergi-Lite® Model:** \_\_\_\_\_

## POWER CONSUMPTION

MODEL	AC SPECS		DC SPECS	
AC-only	120 to 347VAC	Less than 2.5W	-	-
AC/DC standard	120 to 347VAC	Less than 2.5W	6 to 24VDC	Less than 1 W
AC/Special DC	120 to 347VAC	Less than 2.5W	36, 48, 120VDC	Less than 2.5 W
Two-wire 120V AC/DC	120VAC	Less than 2.5W	120VDC	Less than 2.5 W
Auto-diagnostic	120 / 347VAC	Less than 3.5W	Nickel-Cadmium battery	Min. two hours



## DIMENSIONS

Dimensions are approximate and subject to change.

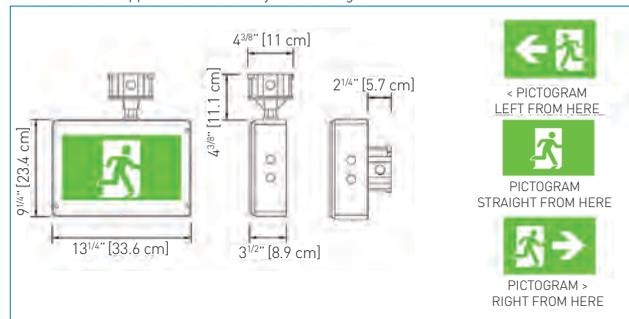

## CLASS I DIV 2 FAMILY

<b>LPEXHZ SERIES</b>	<b>EHC SERIES</b>	<b>EXHZ SERIES</b>	<b>HZM SERIES</b>	<b>EF41 SERIES</b>
P. 67	P. 68-69	P. 70-71	P.126-127	P.154

## ORDERING INFORMATION

SERIES	FACES*	HOUSING COLOUR	VOLTAGE	OPTIONS
<b>EH=</b> CL.I Div.2 pictogram Exit Sign	1= single face 2= double face  *Ceiling or wall mount only.	<b>G=</b> grey	<b>ID=</b> 120/ 347VAC; Self-Powered / 2 hours c/w non-audible diagnostic <b>ID2=</b> 120/ 277VAC; Self-Powered / 2 hours c/w non-audible diagnostic <b>U=</b> universal 120 to 347VAC; 6 to 24VDC <b>U00=</b> 120 to 347VAC only <b>U36=</b> 120 to 347VAC; 36VDC <b>U48=</b> 120 to 347VAC; 48VDC <b>U120=</b> 120 to 347VAC; 120VDC <b>EM120-2W=</b> 2-wires 120VAC/VDC	<b>NEX=</b> NEXUS® system interface* <b>NEXRF=</b> wireless NEXUS® system interface* <b>CW=</b> cold weather [-20°C for Self-Powered, -40°C for AC/DC]  *Note: some options are not available with the NEXUS® system.

EXAMPLE: EH16U

Project/Location:

Contractor:

Date:

Prepared by:

# LPEXHZ Series

Hazardous Location  
LED Exit Sign

Class I Division 2- compliant



## FEATURES

- Certified Class I Zone 2, Groups IIA, IIB and IIC
- Certified Class I Division 2, Groups A, B, C and D as per CSA C22.2 No.137-M1981
- Temperature Code: T6 (maximum 85°C as per Canadian Electrical Code, Part I and CSA C22.2 No.137-M1981)
- CSA certified, meets or exceeds CSA 22.2 No. 141 requirements
- Input voltages: 120 to 347VAC universal AC input; 6 to 48VDC universal DC input
- High impact thermoplastic frame, with built-in gasket to prevent water infiltration
- Suited for areas with the risk of presence of flammable gases, vapors or liquids able to create an explosive atmosphere
- Sealed faceplate of heavy-duty, vandal-resistant polycarbonate
- Tamper-resistant, hermetically sealed magnetic test switch
- Auto-diagnostic circuitry is standard on Self-Powered models
- Sealed, maintenance-free, Nickel-Cadmium batteries
- Batteries recharge as per CSA requirements and provide 90 minutes of emergency operation
- Long-life, energy-efficient **ALINGAP** red LED light source
- Energy efficient – consumes less than 3W in AC or DC mode
- Comes standard with industrial-grade, Die-Cast aluminum electrical box
- Suitable for cold weather: -20°C [-4°F] (Self-Powered model, "CW" option) and -40°C [-40°F] (AC only and AC-DC models)



## WIRE GUARDS

460.0080-E	Wall Mount
------------	------------

## DIMENSIONS

Dimensions are approximate and subject to change.

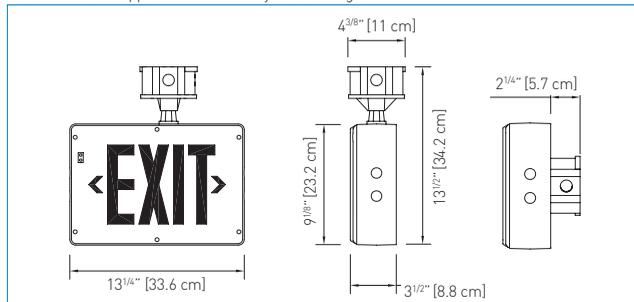

## ORDERING INFORMATION

SERIES	FACES/MOUNTING	HOUSING/FACEPLATE COLOUR	VOLTAGE	OPTIONS
LPEXHZ	2= single face, ceiling or wall mount 3= double face, ceiling mount only	GG= grey/grey	U= universal 120-347VAC, 6-48VDC ID= 120-347VAC, Self-Powered c/w non-audible diagnostics EM120-2W= 120VAC, 120VDC, 2 wires (AC only)	Blank= red legend -G= green legend -CW= cold weather -20°C Self-Powered only NEX= NEXUS® system interface* NEXRF= wireless NEXUS® system interface* *NEXUS® option with Self-Powered models only

EXAMPLE: LPEXHZ2GGU

## TYPICAL SPECIFICATIONS

Supply and install **Emergi-Lite® LPEXHZ Series** LED Exit Signs. The equipment shall operate with universal two-wire AC input voltage from 120VAC to 347VAC at less than 3W and universal two-wire DC input voltage from 6VDC to 48VDC at less than 2W for single and double face signs. Designed specifically for hostile environments, the equipment frame shall be of industrial grade high impact thermoplastic with a gasket around lenses and canopy. The faceplate(s) shall be constructed of heavy-duty vandal-resistant polycarbonate and feature an even illuminated legend. The light source shall be light emitting diodes (LED). Red LED technology shall be **ALINGAP**. An LED-sensitive diffuser shall be mounted behind the legend to provide the 6" high by 3/4" stroke letters with even illumination. The equipment shall be certified for Hazardous Locations: Class I Division 2 Groups A, B, C and D with a temperature code T6 Maximum 85°C (185°F). The equipment shall be designed specifically for high abuse areas, wet location, and cold weather -20°C [-4°F] applications. The Self-Powered model shall stay illuminated during emergency operation for at least 90 minutes upon AC failure and shall include a magnetic test switch and self-testing/self-diagnostic functions. The equipment shall automatically self test for 5 minutes every 30 days, 30 minutes every 60 days and 90 minutes annually. A "Service required" lamp shall be located near the test switch and flash when a fault is detected. A two-LED diagnostic display shall be located inside the equipment and shall identify the eventual source of failure (battery, charger circuitry, or LED lamps).

The Exit Sign shall be CSA-C860 approved and meets CSA 22.2 No. 141.

The equipment shall be **Emergi-Lite®** Model: \_\_\_\_\_

## POWER CONSUMPTION AND UNIT RATING

MODEL	AC SPECS		DC SPECS	
	Voltage	Power	Voltage	Power
AC/DC red	120 to 347VAC	Less than 3W	6 to 48VDC	Less than 2W
AC/DC green	120 to 347VAC	Less than 3W	6 to 48VDC	Less than 2W
Self-Powered red	120 to 347VAC	Less than 3W	Nickel-Cadmium battery	Min. 90 minutes
Self-Powered green	120 to 347VAC	Less than 3W	Nickel-Cadmium battery	Min. 90 minutes
120VAC/VDC 2 wires, red	120VAC	Less than 3W	120VDC	Less than 3W

Note: double face models have double the power consumption above.

## CLASS I DIV 2 FAMILY

<b>EH SERIES</b>	<b>EHC SERIES</b>	<b>EXHZ SERIES</b>	<b>H2M SERIES</b>	<b>EF41 SERIES</b>
P. 66	P. 68-69	P. 70-71	P.126-127	P.154



# EHC Series

Pictogram Exit Combination Unit  
Hazardous Locations  
Class I Division 2- compliant

Project/Location:	_____
Contractor:	_____
Date:	_____
Prepared by:	_____

## FEATURES

- Certified Class I Division 2, Groups A, B, C and D as per CSA C22.2 No.137-M1981
- Certified temperature Codes for several types of emergency lamps
- Certified CSA C22.2 No.141-10
- Polyvinyl chloride frame, with built-in gasket to prevent water infiltration
- Heavy-duty 1/8" thick aluminum back plate with keyholes for wall-mount installation
- Sealed, vandal-resistant faceplate of polycarbonate
- Legend illuminated by long-life white LEDs
- Comes standard with two pictogram films for direction selection
- Two high-performance MR16 LED lamps shielded by a clear polycarbonate cover
- 5W LED emergency lights provide 60' of egress illumination on a 6-foot wide path
- LED emergency lights provide 30-36' of egress illumination on a 6-foot wide path
- Sealed, maintenance-free Lead-Calcium or Nickel-Cadmium batteries
- Remote load capacity: covers with LED lights 100 ft up to 230 ft of egress illumination
- Comes standard with auto-diagnostic
- Cold-weather option: -40°C (-40°F) with only 14W extra power consumption



## CLASS I DIV 2 FAMILY



## TYPICAL SPECIFICATIONS

Supply and install **Emergi-Lite® EHC Series** combination emergency light battery unit and pictogram sign. Designed specifically for hazardous locations, the equipment frame shall be of industrial grade polyvinyl chloride with gaskets around both sides of the frame contour. The back plate shall be made of 1/8" thick aluminum sheet and shall include knock-outs for installation on an electrical box and four keyholes for alternative installation on a wall surface. The faceplate shall be constructed of heavy-duty vandal-resistant clear polycarbonate and feature a uniformly illuminated pictogram legend.

The unit shall come standard with two legend films for pictogram and direction selection. The light source shall be long-life white light-emitting diodes (LED). The unit shall have attached a lower compartment containing two emergency heads with adjustable swivels and long-life MR-16 LED lamps of \_\_\_ V and \_\_\_ W. The heads shall be installed on a shield housing made of cast aluminum and protected by a shock-absorbent, clear polycarbonate cover. The standard AC input voltage shall be 120/347VAC. The equipment shall be equipped with a magnetic test switch and one LED pilot light protected by the face plate.

The unit shall perform auto-test functions managed by a micro-controller and shall automatically self-test for one minute every 30 days, 10 minutes in the 6th month and 30 minutes annually. When a fault is detected, the bi-color pilot light shall turn from green to red and flash following a particular code. The code description shall be displayed on a label next to the pilot light to identify the failure type: battery, charger circuitry, LED lights for the signage, or emergency lights. The combination unit shall be approved CSA C22.2 No.141-10 and No.137-M1981 for Class I Division 2 Groups A, B, C and D.

The combination unit shall be **Emergi-Lite®** model: \_\_\_\_\_.

## TEMPERATURE CODES

LAMP RATING	TEMPERATURE CODE	MAX. TEMPERATURE	REPLACEMENT PART NUMBER
6V-10W	T3C	160°C (320°F)	580.0079
12V-12W	T3A	180°C (356°F)	580.0080
12V-20W	T2D	215°C (419°F)	580.0068

## POWER CONSUMPTION

MODEL	AC SPECS		EMERGENCY POWER AVAILABLE FOR LAMPS				
			30MIN	1H00	1H30	2H00	4H00
Pictogram Sign Module	120/347VAC	Less than 2.5W	-	-	-	-	-
EHC-6L36	120/347VAC	0.10/0.03 A	36	21	15	12	-
EHC-6L36-CW		0.25/0.08 A	36	21	15	12	-
EHC-6N36		0.10/0.03 A	36	30	20	16	8
EHC-6N36-CW		0.25/0.08 A	36	30	20	16	8
EHC-12N60		0.18/0.06 A	60	40	30	20	10

Project/Location:

Contractor:

Date:

Prepared by:

# EHC Series

Pictogram Exit Combination Unit  
Hazardous Locations  
Class I Division 2- compliant



## DIMENSIONS

Dimensions are approximate and subject to change.

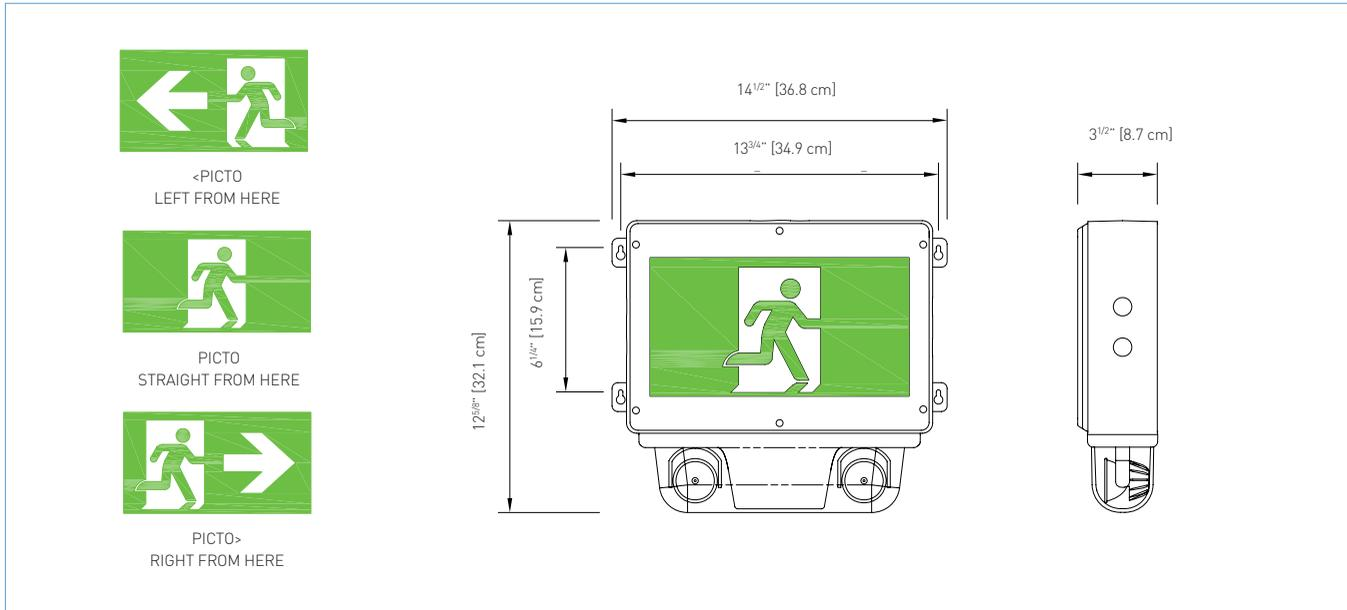

## ORDERING INFORMATION

SERIES	HOUSING COLOUR	BATTERY TYPE AND POWER	HEAD STYLE AND WATTAGE	OPTIONS	
EHC= Class I Zone 2 pictogram combo	G= grey	6L36= 6V-36W Lead-Calcium 6N36= 6V-36W Nickel-Cadmium 12N60= 12V-60W Nickel-Cadmium	Blank= no heads LA= MR16 LED, 6V-4W LG= MR16 LED, 12V-4W LI= MR16 LED, 12V-5W MJ= MR16 halogen, 6V-10W MK= MR16 halogen, 12V-12W MW= MR16 high output, 12V-20W	Blank= auto-diagnostics, non-audible -2= 120/277/VAC input D1= time delay (5 minutes) D2= time delay (10 minutes) D3= time delay (15 minutes) U= auto-diagnostics, audible	NEX= NEXUS® system interface* NEXRF= wireless NEXUS® system interface* CW= cold weather -40°C (only 6V units)

\* Consult your sales representative.

EXAMPLE: EHC6N36LD1



# EXHZ Series

Combination Unit  
Hazardous Location, Class I Zone 2

Project/Location:	_____
Contractor:	_____
Date:	_____
Prepared by:	_____

## FEATURES

- Certified Class I Zone 2, Groups IIA, IIB and IIC
- Certified Class I Division 2, Groups A, B, C and D as per CSA C22.2 No.137-M1981
- Certified temperature Codes for several types of emergency lamps
- Certified CSA C22.2 No141
- Certified CSA C860
- Polymeric frame, with built-in gasket to prevent water infiltration
- Heavy-duty 1/8" thick aluminum back plate with keyholes for secure wall-mount installation
- Sealed faceplate of heavy-duty, vandal-resistant polycarbonate
- Suited for areas with the risk of flammable gases, vapors or liquids that can create an explosive atmosphere
- Exit Sign module illuminated by long-life, energy-efficient **ALINGAP** red LEDs
- Two MR16 halogen lamps, shielded by a cast aluminum housing and a polycarbonate cover
- Sealed, maintenance-free, Lead-Calcium or Nickel-Cadmium batteries
- Remote load capacity
- Comes standard with auto-diagnostic functions
- 1/2" electrical conduit entry on both sides and at the top
- NEXUS® compatible (for more information on NEXUS®, contact your sales representative)

## TYPICAL SPECIFICATIONS

Supply and install **Emergi-Lite® EXHZ Series** combination emergency light battery unit and LED Exit Sign. Designed specifically for hostile environments, the equipment frame shall be of industrial grade polymer with gaskets around both sides of the frame contour. The back plate shall be made of 1/8" thick aluminum sheet and shall include knockouts for installation on an electrical box and four keyholes for alternative installation on a wall surface. The faceplate shall be constructed of heavy-duty vandal-resistant polycarbonate and feature a uniformly illuminated legend. The light source shall be light emitting diodes (LED). Red LED technology shall be **ALINGAP**. An LED-sensitive diffuser shall be mounted behind the legend to provide the 6" high by 3/4" stroke letters with even illumination. When specified, the equipment shall have attached a lower compartment containing two emergency lights with adjustable swivels and long-life MR-16 halogen lamps of \_\_\_\_\_ V and \_\_\_\_\_ W. The lamps shall be shielded by cast aluminum housing and protected by a shock-absorbent, transparent polycarbonate cover. The equipment shall be certified for Hazardous Locations: Class I Division 2 Groups A, B, C and D. The standard AC input voltage shall be 120/347VAC. The equipment shall be equipped with a magnetic test switch located behind the face plate and two LED pilot lights: AC-on and "Service required". The unit shall include self-testing/self-diagnostic functions monitored by a micro-controller and shall automatically self test for one minute every 30 days, 10 minutes in the 6th month and 30 minutes annually. The "Service required" LED shall light when a fault is detected. A four-LED diagnostic display located inside the equipment shall identify the source of the failure (battery, charger circuitry, or lamp load).

The Exit Sign module shall be CSA-C860 approved.  
The combination unit shall be **Emergi-Lite®** Model: \_\_\_\_\_ .



## WIRE GUARDS

460.0078-E	Wall Mount
------------	------------

## TEMPERATURE CODES

LAMP RATING	TEMPERATURE CODE	MAX. TEMPERATURE	REPLACEMENT PART NUMBER
6V-10W	T3C	160°C	580.0079
12V-12W	T3A	180°C	580.0080
12V-20W	T2D	215°C	580.0068
6V-4W LED	T4A	120°C	580.0097
12V-4W LED	T4A	120°C	580.0093
12V-5W LED	T4A	120°C	580.0104

## CLASS I DIV 2 FAMILY

<b>ENC SERIES</b>	<b>EHC SERIES</b>	<b>EH SERIES</b>	<b>HZM SERIES</b>	<b>EF41 SERIES</b>
P. 67	P. 68-69	P. 66	P.126-127	P.154

## POWER CONSUMPTION

MODEL	AC SPECS		WATTAGE CAPACITY				
			30MIN	1H00	1H30	2H00	4H00
EXHZ-L3	120/347VAC	0.15/0.06 A	36	21	15	12	-
EXHZ-N3		0.15/0.06 A	36	30	20	15	-
EXHZ-L6A		0.30/0.10 A	60	40	30	20	10
EXHZ-H10A		0.30/0.10 A	100	72	40	36	18

Project/Location:

Contractor:

Date:

Prepared by:

# EXHZ Series

Combination Unit  
Hazardous Location, Class I Zone 2



## DIMENSIONS

Dimensions are approximate and subject to change.

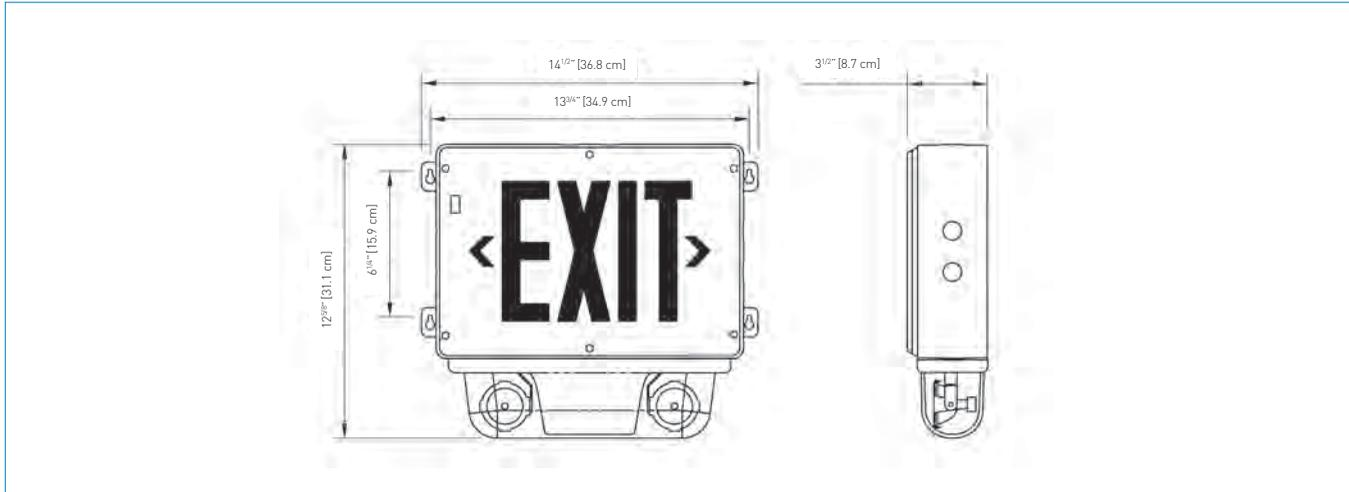

## ORDERING INFORMATION

SERIES	HOUSING FACE COLOUR	VOLTAGE	CAPACITY	LEGEND COLOUR	OPTIONS	NUMBER OF HEADS	HEAD STYLE/ WATTAGE
EXHZ= combo Exit Class I Div. 2	GG= grey/grey	Blank= 120/347VAC 2= 120/277VAC	N3= 6V- 36W Nickel-Cadmium N6A= 12V - 60W Nickel-Cadmium H10A= 12V-100W NiMH	Blank= red legend G= green legend	U= auto-diagnostics, audible UN= auto-diagnostics, non-audible NEX= NEXUS® wired system interface* NEXRF= NEXUS® wireless system interface*	Blank= no heads /2= two heads	MJ= MR16 halogen, 6V-10W MK= MR16 halogen, 12V-12W MW= MR16 high output, 12V-20W LA= 6V-4W LED LG= 12V-4W LED LI= 12V-5W LED

\*Consult your sales representative for options with the NEXUS® system.

EXAMPLE: EXHZGGN3U12MJ



# EX Series

Hazardous Location "Exit" Sign  
TS Series Transfer Panel

Project/Location:	_____
Contractor:	_____
Date:	_____
Prepared by:	_____

## FEATURES

- CSA Certified for use in hazardous locations:
  - Class I, Division 1 and 2, Groups A, B, C, D
  - Class II, Division 1 and 2, Groups E, F, G
  - Class III, Divisions 1 and 2
- Very low Temperature Codes (see table)
- Listed CSA C22.2 No.137-M1981
- Listed CSA 22.2 No.141-10
- Lighting fixture of die-cast aluminum with gray epoxy powder coat finish
- Legend housing of industrial-grade 14-gauge steel with gray enamel finish
- Supplied standard with two pictogram films per face, for direction selection
- Long-life white LED light source
- Two-wire AC/DC input available in 6, 12, 24 or 120V
- Energy efficient – consumes maximum 4.0W in AC and DC mode

## TYPICAL SPECIFICATIONS

Supply and install the **Emergi-Lite® EX Series** remote pictogram exit signs. The lighting fixture shall have a die-cast aluminum body with gray epoxy powder coat finish and a transparent glass globe. The light source shall be long-life Light-Emitting Diodes (LED) in a lamp assembly rated \_\_\_V. The LED assembly shall emit white light and shall consume less than 4W in AC or DC current. The legend housing shall be of industrial-grade 14-gauge steel with gray enamel finish. The face plate(s) shall consist of three layers: a white translucent panel, a green/clear legend film and a clear Polycarbonate panel for rigidity enforcement. Each face plate shall come standard with two legend films per face, for direction selection.

The equipment shall be certified CSA C22.2 No.137-M1981 for Hazardous Locations: Class \_\_, Division \_\_, Groups \_\_\_\_\_ with the temperature code: \_\_\_\_\_.

The equipment shall be certified CSA 22.2 No.141-10

The equipment shall be **Emergi-Lite®** Model: \_\_\_\_\_.



## POWER CONSUMPTION AND UNIT RATING

MODEL	AC SPECS		DC SPECS	
AC/DC	6VAC	Maximum 4W	6VDC	Maximum 4W
	12VAC		12VDC	
	24VAC		24VDC	
	120VAC		120VDC	

\*NOTE: Exit Signs of 6,12 or 24 V must be connected through transfer panels; maximum five Exit Signs per panel.

## CERTIFICATION GUIDE FOR EX SERIES (40°C AMBIENT)

SEVERITY CODE	S1	S2	S3	S4
TEMPERATURE CODE	T6	T6	T4A	T6
CSA/UL RATING	Maximum 85° C	Maximum 85° C	Maximum 85° C	Maximum 85° C

\*NOTE: Exit Signs of 6,12 or 24 V must be connected through transfer panels; maximum five Exit Signs per panel.

## PRODUCT SELECTION GUIDE

ENVIRONMENT	SEVERITY CODE
Class I Div.1 Groups A, B	S1
Class I Div.1 Groups C, D	S2
Class I Div.2 Groups A, B, C, D	S3
Class II Div. 1 & 2 Groups E, F, G Class III Div.1 and 2	S4

Project/Location:

Contractor:

Date:

Prepared by:

# EX Series

Hazardous Location "Exit" Sign  
TS Series Transfer Panel



## DIMENSIONS

Dimensions are approximate and subject to change.

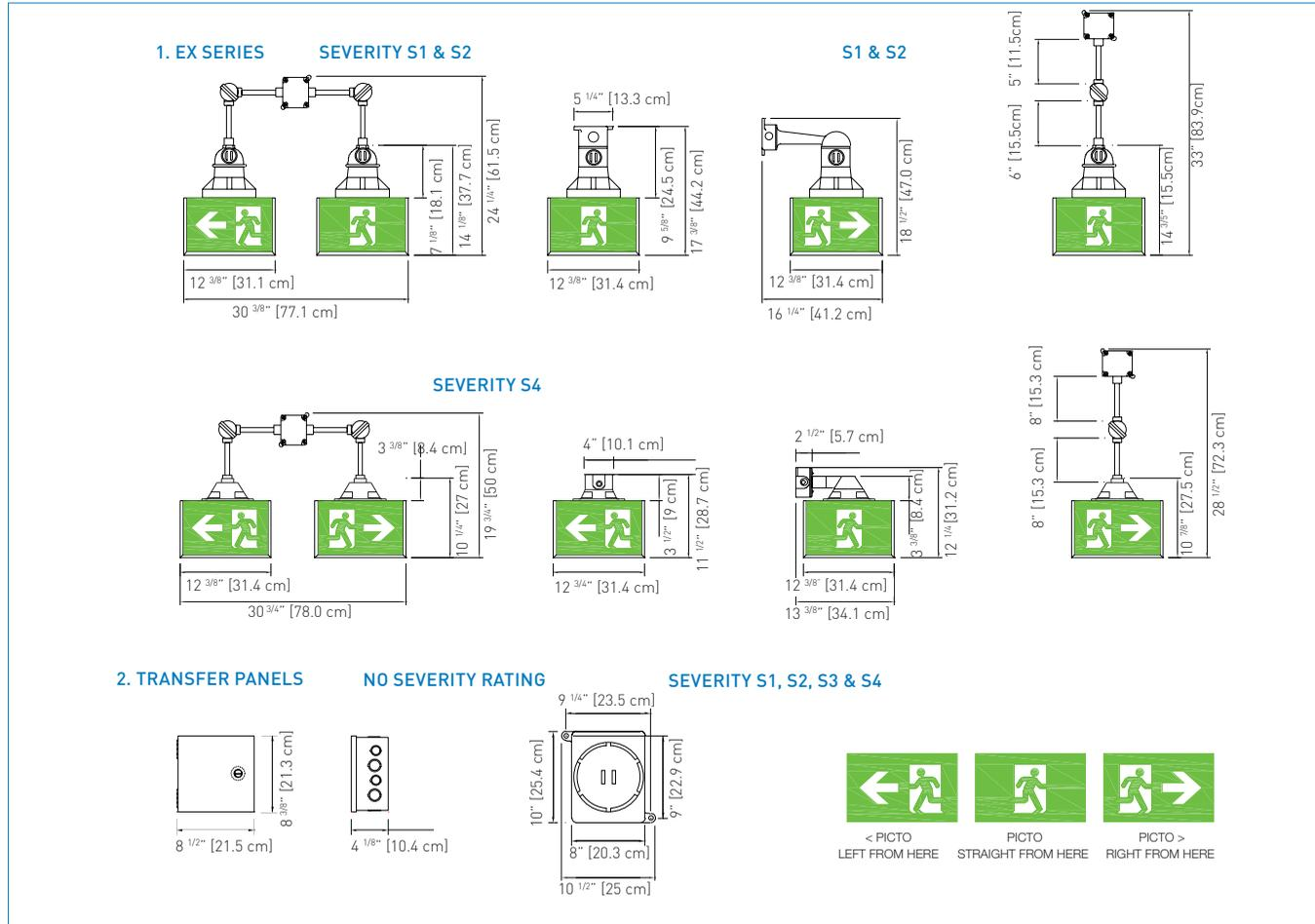

## ORDERING INFORMATION

### 1. EX SERIES

SERIES	NO. OF FACES	SEVERITY CODE	MOUNTING	INPUT VOLTAGE
EX= Hazardous Location pictogram sign	1= single face 2= double face, universal mount	S1= Class I Div.1 Gr. A, B S2= Class I Div.1 Gr. C, D S3= Class I Div.2 Gr. A, B, C, D S4= Class II Div.1&2 Gr. E, F, G Class III Div.1&2	C= Ceiling P= Pendant W= Wall*  * Wall-mount only available for severities S2, S3 and S4	6= 6V AC/DC 12= 12V AC/DC 24= 24V AC/DC 120= 120V AC/DC

EXAMPLE: EX1S1C6

Unlike EXIT signs, the pictogram sign is not available in double arrow configuration.

### 2. TRANSFER PANELS - TS SERIES

AC VOLTAGE	DC VOLTAGE	SERIES	LOAD POWER	HOUSING
120= 120VAC 347= 347VAC	-6= 6V -12= 12V -24= 24V -120= 120V	TS= Transfer Panel	25= 25W*  * 4W per pictogram sign	Blank= NEMA1



# LPEX-XP Series

Hazardous Location "Exit" Sign  
TS Series Transfer Panels

Project/Location:	_____
Contractor:	_____
Date:	_____
Prepared by:	_____

## FEATURES

### LPEX-XP Series Remote Exit Signs

- CSA Certified for use in hazardous locations:
  - Class I, Divisions 1 and 2, Groups A, B, C, D
  - Class II, Divisions 1 and 2, Groups E, F, G
  - Class III, Divisions 1 and 2
- Die-Cast aluminum body with grey epoxy powder coat finish
- Exit housing and faceplate made of industrial-grade 14-gauge steel and finished in grey enamel
- Faceplate features universal knockout chevrons
- Two-wire input circuit for both AC and DC inputs
- Available in 6, 12, 24 and 120VAC/DC
- LED lamp with **ALINGAP** LEDs; consumes less than 5W in AC and DC mode
- New, easy-to-build catalogue number based on the **Emergi-Lite®** Severity Codes
- CSA certified, meets or exceeds CSA 22.2 No. 141 requirements
- Also available as Self-Powered Exit Sign, battery unit and combo unit; see **EXP** catalogue sheet

### TS Series Transfer Switch

- Available with explosion-proof housing (Class 1, Division 1) or NEMA-1 housing (for use outside the hazardous location area)
- Standard AC input: 120VAC, optional 277VAC, 347VAC; standard DC input: 6, 12 or 24VDC
- Two-wire output with permanently present AC/DC low voltage
- Output power: 25W, can drive up to five (5) units of the **LPEX-XP** remote exit series

## TYPICAL SPECIFICATIONS

Supply and install the **Emergi-Lite® LPEX-XP Series** remote Exit Sign. The exit housing shall be industrial grade 14-gauge steel and finished in grey enamel. The faceplate will be constructed of heavy-duty 14-gauge steel and feature universal knockout chevrons and the red letters shall not be less than 6" in height with a 3/4" stroke. The sign shall come complete with a \_\_\_\_\_ Volt LED lamp, and function from one voltage source only, in AC and DC current. The LED Lamp shall use **ALINGAP** LEDs and shall consume less than 5W in either AC or DC current.

The Exit Sign shall be CSA-C860 approved and meets CSA 22.2 No. 141.

The Exit Sign shall be suitable for Class \_\_\_\_\_, Division \_\_\_\_\_, Group \_\_\_\_\_.

The Exit Sign shall be **Emergi-Lite®** Model: \_\_\_\_\_.

### TS Series Transfer Switch:

Supply and install the **Emergi-Lite® TS Series** transfer switch for hazardous location remote Exit Signs. The unit shall have two voltage inputs: \_\_\_\_\_ VAC and \_\_\_\_\_ VDC and shall be able to maintain an output of \_\_\_\_\_ V 25W for the permanent supply of a total of five remote LED Exit Signs.

The transfer switch shall be suitable for Class \_\_\_\_\_, Division \_\_\_\_\_, Group \_\_\_\_\_ or for a NEMA 1 environment.

The unit shall be **Emergi-Lite®** Model: \_\_\_\_\_.



## POWER CONSUMPTION AND UNIT RATING

MODEL	AC SPECS		DC SPECS	
AC/DC red two-wire	6VAC	Less than 5W	6VDC	Less than 5W
	12VAC		12VDC	
	24VAC		24VDC	
	120VAC		120VDC	

\*NOTE: Exit Signs of 6,12 or 24 V must be connected through transfer panels; maximum five Exit Signs per panel.

1.

ENVIRONMENT	SEVERITY CODE
Cl. I, Div. 1, Gr. B	S1
Cl. I, Div. 1, Gr. C, D	S2
Cl. I, Div. 2, Gr. B, C, D	S3
Cl. II, Div. 1 & 2, Gr. E, F, G Cl. III, Div. 1 & 2	S4

2.

CERTIFICATION GUIDE FOR LPEX-XP (40°C AMBIENT)				
Severity Code	S1	S2	S3	S4
Temperature Code	T6	T6	T3C	T3C (E.G.F.)
CSA/UL rating	Max. 85°C (185°F)	Max. 85°C (185°F)	Max. 160°C (320°F)	Max. 160°C (320°F)

Project/Location:

Contractor:

Date:

Prepared by:

# LPEX-XP Series

Hazardous Location "Exit" Sign  
TS Series Transfer Panels



## DIMENSIONS

Dimensions are approximate and subject to change.

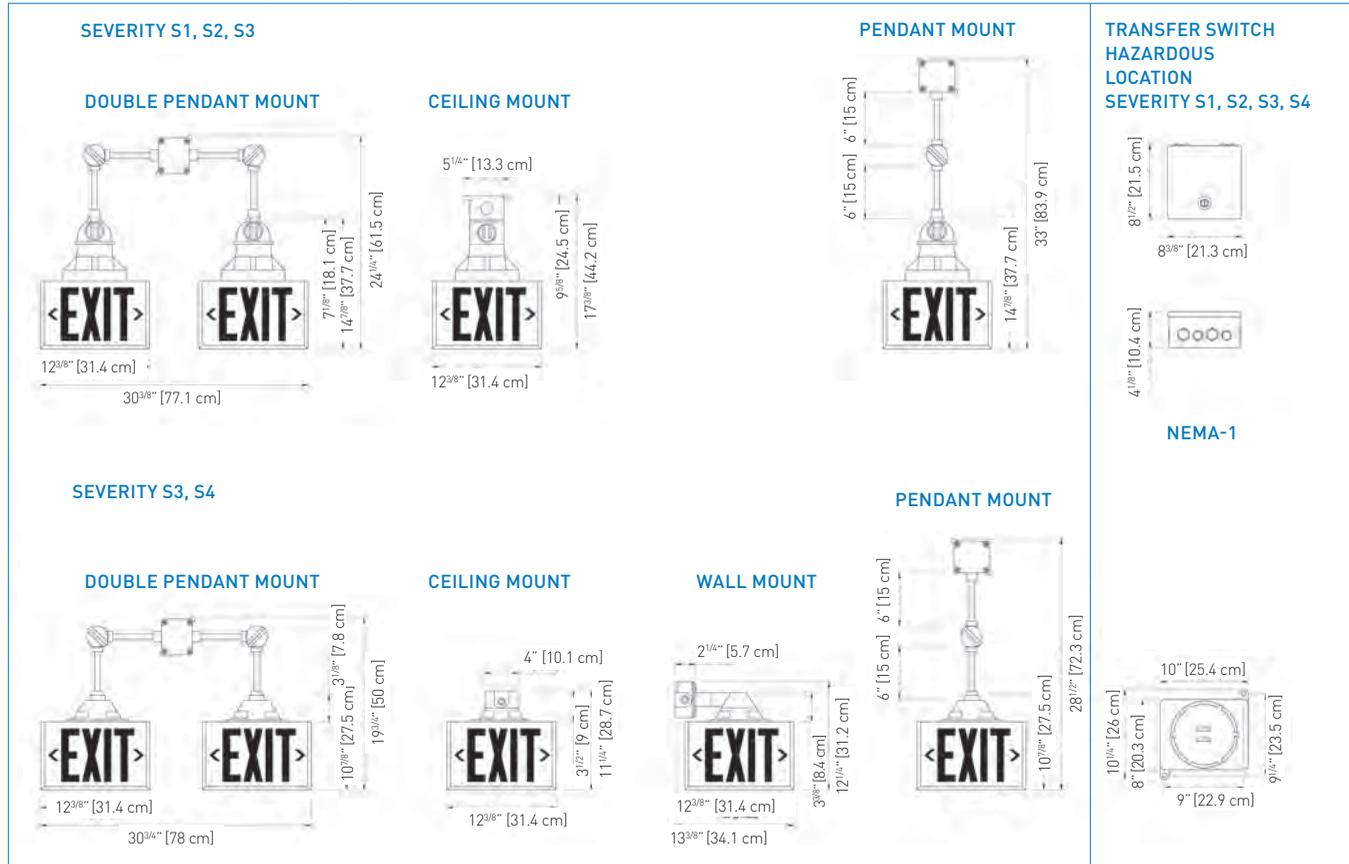

## ORDERING INFORMATION

Before ordering, identify the environment of your application: Class \_\_\_\_\_, Division \_\_\_\_\_, Group \_\_\_\_\_. Refer to table 1 for the Severity Code to use in your catalogue number. For temperature information, please see table 2.

## 3. LPEX-XP

SERIES	MOUNTING	SEVERITY CODE	VOLTAGE	LAMP TYPE
LPEXXP1= exit single face C860 LPEXXP2= exit double face C860 LED	C= ceiling P= pendant W= wall*  *Severity 2, 3 and 4 only	S1= CL.I, Div.1, Gr. A, B S2= CL.I, Div.1, Gr. C, D S3= CL.I, Div.2, Gr. A, B, C, D S4= CL.II, Div.1, & 2 Gr.E, F, G CL.III, Div.1 & 2	-EM6= 6V -EM12= 12V -EM24= 24V -EM120= 120V	Blank= LED less than 5W

EXAMPLE: LPEXXP1CSI-EM6

## 4. TRANSFER PANELS

AC VOLTAGE	DC VOLTAGE	SERIES	LOAD WATTAGE	HOUSING
120= 120VAC 347= 347VAC	-6= 6V -12= 12V -24= 24V -120= 120V	-TS= transfer switch	-25= 25W*  *5W required per DC Exit load	Blank= NEMA 1

EXAMPLE: 120-6-TS-25XP



# C8SRXP Series

“Sortie” Sign and Transfer Panels  
for Hazardous Locations

Project/Location:	_____
Contractor:	_____
Date:	_____
Prepared by:	_____

## FEATURES

### Remote Sortie Sign Series

- CSA certified for use in hazardous locations:
  - Class I, Divisions 1 and 2, Groups B, C, D
  - Class II, Divisions 1 and 2, Groups E, F, G
  - Class III, Divisions 1 and 2
- Die-Cast aluminum body with grey epoxy powder coat finish
- Sortie Sign housing and faceplate made of 14-gauge steel, grey enamel finish
- Faceplate features universal directional chevrons (knockouts)
- Two-wire circuit for both AC and DC inputs
- Available in 6, 12, 24 and 120VAC/DC
- Light source is **ALINGAP** LEDs; consumes less than 5W in AC or DC mode
- New, easy-to-build catalog number based on the **Emergi-Lite®** severity codes
- CSA certified, meets or exceeds CSA 22.2 No. 141
- Also available as Self-Powered Exit Sign, battery unit and combo unit; see **EXP** catalogue sheet

### Transfer Switch

- Available with housing for hazardous locations (Class 1, Division 1) or NEMA-1 housing (for use outside the hazardous location area)
- Standard AC input: 120VAC, optional: 277VAC, 347VAC
- Standard DC input: 6, 12 or 24VDC
- Two-wire output with permanently present AC/DC low voltage
- Output power: 25W, can drive up to five (5) remote units Series **C8SRXP**

## TYPICAL SPECIFICATIONS

Supply and install the **Emergi-Lite® C8SRXP Series** remote “SORTIE” sign. The exit housing shall be industrial grade 14-gauge steel and finished in grey enamel. The faceplate will be constructed of heavy-duty \_\_\_\_\_ 14-gauge steel and feature universal knockout chevrons and the red letters shall not be less than 6” in height with a 3/4” stroke. The sign shall come complete with a \_\_\_\_\_ Volt LED lamp, and function from one voltage source only, in AC and DC current. The LED Lamp shall use **ALINGAP** LEDs and shall consume less than 5W in either AC or DC current.

The Sortie Sign shall be CSA-C860 approved and meets CSA 22.2 No. 141.

The Sortie Sign shall be suitable for Class \_\_\_\_\_, Division \_\_\_\_\_, Group \_\_\_\_\_.

The Sortie Sign shall be **Emergi-Lite®** Model: \_\_\_\_\_.

### TS Series Transfer Switch:

Supply and install the **Emergi-Lite® TS Series** transfer switch for hazardous location remote Exit Signs. The unit shall have two voltage inputs: \_\_\_\_\_ VAC and \_\_\_\_\_ VDC and shall be able to maintain an output of \_\_\_\_\_ V 25W for the permanent supply of a total of five remote LED Exit Signs.

The transfer switch shall be suitable for Class \_\_\_\_\_, Division \_\_\_\_\_, Group \_\_\_\_\_, or for a NEMA 1 environment.

The unit shall be **Emergi-Lite®** Model: \_\_\_\_\_.



## POWER CONSUMPTION AND UNIT RATING

MODEL	AC SPECS		DC SPECS	
	AC/DC red two-wire	6VAC	Less than 5W	6VDC
12VAC		12VDC		
24VAC		24VDC		
120VAC		120VDC		

\*NOTE: SORTIE signs of 6, 12 or 24 V must be connected through transfer switch; maximum five signs per panel.

1.

ENVIRONMENT	SEVERITY CODE
Cl. I, Div. 1, Gr. B	S1
Cl. I, Div. 1, Gr. C, D	S2
Cl. I, Div. 2, Gr. B, C, D	S3
Cl. II, Div. 1 & 2, Gr. E, F, G Cl. III, Div. 1 & 2	S4

2.

CERTIFICATION GUIDE FOR C8SRXP (40°C AMBIENT)				
Severity Code	S1	S2	S3	S4
Temperature Code	T6	T6	T3C	T3C [E.G.F.]
CSA/UL rating	Max. 85°C (185°F)	Max. 85°C (185°F)	Max. 160°C (320°F)	Max. 160°C (320°F)

Project/Location:

Contractor:

Date:

Prepared by:

# C8SRXP Series

"Sortie" Sign and Transfer Panels  
for Hazardous Locations



## DIMENSIONS

Dimensions are approximate and subject to change.

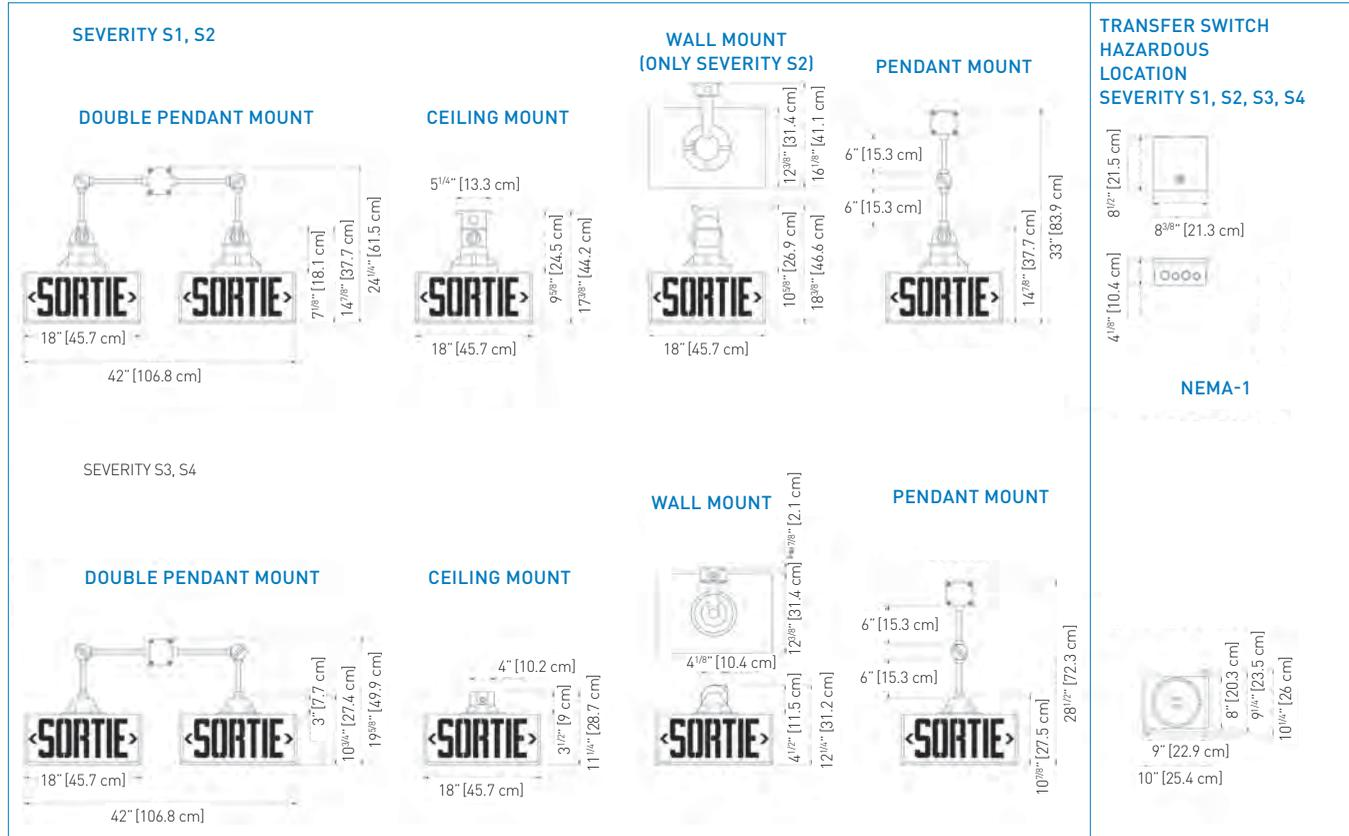

## ORDERING INFORMATION

Before ordering, identify the environment of your application: Class \_\_\_\_\_, Division \_\_\_\_\_, Group \_\_\_\_\_ .  
Refer to table 1 for the Severity Code to use in your catalogue number. For temperature information, please see table 2.

### 3. C8SRXP

SERIES	SEVERITY CODE	MOUNTING	VOLTAGE
C8SRXP1= sortie single face C8SRXP2= sortie double face	S1= CL.I, Div.1&2, Gr. B S2= CL.I, Div.1&2, Gr. C, D S3= CL.I, Div.2, Gr. B, C, D S4= CL.II, Div.1, & 2 Gr.E, F, G CL.III, Div.1 & 2	C= ceiling P= pendant W= wall* *Note: wall mount available only for severities S2, S3 and S4	6= 6V 12= 12V 24= 24V 120= 120V

EXAMPLE: C8SRXP1S1C6

### 4. TRANSFER PANELS

AC VOLTAGE	DC VOLTAGE	SERIES	LOAD WATTAGE	HOUSING
120= 120VAC 347= 347VAC	-6= 6V -12= 12V -24= 24V -120= 24V	-TS= transfer switch	-25= 25W*  *5W required per DC "Sortie" load	Blank= NEMA 1

EXAMPLE: 120-6-TS-25XP



# EXP Series

Battery Units,  
Self-Powered Exit Signs  
Combination Units

Project/Location: \_\_\_\_\_

Contractor: \_\_\_\_\_

Date: \_\_\_\_\_

Prepared by: \_\_\_\_\_

## CSA certified for use in hazardous locations

The **EXP Series** of battery equipment is designed to cover emergency lighting applications for the entire spectrum of hazardous locations, where inflammable gases, vapors, liquids, dust particles, fabrics or tissues are permanently present or are likely to exist.

In one simple-to-order catalogue family the **EXP Series** combines three traditional emergency lighting products with battery back-up: battery units with emergency lights, Self-Powered Exit Signs, and combination units with emergency lights and Exit Sign. The equipment is also available with additional emergency power capacity to drive remote heads and Exit Signs.

## FEATURES

- CSA Certified for use in hazardous locations:
  - Class I, Divisions 1 and 2, Groups B, C, D\*
  - Class II, Divisions 1 and 2, Groups E, F, G
  - Class III, Divisions 1 and 2
- Die-Cast aluminum body with grey epoxy powder coat finish; clear, impact and heat resistant prismatic glass globe
- Long-life, maintenance-free Lead-Calcium battery
- Battery charger is current limited, temperature compensated, short-circuit proof and reverse polarity protected
- Emergency heads with one or twin lamp design
- Self-Powered exit (combo) includes a transfer circuit to drive four remote LED-based remote Exit Signs
- Exit Sign uses an LED lamp with **ALINGAP** LEDs
- Exit Sign is CSA certified, meets or exceeds C860
- The Self-Powered version is also CSA C22.2 No. 141 certified



## TYPICAL SPECIFICATIONS

Supply and install the **Emergi-Lite® EXP Series** of hazardous location battery unit equipment. The battery unit housing will be constructed of Die-Cast aluminum with grey epoxy powder coat finish. The equipment shall be rated for 120, 277 or 347V, 60 Hz input and be CSA listed. The equipment shall have an output of \_\_\_\_\_ V and \_\_\_\_\_ W and shall supply the rated load for minimum of 1/2 hour to 87.5% of the rated battery voltage. The battery shall be a long-life, maintenance-free Lead-Calcium type. The charger shall be fully computer tested and have its charge voltage set in the factory to ± 1% tolerance. The charger shall be current limited, temperature compensated, short circuit proof and reverse polarity protected. The charger shall be furnished with an electronic lockout circuit, which will connect the battery when the AC circuit is activated, and an electronic brownout circuit, which will activate the emergency heads when the utility power dips below 75% of nominal voltage. Where required the equipment shall come complete with \_\_\_\_\_ heads, each of them equipped with \_\_\_\_\_ lamp(s) of \_\_\_\_\_ W. The head housing shall be Die-Cast aluminum with grey epoxy powder coat finish. The lenses shall be a clear, impact and heat resistant prismatic glass globe. The head shall be factory sealed, with no need for external seals. Where required the equipment shall come complete with one Exit Sign and will include a transfer circuit to maintain the Exit Sign permanently lighting in both normal and emergency operation. The exit housing shall be industrial grade 14-gauge steel and finished in grey enamel. The faceplate will be constructed of heavy-duty 14-gauge steel and feature universal knockout chevrons and the red letters shall not be less than 6" in height with a 3/4" stroke. The sign shall include an LED lamp with **ALINGAP** LEDs and shall consume less than 5W in either AC or battery mode.

The equipment shall be suitable for Class \_\_\_\_\_, Division \_\_\_\_\_, Group \_\_\_\_\_. The Exit Sign shall be CSA-C860 approved.

The equipment shall be **Emergi-Lite®** Model: \_\_\_\_\_.

## POWER CONSUMPTION AND UNIT RATING

MODEL	AC SPECS		WATTAGE CAPACITY				
			30MIN	1H00	1H30	2H00	4H00
06EXP36	120/347VAC	0.50/0.20 A	36	21	15	12	6
06EXP72		0.50/0.20 A	72	42	30	24	12
06EXP108		0.50/0.20 A	108	63	45	36	18
12EXP72		0.50/0.20 A	72	42	30	24	12
12EXP144		0.50/0.20 A	144	84	60	48	24
12EXP200		0.50/0.20 A	200	117	83	67	33
24EXP144		0.50/0.20 A	144	84	60	48	24
24EXP288		0.50/0.20 A	288	168	120	96	48

NOTE: The wattage capacity applies only to the battery unit. For combo or Self-Powered Exit Signs one must allocate 5W of emergency power for each sign.

1.

ENVIRONMENT	SEVERITY CODE
Cl. I, Div. 1, Gr. B	S1
Cl. I, Div. 1, Gr. C, D	S2
Cl. I, Div. 2, Gr. B, C, D	S3
Cl. II, Div. 1 & 2, Gr. E, F, G / Cl. III, Div. 1 & 2	S4

2.

CERTIFICATION GUIDE FOR EXP (40°C AMBIENT)				
Severity Code	S1	S2	S3	S4
Temperature Code	T6	T6	T3C	T3C (E.G.F.)
CSA/UL rating	Max. 85°C (185°F)	Max. 85°C (185°F)	Max. 160°C (320°F)	Max. 160°C (320°F)

NOTE: Units for Class I Group A available without test switch and pilot light allocate 5W of emergency power. Contact your sales representative.

Project/Location: \_\_\_\_\_

Contractor: \_\_\_\_\_

Date: \_\_\_\_\_

Prepared by: \_\_\_\_\_

# EXP Series

Battery Units,  
Self-Powered Exit Signs  
Combination Units



## DIMENSIONS

Dimensions are approximate and subject to change.

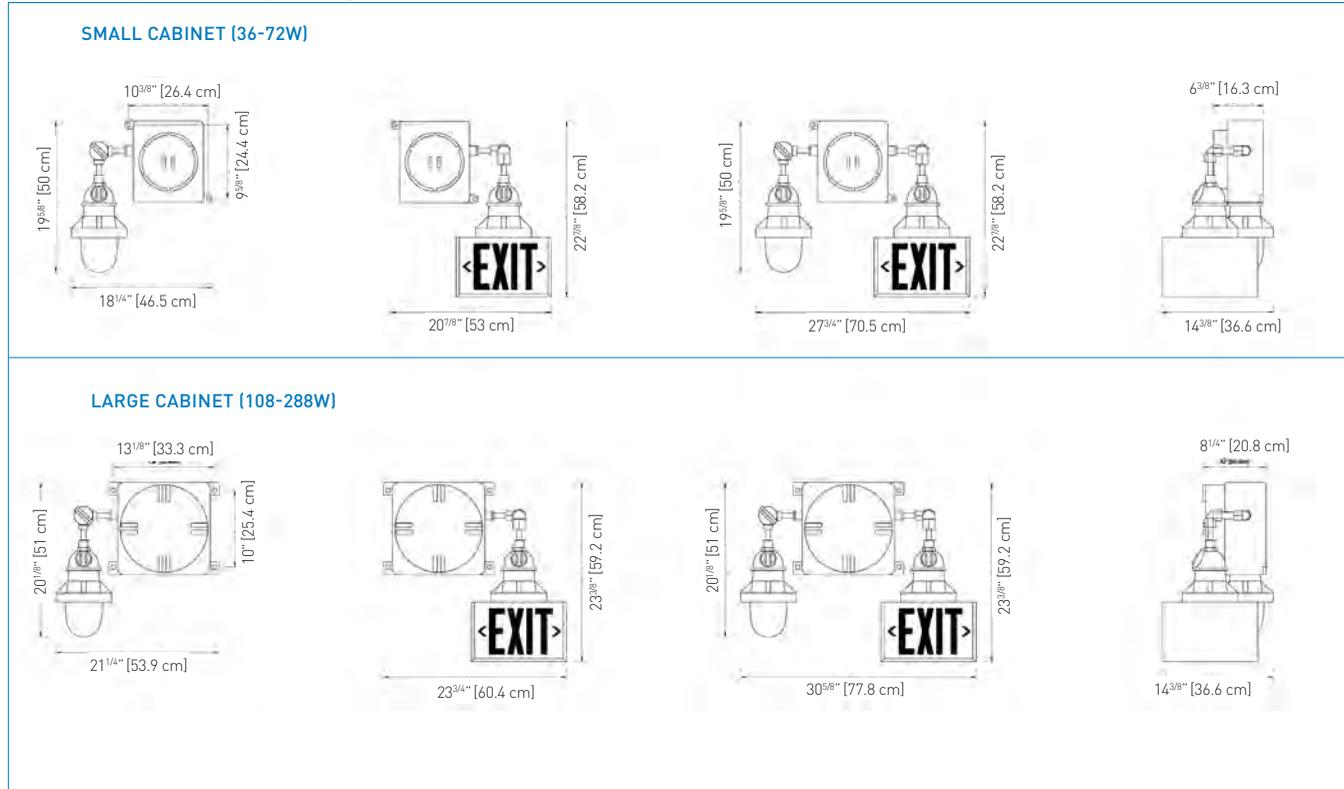

## ORDERING INFORMATION

Before ordering, identify the environment of your application: Class \_\_\_\_\_, Division \_\_\_\_\_, Group \_\_\_\_\_.  
Refer to table 1 for the Severity Code to use in your catalogue number. For temperature information, please see table 2.

### 3. EXP

DC VOLTAGE	SERIES	CAPACITY CABINET SIZE	AC VOLTAGE	OPTIONS	HEAD STYLE AND WATTAGE	SEVERITY CODE*	LAMPS
06= 6V	EXP	36= 36W 72= 72W 108= 108W	Blank= 120VAC -2= 277VAC -3= 347VAC	Blank= no options D= time delay [15 minutes] E1= single face Exit Sign, LED E2= double face Exit Sign, LED TS= transfer switch	Blank= no heads /11= single remote, 1 lamp /12= single remote, 2 lamps /21= double remote, 1 lamp	S1= CL.I, Div.1, Gr. A, B S2= CL.I, Div.1, Gr. C, D S3= CL.I, Div.2, Gr. A, B, C, D S4= CL.II, Div.1, & 2 Gr.E, F, G CL.III, Div.1 & 2	12W= halogen, 6V, 12V, 12W, quartz bi-pin 20W= halogen, 12V, 24V, 20W, quartz bi-pin
12= 12V		72= 72W 144= 144W 200= 200W					
24= 24V		144= 144W 288= 288W					

\*For temperature codes, consult your sales representative.

EXAMPLE: 06EXP36E1/21S312



# EXP Series

Battery Units,  
Self-Powered "Sortie" Signs  
Combination Units

Project/Location: \_\_\_\_\_

Contractor: \_\_\_\_\_

Date: \_\_\_\_\_

Prepared by: \_\_\_\_\_

## CSA certified for use in hazardous locations

The **EXP Series** of battery equipment is designed to cover emergency lighting applications for the entire spectrum of hazardous locations, where inflammable gases, vapors, liquids, dust particles, fabrics or tissues are permanently present or are likely to exist.

In one simple-to-order catalogue family the **EXP Series** combines three traditional emergency lighting products with battery back-up: battery units with emergency lights, Self-Powered Sortie Signs, and combination units with emergency lights and Sortie Sign. The equipment is also available with additional emergency power capacity to drive remote heads and Sortie Signs.

## FEATURES

- CSA Certified for use in hazardous locations:
  - Class I, Divisions 1 and 2, Groups A, B, C, D\*
  - Class II, Divisions 1 and 2, Groups E, F, G
  - Class III, Divisions 1 and 2
- Die-Cast aluminum body with grey epoxy powder coat finish; clear, impact and heat resistant prismatic glass globe
- Long life, maintenance-free, Lead-Calcium battery; charger is current limited, temperature compensated, short-circuit proof and reverse polarity protected
- Emergency heads with one or twin lamp design
- Sortie Sign is CSA C860 certified
- Self-Powered exit (combo) includes a transfer circuit to drive four LED-based remote Exit Signs
- Sortie Sign uses a LED lamp with **ALINGAP** LEDs
- The Self-Powered version is also CSA C22.2 No. 141 certified



## TYPICAL SPECIFICATIONS

Supply and install the **Emergi-Lite® EXP Series** of hazardous location battery unit equipment. The battery unit housing will be constructed of Die-Cast aluminum with grey epoxy powder coat finish. The equipment shall be rated for 120, 277 or 347V, 60 Hz input and be CSA listed. The equipment shall have an output of \_\_\_\_\_ V and \_\_\_\_\_ W and shall supply the rated load for a minimum of 1/2 hour to 87.5% of the rated battery voltage. The battery shall be a long-life, maintenance-free Lead-Calcium type. The charger shall be fully computer tested and have its charge voltage set in the factory to ± 1% tolerance. The charger shall be current limited, temperature compensated, short circuit proof and reverse polarity protected. The charger shall be furnished with an electronic lockout circuit, which will connect the battery when the AC circuit is activated, and an electronic brownout circuit, which will activate the emergency heads when the utility power dips below 75% of nominal voltage.

Where required the equipment shall come complete with \_\_\_\_\_ heads, each of them equipped with \_\_\_\_\_ lamp(s) of \_\_\_\_\_ W. The head housing shall be Die-Cast aluminum with grey epoxy powder coat finish. The lenses shall be a clear, impact and heat resistant prismatic glass globe. The head shall be factory sealed, with no need for external seals.

Where required the equipment shall come complete with one Exit Sign and will include a transfer circuit to maintain the Exit Sign permanently lighting in both normal and emergency operation. The exit housing shall be industrial grade 14-gauge steel and finished in grey enamel. The faceplate will be constructed of heavy-duty 14-gauge steel and feature universal knockout chevrons and the red letters shall not be less than 6" in height with a 3/4" stroke. The sign shall include an LED lamp with **ALINGAP** LEDs and shall consume less than 5W in either AC or battery mode.

The equipment shall be suitable for Class \_\_\_\_\_, Division \_\_\_\_\_, Group \_\_\_\_\_  
The Exit Sign shall be CSA-C860 and approved.  
The equipment shall be **Emergi-Lite®** Model: \_\_\_\_\_.

## POWER CONSUMPTION AND UNIT RATING

MODEL	AC SPECS		WATTAGE CAPACITY				
			30MIN	1H00	1H30	2H00	4H00
06EXP36	120/347VAC	0.50/0.20 A	36	21	15	12	6
06EXP72		0.50/0.20 A	72	42	30	24	12
06EXP108		0.50/0.20 A	108	63	45	36	18
12EXP72		0.50/0.20 A	72	42	30	24	12
12EXP144		0.50/0.20 A	144	84	60	48	24
12EXP200		0.50/0.20 A	200	117	83	67	33
24EXP144		0.50/0.20 A	144	84	60	48	24
24EXP288		0.50/0.20 A	288	168	120	96	48

1.

ENVIRONMENT	SEVERITY CODE
Cl. I, Div. 1, Gr. A, B	S1
Cl. I, Div. 1, Gr. C, D	S2
Cl. I, Div. 2, Gr. A, B, C, D	S3
Cl. II, Div. 1 & 2, Gr. E, F, G / Cl. III, Div. 1 & 2	S4

2.

CERTIFICATION GUIDE FOR EXP (40°C AMBIENT)				
Severity Code	S1	S2	S3	S4
Temperature Code	T6	T6	T3C	T3C (E.G.F.)
CSA/UL rating	Max. 85°C	Max. 85°C	Max. 160°C	Max. 160°C

NOTE: Units for Class I Group A available without test switch and pilot light allocate 5W of emergency power. Contact your sales representative.

Project/Location: \_\_\_\_\_

Contractor: \_\_\_\_\_

Date: \_\_\_\_\_

Prepared by: \_\_\_\_\_

# EXP Series

Battery Units,  
Self-Powered "Sortie" Signs  
Combination Units



## DIMENSIONS

Dimensions are approximate and subject to change.

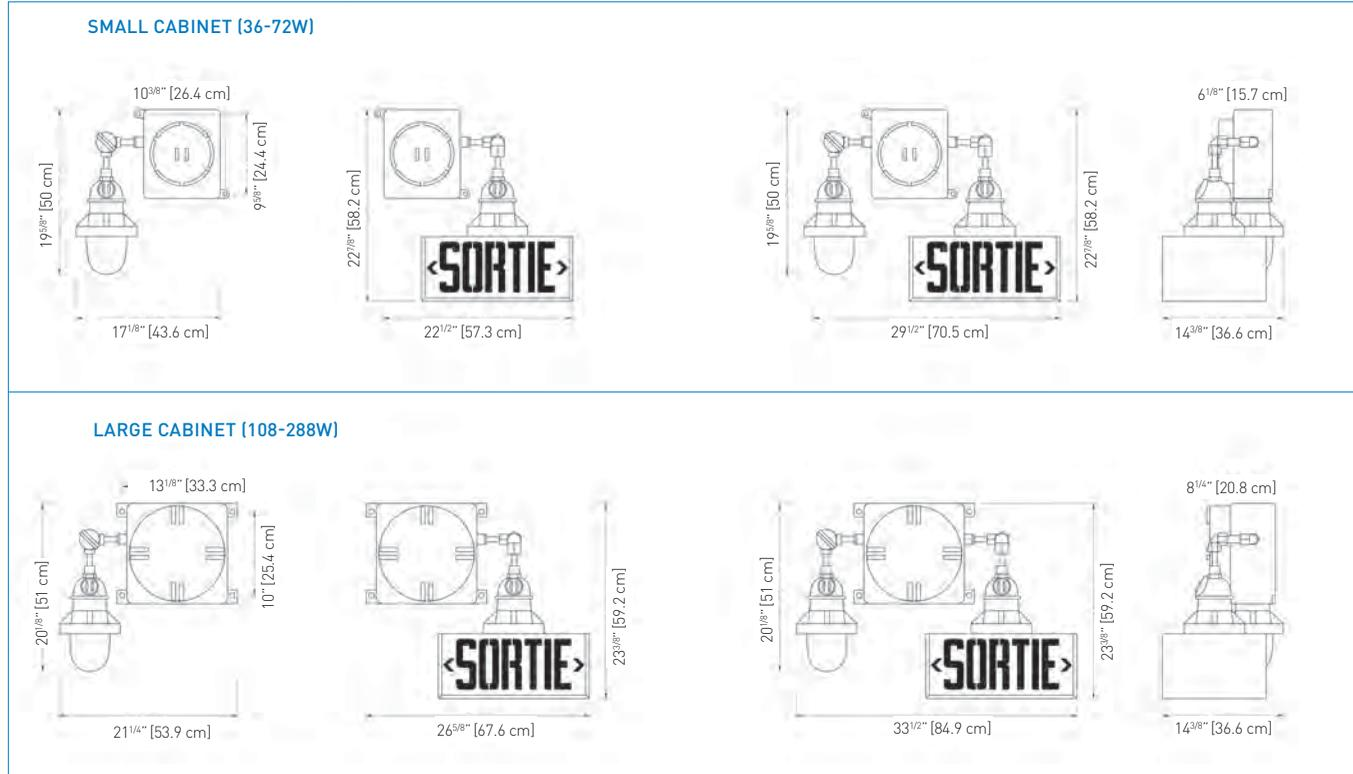

## ORDERING INFORMATION

Before ordering, identify the environment of your application: Class \_\_\_\_\_, Division \_\_\_\_\_, Group \_\_\_\_\_. Refer to table 1 for the Severity Code to use in your catalogue number. For temperature information, please see table 2.

### 3. EXP

VOLTAGE	SERIES	CAPACITY CABINET SIZE	AC VOLTAGE	OPTIONS	HEAD STYLE AND WATTAGE	SEVERITY CODE	LAMPS
6= 6V	EXP	36= 36W 72= 72W 108= 108W	Blank= 120VAC -2= 277VAC -3= 347VAC	Blank= no options D= time delay (15 minutes) S1= SORTIE single face, LED S2= SORTIE double face, LED TS= transfer switch	Blank= no heads /11= single remote, 1 lamp /12= single remote, 2 lamps /21= double remote, 1 lamp	S1= CL.I, Div.1, Gr. A, B S2= CL.I, Div.1, Gr. C, D S3= CL.I, Div.2, Gr. A, B, C, D S4= CL.II, Div.1, & 2 Gr.E, F, G CL.III, Div.1 & 2	12= halogen, 6V, 12V, 12W quartz bi-pin 20= halogen, 12V, 24V, 20W, quartz bi-pin
12= 12V		72= 72W 144= 144W 200= 200W					
24= 24V		144= 144W 288= 288W					

\*For temperature codes, consult your sales representative.

EXAMPLE: 06EXP36S112



# ET Series

Power-Free "Exit", "Sortie" or Pictogram Sign

Project/Location: \_\_\_\_\_

Contractor: \_\_\_\_\_

Date: \_\_\_\_\_

Prepared by: \_\_\_\_\_

## FEATURES

- Illumination provided by borosilicate glass tubes, internally coated with zinc sulphide phosphor and filled with tritium gas
- Minimum brightness at time of manufacture is 0.132 foot-lambert (0.452 cd/m<sup>2</sup>)
- Decorative, slim-line heavy-duty ABS housing
- Rugged, impact-resistant polycarbonate face
- Spark-free construction
- Simple installation – universal direction capability, comes complete with universal mounting hardware
- Stands up to extreme temperatures in outdoor or indoor applications
- Life expectancy of 10 or 20-year (EXIT), 12-year (SORTIE) and 10-year (PICTOGRAM)
- Available in single or double face
- ISO 9001 Certified for Pictogram Sign
- Pictogram Sign includes universal stencils (straight from here, left from here and right from here)

## TYPICAL SPECIFICATIONS

Supply and install **Emergi-Lite® EX160 (EXIT)** or **SR160 (SORTIE)** or **ET (PICTOGRAM)** Series Self-Luminous Exit Signs. The Exit Sign shall be constructed of a thermoplastic housing and be corrosion proof. The sealed housing will incorporate no loose or removable parts allowing for easy installation. The standard minimum guaranteed life will be 10 years. The standard mounting brackets will allow for either end/ceiling or wall mount. Standard "Exit" and "Sortie" Signs shall be supplied with white letters that are 6" high by 3/4" stroke. The initial average minimum brightness shall be 0.132 foot-lambert (0.452 cd/m<sup>2</sup>).

The equipment shall be **Emergi-Lite®** Model: \_\_\_\_\_ .

## WIRE GUARDS

460.0079-E	Wall Mount
460.0027-E	End Mount
460.0028-E	Ceiling Mount



## DIMENSIONS

Dimensions are approximate and subject to change.

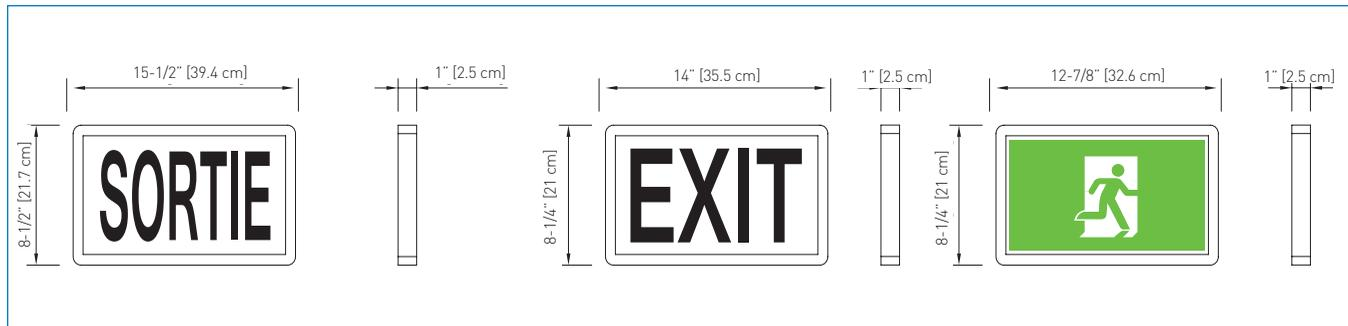

## ORDERING INFORMATION: EXIT OR SORTIE SIGN

SERIES	BACKGROUND COLOURS	HOUSING COLOURS	LIFE YEARS	OPTIONS	NEW
<b>EX162</b> = EXIT sign, single face, universal mount and chevrons <b>EX163</b> = EXIT sign, double face, universal mount and chevrons <b>SR162</b> = SORTIE sign, single face, universal mount and chevrons <b>SR163</b> = SORTIE sign, double face, universal mount and chevrons	<b>Blank</b> = red <b>G</b> = green*  * Not available in Sortie	<b>G</b> = grey* <b>W</b> = white* <b>B</b> = black  * Not available in Sortie	<b>-10</b> = 10 years (EXIT only) <b>-12</b> = 12 years (SORTIE only) <b>-20</b> = 20 years (EXIT only)*  * Per face.	<b>-AF</b> = aluminum frame* <b>-PC</b> = Polycarbonate shield* <b>-VR</b> = Vandal cover*  * Per face.	<b>-N</b>

EXAMPLE: EX162W-10-AF-N

## ORDERING INFORMATION: PICTOGRAM SIGN

SERIES	FACES	HOUSING COLOURS	LIFE YEARS	OPTIONS
<b>ET</b> = Pictogram Sign	<b>1</b> = single face universal mount and chevrons <b>2</b> = double face universal mount and chevrons	<b>W</b> = white <b>B</b> = black <b>G</b> = grey	<b>10</b> = 10 years*  * Standard	<b>AF</b> = aluminum frame* <b>PC</b> = Polycarbonate shield* <b>VR</b> = Vandal cover*  * Per face.

EXAMPLE: ET1W10AF

Unlike Exit or Sortie, the Pictogram Sign is not available in double arrow configuration.

Project/Location:

Contractor:

Date:

Prepared by:

# Special Wording

Illuminated Signage



## FEATURES

- The same sturdy construction and electrical design used in our Exit Signs is used to produce our custom-worded, illuminated signage
- Sign bodies - steel, extruded and Die-Cast aluminum, weatherproof, flame-retardant polycarbonate, high impact thermoplastic, recessed housing
- Also available with Self-Powered canopy and with emergency lamps
- Custom wording – any style of lettering, any language, any alphabet, any special characters
- Graphics – logos, standard symbols, custom art
- Colour choices – sign bodies, message, faceplate panel
- Illumination – LED (light-emitting diodes) – other light sources available - consult representative
- White-out, black-out and split picture options



## TYPICAL SPECIFICATIONS

Custom-worded, illuminated signage is available using the same sturdy construction and electrical design as **Emergi-Lite®** Exit Signage.

A wide range of sign body options and colour choices are available to suit any application.

Contact your local **Emergi-Lite®** sales representative to discuss your specific requirements.



WHITE-OUT OPTION	BLACK-OUT OPTION
 NON-ILLUMINATED	 NON-ILLUMINATED
 ILLUMINATED	 ILLUMINATED
When the sign is non-illuminated the acrylic panel in the faceplate appears blank white. The message appears only when the sign is illuminated.	When the sign is non-illuminated the acrylic panel in the faceplate appears black. The message appears only when the sign is illuminated.



# LED Retrofit Kits

Project/Location: \_\_\_\_\_

Contractor: \_\_\_\_\_

Date: \_\_\_\_\_

Prepared by: \_\_\_\_\_

## Convert high-consumption incandescent and fluorescent lamps to energy-efficient LED lamps

Converting existing Exit Signage from incandescent or fluorescent lamps to LED (light emitting diodes) lamps drastically reduces operating and maintenance costs for building owners and property managers. As part of energy-efficiency programs, some Canadian electric utilities are also actively promoting conversion to LED with incentive and rebate programs for installers and building owners/managers.

## FEATURES

**Emergi-Lite® offers four retrofit kit options; all based on the long-life ALINGAP LED technology:**

- SNAP II Series
- SNAP III Series
- SNAP I Series
- Bulb Series

### Benefits of using LED lamps in Exit Signs:

- Exceptional energy-efficiency – reduces energy consumption by up to 90%
- Extremely long life – 10 to 25 years
- Important reduction in maintenance and energy costs
- Average payback is less than two years (see page 6)
- Retrofit kits are easy to install
- Improved visibility and reliability: **ALINGAP** LED technology



## SNAP II SERIES

- Quick and easy to install
- Long-life, energy-efficient red **ALINGAP** LED technology
- Module features two independent circuits – one for AC input; one for DC input
- Universal AC input: 120/277/347VAC; universal two-wire DC input: 6 to 24VDC
- Power consumption of 1.1W per module
- 10 year limited warranty

## DIMENSIONS

Dimensions are approximate and subject to change.

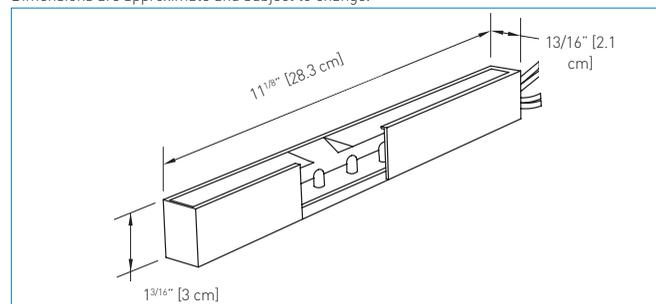

## POWER CONSUMPTION

MODEL	AC SPECS	DC SPECS
SNAP II	120/277/347VAC 1.1W	6 to 24VDC 1.3W

## ORDERING INFORMATION

SERIES	VOLTAGE
SNAP II= hardwire retrofit kit 11.0" (28cm) long	-UN= 120/277/347VAC, 6/12/24VDC -U36= 120/277/347VAC, 36VDC -U48= 120/277/347VAC, 48VDC -U120= 120/347VAC, 120VDC -120V-1H2= 120VAC, 120VDC, 2 wires
SNAP IIB= hardwire retrofit kit 9.5" (24cm) long*	

\*Available in UN voltage only.

EXAMPLE: SNAPII-UN

Project/Location:

Contractor:

Date:

Prepared by:

# LED Retrofit Kits



New Design:  
0.65W; 60% off power consumption.

## SNAP III SERIES

- Easiest to install in its class
- Compact size makes it ideal for virtually all Exit Signs
- Can be retrofitted directly on fluorescent ballast
- Long-life, energy-efficient red **ALINGAP** LED technology
- Available with AC adaptor for all types of lamp sockets
- 10 year limited warranty

## DIMENSIONS

Dimensions are approximate and subject to change.

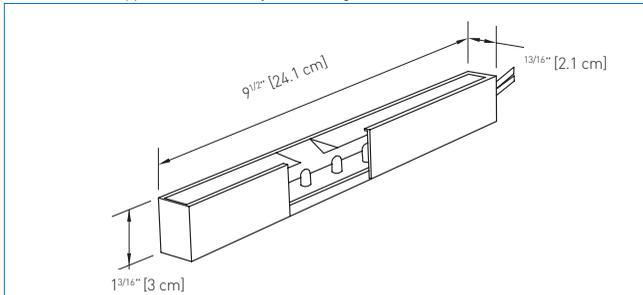

## POWER CONSUMPTION

MODEL	AC SPECS	DC SPECS
SNAP III	120VAC; 86VAC step down from 347VAC	0.65W N/A N/A

## ORDERING INFORMATION

SERIES	BASE
SNAP III= for standard applications	-C= candelabra -I= intermediate -M= medium -B= bayonet -F= G23 compact fluorescent -UN= complete set of bases (excludes "F" base) -H= 120VAC (hardwire) -2H= 277VAC (hardwire) -3H= 347VAC (hardwire)

EXAMPLE: SNAPIII-C



## SNAP I SERIES

- Easiest to install in its class
- Compact size makes it ideal for virtually all Exit Signs
- Can be retrofitted directly on fluorescent ballast
- Suitable for all AC line applications including Exit Signs equipped with in-line diodes
- Long-life, energy-efficient **ALINGAP** LED technology

## DIMENSIONS

Dimensions are approximate and subject to change.

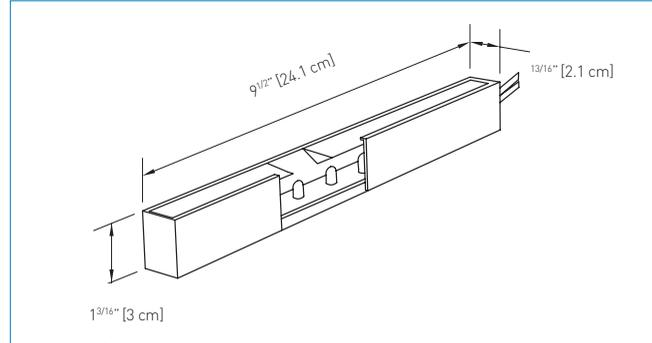

## POWER CONSUMPTION

MODEL	AC SPECS	DC SPECS
SNAP I	120VAC; 120VAC with in-line diodes	2.8W N/A N/A

## ORDERING INFORMATION

SERIES	BASE
SNAP I = with or without in-line diodes	-C= candelabra -I= intermediate -M= medium -B= bayonet -F= G23 compact fluorescent -UN= complete set of bases (excludes "F" base) -H= 120VAC (hardwire) -2H= 277VAC (hardwire) -3H= 347VAC (hardwire)

EXAMPLE: SNAP I-C



# LED Retrofit Kits

Project/Location:	_____
Contractor:	_____
Date:	_____
Prepared by:	_____



## BULB SERIES

- Quick and easy to install
- Available with a wide range of lamp bases for quick lamp to lamp replacement
- Long-life, energy-efficient **ALINGAP** LED technology
- 120VAC or 120VAC with in-line diode

## DIMENSIONS

Dimensions are approximate and subject to change.

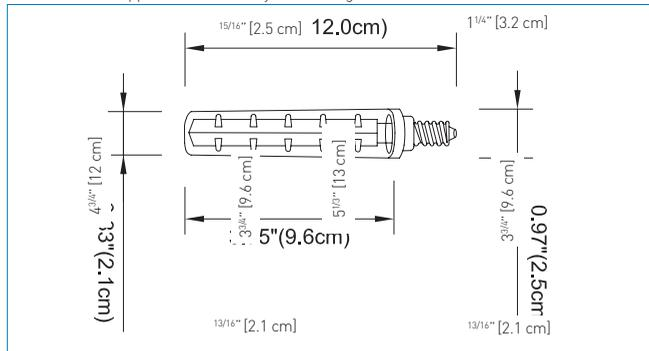

## POWER CONSUMPTION

MODEL	AC SPECS		DC SPECS	
	Voltage	Power	Voltage	Power
BULB I	120VAC	0.90W	N/A	N/A
BULB II	120VAC	2.6W	120VDC	2.6W

## ORDERING INFORMATION

SERIES	BASE
<b>BULBI/HB</b> = standard version <b>BULBII/HB</b> = with or without in-line diodes (2.5W), high brightness	<b>C</b> = candelabra <b>I</b> = intermediate <b>M</b> = medium <b>B</b> = bayonet <b>F</b> = G23 compact fluorescent

EXAMPLE: BULBI-C

## TYPICAL SPECIFICATIONS

The following is an example of the savings you can generate by simply installing an LED retrofit kit in an existing incandescent Exit Sign.

The Retrofit Kit Cost:	\$70.00
Installation cost (per unit) for a retrofit kit (Labour):	\$5.00
Wattage rating per incandescent lamp in existing fixture:	15W
Number of incandescent lamps per fixture:	2
Wattage rating of Emergi-Lite LMRUNIV retrofit kit:	1.7W
My existing incandescent exit lamps last for:	4 Months
My replacement labour cost:	\$25.00/Hour
Estimated lamp replacement time per exit:	20 Minutes
Current material cost for each Exit Sign lamp:	\$1.00/Lamp
My current energy cost:	\$0.060/\$ Per kWh
<b>THE PAYBACK FOR YOUR INSTALLATION IS:</b>	1.06 Years
<b>THE ANNUAL RETURN ON INVESTMENT IS:</b>	94.50 %
<b>ANNUAL SAVINGS:</b>	\$70.87

FOR MORE INFORMATION, PLEASE CONSULT YOUR SALES REPRESENTATIVE.

Project/Location: \_\_\_\_\_

Contractor: \_\_\_\_\_

Date: \_\_\_\_\_

Prepared by: \_\_\_\_\_

# Pendant Kit



## DIMENSIONS

Dimensions are approximate and subject to change.

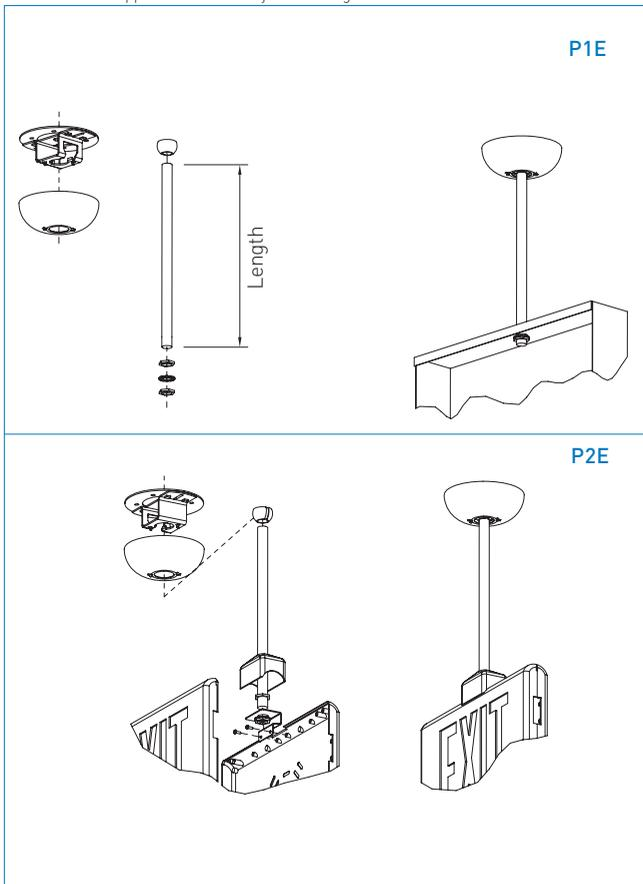

## TYPICAL SPECIFICATIONS

Offered in a variety of colours and lengths, **Emergi-Lite®** Pendant Kits are designed to facilitate the installation of Exit Signs at regular mounting heights.

Compatible with both horizontal and sloped ceilings, these Pendant Kits is truly universal and will adapt to any application.

Please consult your sales representative.

## ORDERING INFORMATION

SERIES	LENGTH (IN)	COLOUR
P1E*	6 12 18 24	W= white B= black SG= silver grey
P2E*	6 12 18 24	W= white B= black SG= silver grey
P23E* *Edge-Lit	6 12 18 24	W= white B= black SG= silver grey
P4E* *New Premier™ Plastic Exit	6 12 18 24	W= white B= black

\*Other lengths available on demand. Consult your sales representative.

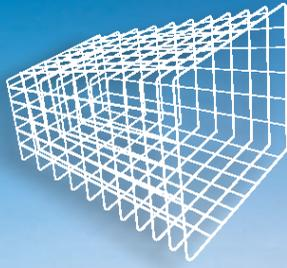

# Wire Guards

Project/Location: \_\_\_\_\_

Contractor: \_\_\_\_\_

Date: \_\_\_\_\_

Prepared by: \_\_\_\_\_

## EXIT SIGNS

PART #	MOUNTING	SIGNS		DIMENSIONS		
				W	H	D
460.0027-E	End Mount	LPEX100 LPEX50 LPEX600-N Series - Nema-4X Exit EX160 LPEX300	EX10 EN SR160 ES	10 1/2" (26.7 cm)	6" (15.2 cm)	16" (40.6 cm)
460.0028-E	Ceiling Mount	LPEX100 LPEX50 LPEX600 - Nema-4X EX160	LPEX300 EX10 EN SR160 ES	14 1/2" (36.8 cm)	6 1/4" (15.9 cm)	10 1/2" (26.5 cm)
460.0034-E	Wall Mount	12ESL-SR Sortie WP36	12ESL-EX C8SRPK-P	28 1/8" (71.5 cm)	21 1/8" (53.7 cm)	10" (25.4 cm)
460.0048-E	End Mount	LPSR100 C8SR50	LPSR300 C8SR10	10 1/2" (26.7 cm)	6" (15.2 cm)	21" (53.3 cm)
460.0057-E	Wall Mount	LPSR100 C8SR50	LPSR300 C8SR10	20 3/4" (52.7 cm)	10" (25.4 cm)	4" (10.2 cm)
460.0058-E	Ceiling Mount	LPSR100 C8SR50	LPSR300 C8SR10	21 3/4" (55.2 cm)	5 1/2" (14 cm)	10 1/2" (26.7 cm)
460.0059-E	Wall Mount	C8ES300 bilingual C8SE10	C8ES70 bilingual C8ES10	31" (86.4 cm)	10" (25.4 cm)	4 1/2" (11.4 cm)
460.0060-E	End Mount	LPEX600-N - Nema-4X Combo	EX10-P	20" (50.8 cm)	12" (30.5 cm)	15" (38.1 cm)
460.0060-E	Wall Mount	EN LPEX600-N Combo	EX10-P	20" (50.8 cm)	12" (30.5 cm)	15" (38.1 cm)
460.0078-E	Wall Mount	C8SR50-P Combo LPEX600-N - Nema-4X Combo	EX10-P ENC Premier™ Combo	18" (45.7 cm)	18" (45.7 cm)	7" (17.8 cm)
460.0079-E	Wall Mount	LPEX100 LPEX50 LPEX600 - Nema-4X EX160 LPEX300	EX10 Premier™ Exit EN ES SR160	14 1/4" (36.2 cm)	9 7/8" (25.0 cm)	4 5/8" (11.7 cm)
460.0080-E	Wall Mount	EXHZ combo (class1 Div2)	LPEXHZ Exit	15 1/4" (38.7 cm)	14 1/8" (35.9 cm)	6 1/2" (16.5 cm)
460.0081-E	Wall Mount	12ESL-EX, EAC, EX10-P, SR, ESC		20" (50.8 cm)	17 1/8" (43.6 cm)	8 1/2" (21.6 cm)
460.0091-E	Wall Mount	EX10-P		15" (38.1 cm)	10 1/2" (26.7 cm)	1" (2.5 cm)
460.0092-E	Ceiling Mount	C8SR10 C8ES300 Bilingual C8ES70	EX10-P C8ES70	31" (53.3 cm)	4.5" (11.4 cm)	10" (25.4 cm)
460.0103-E	Wall Mount	C8SRPK-P	C8E/S35R	25" (63.5 cm)	10" (25.4 cm)	20" (50.8 cm)
460.0104-E	End Mount	C8SR10				

Project/Location:

Contractor:

Date:

Prepared by:

# Wire Guards

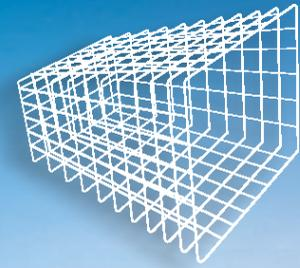

## BATTERY UNITS

PART	MOUNTING	COMMERCIAL, DECO UNIT	DIMENSIONS		
			W	H	D
460.0078-E	Wall Mount	"A" Cabinet-6V, 12V, 24V-Max. 144W	8" (45.7 cm)	8" (45.7 cm)	7" (17.8 cm)
460.0081-E	Wall Mount	"B" Cabinet-6V-180W 12V-200 to 360W 24V-200 to 288W	20" (50.8 cm)	17 1/8" (43.6 cm)	8 1/2" (21.6 cm)
460.0034-E 460.0097-E	Wall Mount	"C" Cabinet-12V-650watts 24V-350 to 720W Q-BIC	28 1/8" (71.5 cm)	21 1/8" (53.7 cm)	10" (25.4 cm)
			31" (53.3 cm)	70" (17.8 cm)	6" (15.2 cm)

## SMALL, 6V

460.0080-E	Wall Mount	6V, 12V - 18 to 72W	15 1/4" (38.7 cm)	14 1/8" (35.9 cm)	6 1/2" (16.5 cm)
------------	------------	---------------------	----------------------	----------------------	---------------------

## INDUSTRIAL

460.0082-E	Wall Mount	Small Cabinet	12" (30.5 cm)	9" (3.5 cm)	9" (3.5 cm)
460.0081-E		Medium and Large Cabinet	20" (50.8 cm)	17 1/8" (43.6 cm)	8 1/2" (21.6 cm)

## REMOTE HEADS

PART #	REMOTE HEADS	DIMENSIONS		
		W	H	D
460.0029-E	EF9, EF9Q, EF9M, EF11, EF25	8 1/4" (21.5 cm)	6 1/4" (15.9 cm)	6 3/4" (17.2 cm)
460.0031-E	EF26D, EF18T, EF11D	25 1/4" (64.1 cm)	8 1/2" (21.5 cm)	8 1/2" (21.5 cm)
460.0032-E	EF26DS, EF150	9 1/2" (24.1 cm)	9 1/2" (24.1 cm)	6 1/8" (15.6 cm)
460.0033-E	EF15	9 1/2" (24.1 cm)	9 1/2" (24.1 cm)	4" (10.2 cm)
460.0035-E	EF18, EF11, EF30, EF26, EF39, EF40	8 1/4" (21.5 cm)	6 1/4" (15.9 cm)	8 1/2" (21.5 cm)
460.0082-E	EF18D, EF11D, EF30D, Literay™, Lux-Ray™, Retract-a-Lite™	12" (30.5 cm)	9" (22.9 cm)	9" (22.9 cm)
460.0100-E	Provider™	14" (35.6 cm)	5.8" (14.7 cm)	5.6" (14.2 cm)

## MOUNTING SHELVES

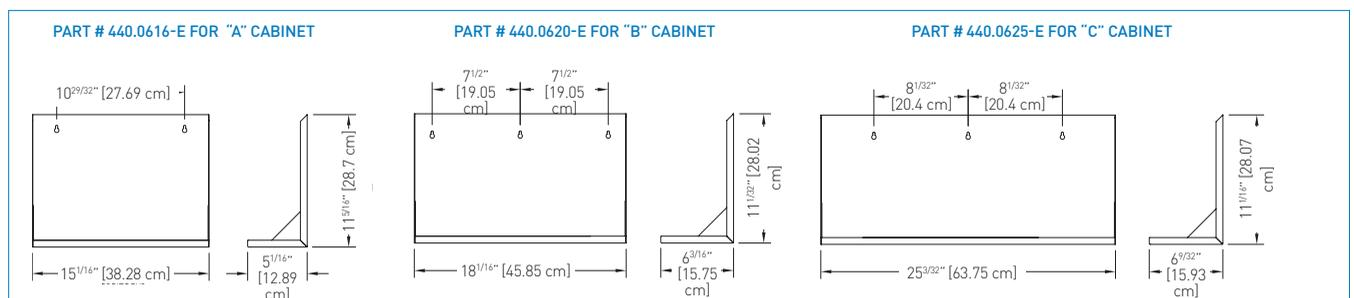

# EZ2™ Canopy

Quick and Easy Installation

Project/Location:

Contractor:

Date:

Prepared by:

## DIMENSIONS

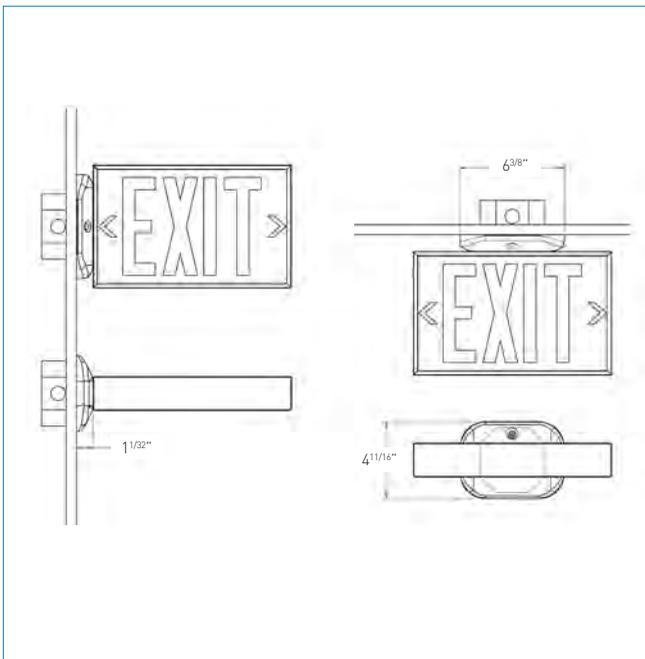

The **EZ2™ Canopy** allows the installer to make all of the electrical connections using both hands without having to juggle with the Exit Sign, making it our most contractor friendly product feature to date. Simply attach the backplate to the junction box, clip the canopy on the Exit Sign, hang the canopy on the back plate, make your connections using both hands, slide the unit in place, one screw and the job is done!

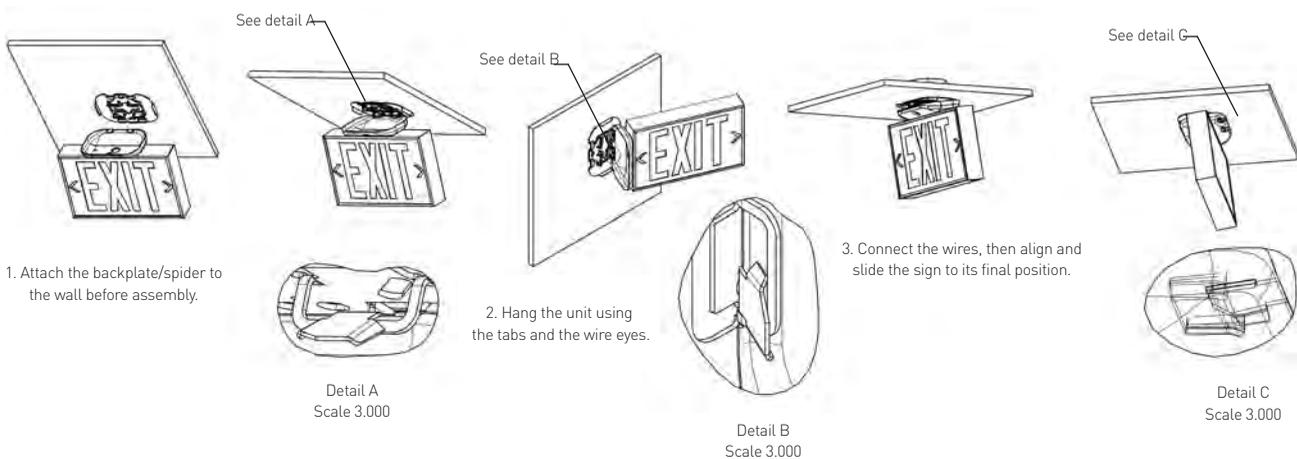

# GLOSSARY

<b>U</b>	Auto-diagnostic	Automatically tests and continuously monitors your emergency lighting unit. If a problem occurs, the unit will send a visual (flashing or blinking LED indicator) and audible warning. Complies with Fire Code requirements.
<b>UN</b>	Auto-diagnostic (non-audible)	Automatically tests and continuously monitors your emergency lighting unit. If a problem occurs, the unit will send a visual (flashing or blinking LED indicator) warning. Complies with Fire Code requirements.
<b>CT</b>	Cab-tire	Unit supplied with a cab-tire cable used for special hardwire applications.
<b>CW1</b>	Cold weather, 120VAC	120VAC input cold weather protection feature for applications where temperatures can reach -40° C.
<b>CW3</b>	Cold weather, 347VAC	347VAC input cold weather protection feature for applications where temperatures can reach -40° C.
<b>L</b>	Line cord (120V)	When ordering a battery unit with the LC option, we supply and pre-install a line cord with a standard 3 prong 120V plug. Just hang the fixture and plug it in to a standard receptacle! Only available on 120V units.
<b>FP</b>	Teflon coated lens	A protective teflon coating that is applied to the glass lens of a lighting fixture to prevent broken shards from falling in the event the glass is accidentally broken or vandalised.
<b>X2</b>	Remote test receiver	Used to perform maintenance tests by means of radio receiver in conjunction with a transmitter (HHC option) on battery units that are out of reach. Simply point the receiver at the unit.
<b>NEX</b>	NEXUS® system interface	The NEXUS® system interface is a computerized maintenance system for emergency lighting that, once programmed, will perform the tests, keep written records and send a notification if anything needs to be fixed. One full system can address hundreds of units in as many buildings as you need from a single location.
<b>D3</b>	Time delay (15 minutes)	Normally, when the AC power is restored, all emergency lighting lamps are turned off. However, in some cases, such as when metal halide lamps are used, it is possible that the general lighting will not be available for several minutes after the blackout (or brownout) period. Battery units with the D3 option will keep some energy in store to ensure that the emergency lighting stays on or comes back on for at least 15 minutes once the regular AC power has been restored.
<b>D</b>	Time delay (programmable)	Same as the D3 option but can be programmed for 5, 10 or 15 minutes delay.
<b>TP</b>	Tamper-proof screws	Screws that require a special bit. Can be used on certain units to deny access to unauthorized personnel.
<b>TL</b>	Twistlock plug	Used to facilitate the connection and removal of battery units for maintenance purposes.

LUX-RAY  
DISTINCTION

SURVIVE-ALL

SIPE  
RETRACT  
-A-LITE

JMLC  
ESLPK

JMLA  
ECLIPSE



# BATTERY UNITS

# TABLE OF CONTENTS

							
<b>INTRODUCTION</b>	<b>LUX-RAY LED SERIES</b>	<b>RETRACT-A-LITE SERIES</b>	<b>MINI RETRACT-A-LITE SERIES</b>	<b>PROVIDER SERIES</b>	<b>DISTINCTION RECESSED SERIES</b>	<b>DISTINCTION SERIES</b>	<b>DEL SERIES</b>
P. 96-97	P. 98-99	P. 100	P. 101	P. 102	P. 103	P. 104-105	P. 106-107
							
<b>ESLT SERIES</b>	<b>WONDERPACK WP36 SERIES</b>	<b>ECLIPSE SERIES</b>	<b>JMLC SERIES</b>	<b>JMLA SERIES</b>	<b>JEMP18 SERIES</b>	<b>PREMIER SERIES</b>	<b>ESL SERIES</b>
P. 108-109	P. 110	P. 111	P. 112-113	P. 114	P. 115	P. 116-117	P. 118-119
							
<b>SURVIVE-ALL™ NXM SERIES</b>	<b>IPE SERIES</b>	<b>SIPE SERIES</b>	<b>ESLPK SERIES</b>	<b>HZM SERIES</b>	<b>ESLNX SERIES</b>	<b>48 &amp; FPS SERIES</b>	<b>GLOSSARY</b>
P. 120-121	P. 122	P. 123	P. 124-125	P. 126-27	P. 128-129	P. 130	P. 131

# BATTERY UNITS OVERVIEW

## LIFE SAFETY EQUIPMENT

Emergency Lighting, as part of Life Safety Equipment, is one of the key elements to ensure public safety within buildings. In the event of failure of the normal power supply, self-powered units automatically provide the illumination required to evacuate the building in safe conditions.

## STANDARDS AND CODES

Requirements for the installation, level, and duration of emergency lighting in buildings are established by national standards: the National Building Code of Canada (CNBC-2005), the Canadian Electrical Code (CEC), and the National Fire Code of Canada (NFC-2005). Concerning the equipment, performance is established by the Canadian Standards Association (CSA), for example: C22.2 No.141, C860, etc.

## TYPES OF EMERGENCY LIGHTING

Emergency lighting equipment is divided in two main categories: self-powered emergency lighting equipment, also referred to as "unit equipment for emergency lighting", and central emergency power systems (separate emergency electrical power supply).

## SELF-POWERED (OR SELF-CONTAINED) EQUIPMENT

The most common self-powered unit consists of a 6V lead battery and two lamp heads, also referred to as emergency lights, each with a 6V, 9W incandescent lamp. Lamps are normally off; the storage battery has sufficient capacity to actuate and maintain the emergency lighting for at least 30 minutes in the event of a power failure. In some applications described in the National Building Code of Canada, the minimum emergency lighting period can reach 60 minutes or even 120 minutes. This will require battery units of a greater capacity. Once normal AC power supply is restored, heads turn off (if they were still on), the fixture recharges the batteries to full capacity within 24 hours, then returns to the stand-by mode.

## BATTERY UNITS AND REMOTE HEADS

There are also battery powered units that will supply power to several remote emergency lights of different wattages (12W, 20W, 50W, etc.). In this case, remote emergency lights (also referred to as remote heads) are installed in rooms and corridors, connected by wiring installed inside the walls. Some 6V self-contained fixtures can assume a total emergency lighting load up to 150W – 180W. At this level, the battery current (25A – 30A) begins to generate significant losses in the external wiring. For this reason, there are battery units of higher voltages, 12V and 24V, which can respectively supply power to remote heads totalling up to 360W and 720W.

## CENTRAL SYSTEMS

A higher wattage capacity emergency system is a Central System. In the event of a utility power failure, Central Systems continue to supply power to the emergency lighting equipment as well as other critical loads. A Central System that supplies power during a utility power failure is an emergency power system of which there are two types of Central Systems: the Direct Current Central System (DC System) and the Alternating Current Central System (AC inverter, UPS or Uninterruptible Power Supply/System). The electric power supplied by these systems can vary from a few KVAs to several hundred KVAs.

## INDUSTRIAL ENVIRONMENT

The industrial environment is the most severe in terms of housing construction requirements. It is defined by a number of parameters specific to various technical processes within the industry: temperature range, degree of humidity, degree of protection against water and dust, resistance to corrosive chemicals, presence of flammable gases and vapors or combustible particles, etc. An important performance factor is the degree of protection against solid particles (dust, etc.) and liquids. This rating is generally defined and measured as established by the American standard NEMA 250-2003 from the National Electrical Manufacturers Association, or, alternately, the European IP (ingress protection) code of the International Electrotechnical Commission (IEC 60529 standard). To accomplish the required degree of protection and resistance to corrosive agents, emergency lighting fixtures are designed/fabricated with gasketed, rugged, polycarbonate or fiberglass housings.

A special category exists covering hazardous areas, defined by technological processes generating (or susceptible to generate) flammable gases, vapors, flammable liquids or combustible dust particles in explosive concentrations in the atmosphere. Hydrogen or acetylene plants, gasoline and natural gas refineries, coal or magnesium mines, flour mills and textile factories are some examples. For more details on definitions and classifications of hazardous areas, consult the Canadian Electrical Code (CSA C22. 1-06).

Considering the risks of explosion or fire, all equipment dedicated to hazardous areas must meet, special standards such as: CSA C22.2 No. 30-M1986, No. 137-M1981, No. 213-M1987, etc. Based on each respective classification (Class, Division, Group), enclosures and remote heads for hazardous areas are fabricated of materials which must meet stringent requirements (pure forged aluminum, fiberglass, etc.) and may require specific components, such as seals, valves, gasketing, etc in addition to standards specific to emergency lighting. In view of all these additional specific characteristics, it can be expected that emergency lighting equipment approved for hazardous areas will cost more than fixtures classified for general industrial applications.

## EMERGENCY LIGHTING ENCLOSURES

Construction requirements for emergency lighting fixtures depends on the location where the equipment is to be installed. Of all the components, the enclosure (box or housing) is probably the most affected by the type of environment where it is located.

The enclosure plays many roles: it provides the fixture with a degree of protection against the environmental conditions, while meeting technical, aesthetic and functional requirements. Of course, cost can also be a deciding factor when selecting a fixture.

In general, non-residential lighting is divided in three market segments: commercial, institutional and industrial. This market segmentation still applies in the case of emergency lighting. Typically, the commercial and institutional sectors are more sensitive to costs and aesthetics, whereas the industrial sector is more influenced by the technical aspects (fixture durability, etc.).

## COMMERCIAL AND INSTITUTIONAL ENVIRONMENTS

Commercial spaces (stores, restaurants, theatres, hotels, etc.) as well as institutions are generally air conditioned, so the equipment operates in normal temperature and humidity conditions. Generally, the main selection criteria is total lighting costs, which include equipment and installation. The most economical design for self-contained units uses sheet metal housings of a neutral color: white or beige. For the most part, exit signs are housed in a rectangular box fabricated of steel (sheet metal) or extruded aluminum, and illuminated from a light source contained within the assembly (back-lit). Some molded plastic housings also exist (less expensive material, but also less rigid than metal) – mostly used for small battery units (lower wattages) and EXIT signs in provinces.

Even if aesthetics is a secondary criteria, manufacturers continue to develop products which offer a more contemporary look.

## AESTHETICS AND ARCHITECTURE

Fortunately, price isn't everything in the buying decision process. Some hotel chains, high-end stores and corporate headquarters are excellent examples.

In these situations, the architect and the lighting designer have a great influence in specifying emergency lighting fixtures. The question becomes – what will the architect prefer, a more decorative or a more unobtrusive, discreet look?

Battery units are becoming increasingly discreet.

The specifier can opt for a higher capacity unit (e.g.: 24V, 720W or a central DC System) installed in a hidden location, to supply power to remote heads distributed throughout the building. Another option would be to install recessed self-contained units concealed in the ceiling (T-bar), each with two lamp heads and additional capacity for remote heads. There are also single-lamp battery units (MR16 or PAR36) that can be recessed in the ceiling. As for remote heads, they are generally fabricated of forged aluminum and contain halogen MR16 lamps. It is also possible to conceal the battery units as well as the lamp heads entirely. For example, both the lamp heads and the housing of the PHANTOM self-contained unit are concealed in the wall or ceiling cavity, behind its door which rotates 180°. Upon power failure, an electromechanical device opens the door and exposes the emergency lamp heads to illuminate the path to safety. At the end of the power failure, this same device retracts the heads and closes the door.

To address specifiers' needs for aesthetics, manufacturers have developed new products for high end emergency lighting: dual-function decorative luminaires providing both normal lighting and emergency lighting. The lamps are powered by one of the two independent electrical circuits: AC circuit for normal lighting (including the wall switch), and an uninterrupted AC circuit for the battery charger and control of the emergency lighting. Since normal lighting levels are higher than those required for emergency lighting, manufacturers also offer the same type of luminaire for normal lighting only. This option provides the final user with the possibility of alternating self-contained units with standard lighting fixtures, while maintaining consistency of design.



# Lux-Ray™ LED Series

Rugged, Versatile, Sophisticated

Project/Location:	_____
Contractor:	_____
Date:	_____
Prepared by:	_____

## FEATURES

- Die-Cast aluminum housing, available in four finishes: dark bronze, off-white, black, and platinum gray
- NEMA-3R Rated for indoor/outdoor wet and damp locations: 0... 40°C
- Wall-mount installation on various junction boxes or via rigid conduit
- Patent-pending design for easy installation: wall-mount backplate includes electrical wire box with snap-on connector
- Patent-pending light engine: four power LEDs with redundant inter-connections and very wide beam
- Clear polycarbonate lens of reduced size (3" x 1.5"), shock-absorbent and UV-resistant
- Battery: high-temperature rated, Nickel-Metal Hydride technology
- Power consumption in stand-by: less than 5W
- Self-Test and diagnostic functions operated by micro-controller
- Certified to CSA 22.2 No.141-10 and No.250.0-08 standards
- 90 minutes run time

## OPTIONS

- Cold weather: (-40°C... 30°C)
- Forward-throw light distribution, for applications of outdoor exit discharge (OSHA 1910.36)
- High-lumen output: 25 to 50% additional level of illumination compared to standard models
- Dual-mode operation: normal lighting and/or emergency lighting with separate AC inputs
- Photo-switch: dusk-to-dawn control of normal lighting
- Remote test: infrared remote control (keyboard ordered separately)
- Time delay: 15 minutes

## IN THE SAME FAMILY



Luxray™ LED Remote Fixture

P.138

## TYPICAL SPECIFICATIONS

Supply and install the **Lux-Ray™ Series of LED** emergency lighting from **Emergi-Lite®**. The unit body shall include a back-plate and housing made of Die-Cast aluminum with paint finish color: \_\_\_\_\_ and a UV- and impact-resistant polycarbonate lens of reduced size: 3-in by 1.5-in. The back-plate shall have knockouts for wires and wall-mount installation box as well as a threaded hole for rigid conduit entry at the top of the unit. The back-plate shall have a built-in electrical box with wire terminals and snap-on connector. After complete electrical installation of the back-plate the equipment housing shall be installed by a simple push & snap over the back-plate.

The emergency lights shall be 4 (four) power light-emitting diodes (LED) with operational life of minimum 36,000 hours, maintaining at least 70% of the initial light level (reported L70). The LED lamps shall have redundant interconnections: eventual failure of one lamp shall allow other LED lamps to function. The unit shall have a dual-voltage input rated 120/347VAC, 60Hz. The battery charger shall include low voltage disconnect to prevent deep discharge, battery lockout to prevent battery drain prior to energizing the utility power, and brownout protection which will automatically switch the unit into emergency mode if the utility power falls below 80% of nominal level. The unit with Nickel-Metal Hydride battery shall be equipped with a micro-controller-based non-audible auto-test circuit and provide minimum 90 minutes of emergency lighting. The unit shall self-test for one minute every month, 30 minutes every six months and 90 minutes annually.

The pilot light shall be integrated with the test button; it shall be a bi-color LED and shall change color from normal green to flashing red when a failure is detected from the battery, charger circuit or lamps. A label located near the pilot light shall describe the diagnostic for each flashing code. When specified, models with dual-mode illumination shall include two separate AC input circuits: un-switched for emergency lighting and switched for normal lighting. When specified, models equipped with photo-switch shall automatically activate the normal lighting only from dusk till dawn, for additional energy savings. The typical ambient illumination for the photo-switch shall be 10 lux (to turn-on) and 30 lux (to turn-off).

When specified, the unit shall be controlled by an infrared remote control keypad (ordered separately). The remote control shall be able to simulate a power failure of 1 minute, 30 minutes or 90 minutes and also to cancel the test in progress at any time. For units with dual-mode lighting the remote keypad shall also control the normal lighting with on/off switch and dimming functions. The unit shall be certified to CSA 22.2 No.141-10 for minimum 90 minutes and No.250.0-08 standards.

The unit shall be **Emergi-Lite®** model: \_\_\_\_\_.



**NEMA-3R**



## POWER CONSUMPTION

MODEL TYPE	AC SPECS: 120/347VAC				6-12VDC REMOTE
	NORMAL LIGHTING		EMERGENCY LIGHTING		
	CURRENT (MAX)	POWER (MAX)	CURRENT (MAX)	POWER (MAX)	
ACSD, SD, SD-H	0.12/0.05 A	12W	0.05/0.02 A	5W	NiMH battery
SD-CW	-	-	0.16/0.06 A	16W	
ACSD-CWP, -CW-RC	n/r*		0.24/0.10 A	24W	

\*Note: Only unswitched AC input; normal lighting with photo-switch or remote control

Project/Location:

Contractor:

Date:

Prepared by:

# Lux-Ray™ LED Series

Rugged, Versatile, Sophisticated



**TABLE A: SPACING FOR AVERAGE 1FC/NATIONAL BUILDING CODE, CANADA**

MODEL TYPE	MOUNTING HEIGHT	WATTAGE CAPACITY	
		SINGLE	CENTRE-TO-CENTRE
Standard	9'	6' X 50'	6' X 50'
With option -H	11'	6' X 60'	6' X 60'
With option -FT	12'	6' X 40'	3' X 70'
With option -FTH	15'	6' X 50'	-

Indoor reflectance: 80/50/20 and 10-ft wide corridor.  
Outdoor reflectance: 0/30/10

Note: The illumination level meets ALL the requirements of the National Building Code-Canada and the Life Safety Code (NFPA 101):

- 1) Average of 1 foot-candle or more
- 2) Minimum at any point of 0.1 foot-candle or more
- 3) Maximum-to-minimum illumination uniformity ratio of 40:1 or less

**TABLE B: SPACING FOR MINIMUM 1FC MAX./MIN. UNIFORMITY RATIO LESS THAN 3:1**

MODEL TYPE	MOUNTING HEIGHT	WATTAGE CAPACITY	
		SINGLE	CENTRE-TO-CENTRE
Standard	9'	4' X 28'	4' X 32'
With option -H	11'	4' X 32'	4' X 40'
With option -FT	12'	4' X 22'	-
With option -FTH	15'	4' X 27'	-

**WIDE BEAM (STANDARD)**

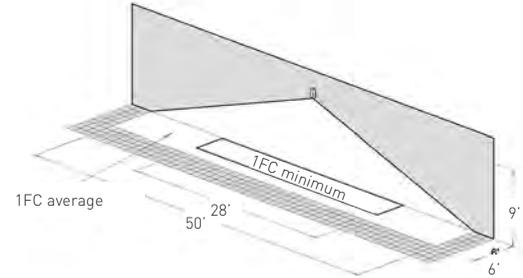

**FORWARD THROW (OPTIONAL)**

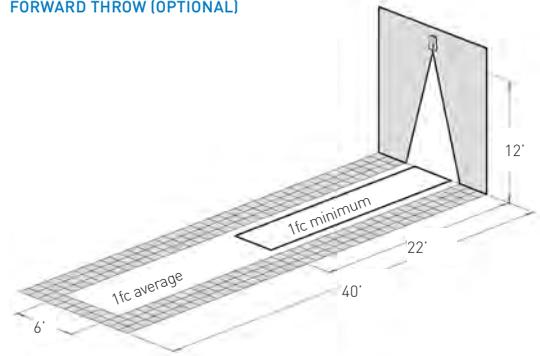

## DIMENSIONS

Dimensions are approximate and subject to change.

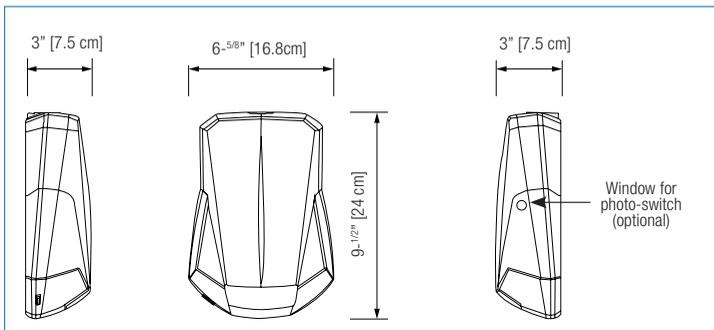

## REMOTE CONTROL

Patent Pending

EMERGENCY LIGHTING

NORMAL LIGHTING WITH SWITCH & DIMMING



PART#: TB-RC1-E

## ORDERING INFORMATION

SERIES	FUNCTION: BATTERY UNITS	COLOUR	OPTIONS
LUX= Lux-Ray™ LED	SD= Self-Powered & diagnostic (0... 50°C) ACSD= Dual-mode AC/Self-Powered & diagnostic (0... 40°C)	BK= black BZ= dark bronze OW= off white PG= platinum grey	-CW= Cold weather (-40°C... 30°C; not available with option -H) -FT= Forward throw lighting -H= High lumen output (max. 30°C; model SD only) -P= Photo-switch (model ACSD only) -RC= Remote control - infrared* -D3 = time delay (15 minutes) -2 = 277VAC 60Hz input

\* Remote control keypad (TB-RC1-E) ordered separately.

EXAMPLE: LUXACSDBZ-P



# Retract-a-Lite™ Series

100% Recessed Emergency Lighting

Project/Location: \_\_\_\_\_

Contractor: \_\_\_\_\_

Date: \_\_\_\_\_

Prepared by: \_\_\_\_\_

## FEATURES

- Door flips 180° when AC fails
- Fully automatic operation – brown-out sensitive transfer circuit automatically goes to emergency lighting mode and, when the power is restored or at the end of battery discharge, the motor turns the door back to its original closed mode (time delay option required).
- Customized finish – unit sold in white but can be painted or wallpapered on site to match existing décor
- Heavy-duty back-box – made of heavy-duty, galvanized steel
- High-performance lighting – includes two MR16 halogen lamps; power range from 2x12W up to 2x50W
- Patent-pending design
- Meets or exceeds CSA 22.2 No.141



## DIMENSIONS

Dimensions are approximate and subject to change.

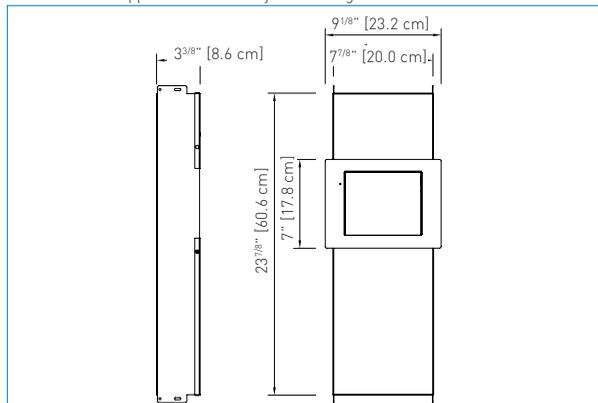

## REPLACEMENT LAMPS: MR16 TYPE

MODEL	LAMP TYPE	VOLTAGE/WATTAGE
580.0080-E	MR16 Halogen	12V-12W
580.0064-E	MR16 Halogen	12V-20W
580.0083-E	MR16 Halogen	12V-35W
580.0076-E	MR16 Halogen	12V-50W
580.0068-E	MR16 High-lumen output	12V-20W H
580.0090-E	MR16 High-lumen output	12V-35W H
580.0089-E	MR16 High-lumen output	12V-50W H
580.0093-E	MR16 LED	12V-4W
580.0104-E	MR16 LED	12V-5W
580.0106-E	MR16 LED	12V-6W

## ORDERING INFORMATION

SERIES	POWERPACK	VOLTAGE	NUMBER OF HEADS	OPTIONS
RTL	75= 12V-75W Lead-acid 150= 12V-150W Lead-acid	Blank= 120/347VAC -2= 120/277VAC	/12= MR16, 2x 12W /20= MR16, 2x 20W /35= MR16, 2x 35W /50= MR16, 2x 50W /20H= MR16, High lumen output, 2x 20W /35H= MR16, High lumen output, 2x 35W /50H= High lumen output, 2x 50W MR16 LG= MR16 LED, 12V-4W LI= MR16 LED, 12V-5W LJ= MR16 LED, 12V-6W	U= auto-diagnostics* UN= auto-diagnostics, non-audible* D3= time delay (15 minutes)  *Minimum lamp load required: 20% of unit capacity

EXAMPLE: RTL150/35HU

## TYPICAL SPECIFICATIONS

Supply and install **Emergi-Lite® Retract-a-Lite™ Series**. The unit shall be designed to be concealed in walls or ceilings with a cavity, including T-bar suspended ceilings. Bar hanger brackets shall be provided with the Self-Powered unit. The unit equipment shall come standard with a metal back box containing the batteries, the lamp assembly and a charging circuitry. The back box shall be constructed of heavy-duty galvanized steel. The unit components: battery assembly, charger circuitry and lamp assembly shall have a modular design and come standard with quick-connect plugs for easy installation in the back box. The unit equipment shall be completely concealed in the wall or ceiling during normal power conditions. Upon a power failure the unit will expose the emergency heads by rotating its door 180° and then power the lamps. At the restoration of the AC power or at the end of the battery discharge, the lamps will turn off and the unit will retract the heads in the wall (ceiling) by rotating the door by 180°. Under normal conditions, the only visible parts of the unit shall be the flat door and trim plate, coated with a high-quality off-white finish that can be customized on site with paint or other suitable wall covering. The light source shall be 12V MR16 halogen lamps of specified wattage and light output. The unit shall supply the rated load for a minimum of 30 minutes or until the battery is discharged to 87 1/2% of its nominal voltage (whichever duration is longer). The charger circuitry shall utilize a micro-controller IC that samples the battery in relation to the ambient temperature, state of charge, and input voltage fluctuations. The charger shall be current limited, temperature compensated, short-circuit proof, and reverse-polarity protected. The circuit will charge in accordance with CSA C22.2 – 141 requirements. The unit shall be furnished with a recessed, illuminated push button serving as test switch and status indicator light. When specified, the unit shall come complete with **Emergi-Lite®** auto-test micro-controller circuitry to ensure the equipment readiness and reliability by continuously monitoring every critical function of the unit. If a problem occurs, the pilot light located on the front of the unit will change color from green to red and will flash indicating a fault. A detailed diagnostic legend shall be available on the door back side and shall provide fault identification (battery, charger circuitry, lamps) for maintenance personnel. The auto-test shall simulate a power loss for one minute monthly, 10 minutes every 6 months, and a full 30-minute test every 12 months.

The equipment shall be **Emergi-Lite®** model: \_\_\_\_\_.

## POWER CONSUMPTION

MODEL	AC ASPECS		WATTAGE CAPACITY				
			30MIN	1H00	1H30	2H00	4H00
RTL75	120/347 VAC	0.25/0.09 A	75	40	30	24	15
RTL150			150	80	60	48	30

Project/Location:

Contractor:

Date:

Prepared by:

# Mini Retract-a-Lite™ Series

Unseen Solution the Next Generation



## FEATURES

- Easy to retrofit in finished walls: the unit slides in through an 8.25" by 5.75" hole
- No back-box needed to pre-install
- Input: Standard AC input 120/347VAC; optional 120/277VAC
- Output: 12VDC with up to 100W of power
- Battery: choice of sealed, maintenance-free Lead-Calcium or Nickel-Metal Hydride
- Remote capacity: can drive several wall or ceiling-mount 12VDC remote Retract-a-Lite™ fixtures
- Charger: micro-controller driven, temperature compensated, high precision, fast recharge
- Remote AC fixture: direct connection to 120 or 347VAC power generators
- MR16 halogen lamps; power range from 12W to 50W, LED 4W and 5W
- Certification: CSA C22.2 No.141



## DIMENSIONS

Dimensions are approximate and subject to change.

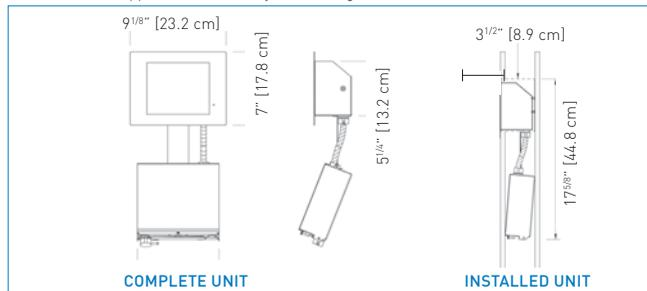

## REPLACEMENT LAMPS: MR16 TYPE

MODEL	LAMP TYPE	VOLTAGE/WATTAGE
580.0080-E	MR16 Halogen	12V-12W
580.0064-E	MR16 Halogen	12V-20W
580.0083-E	MR16 Halogen	12V-35W
580.0076-E	MR16 Halogen	12V-50W
580.0068-E	MR16 High-lumen output	12V-20W
580.0090-E	MR16 High-lumen output	12V-35W
580.0089-E	MR16 High-lumen output	12V-50W
580.0093-E	MR16 LED	12V-4W
580.0104-E	MR16 LED	12V-5W
580.0106-E	MR16 LED	12V-6W

## ORDERING INFORMATION

SERIES	POWERPACK	VOLTAGE	NUMBER OF HEADS	OPTIONS
MR	L80= Lead-Calcium, 12V-80W H100= Nickel-Metal Hydride, 12V-100W	Blank= 120/347VAC -2= 277VAC	/12= MR16, 2x 12W /20= MR16, 2x 20W /35= MR16, 2x 35W /50= MR16, 2x 50W /20H= MR16, High Lumen output, 2x 20W /35H= MR16, High Lumen output, 2x 35W /50H= MR16, High Lumen output, 2x 50W LJ= MR16 LED, 12V-5W LG= MR16 LED, 12V-4W LJ= MR16 LED, 12V-6W	U= auto-diagnostics* UN= auto-diagnostics, non-audible* D3= time delay (15 minutes)

\*Minimum lamp load required: 20% of unit capacity

EXAMPLE: MRL80/20HUN

## TYPICAL SPECIFICATIONS

Supply and install **Emergi-Lite® Mini Retract-a-Lite™ Series**. The unit shall be designed to be completely concealed in walls with a cavity. The equipment shall consist of a metal housing containing two modules joined by a flexible bracket and electric conduit. One module contains the battery, charger circuitry and electrical connection box; the other module contains the emergency lights installed on the back of a door able to rotate several turns of 360°. The unit equipment shall be completely concealed in the wall after installation through a rectangular opening not larger than 8.25" by 5.75". In stand-by mode, the only visible parts of the unit shall be the flat door and trim plate, coated with a high-quality off-white finish that can be customized on site with paint or other suitable wall covering. Upon a power failure the unit will expose the emergency heads by rotating its door 180° and then will power the lamps. At the restoration of the AC power or at the end of the battery discharge, the lamps will turn off and the unit will retract the heads by rotating the door 180° in the same direction. The unit shall not require the presence of AC power in order to close the door and conceal the lights. The door of the unit shall be easy to force-turn (open or close) by hand, in any rotation direction. The light source shall be 12V MR16 lamps of specified technology, wattage and light output. The unit shall supply the rated load for a minimum of 30 minutes or until the battery is discharged to 87.5% of its nominal voltage (whichever duration is longer). The charger circuitry shall utilize a micro-controller IC that samples the battery in relation to the ambient temperature, state of charge, and input voltage fluctuations. The charger shall be current limited, temperature compensated, short-circuit proof, and reverse-polarity protected. The circuit will charge in accordance with CSA C22.2 - 141 requirements. The unit shall be furnished with a recessed, illuminated push button serving as test switch and status indicator light. When specified, the unit shall come complete with the **Emergi-Lite®** series of auto-test micro-controller circuitry to ensure the equipment readiness and reliability by continuously monitoring every critical function of the unit. If a component failure occurs, the pilot light located on the front of the unit will change colour from green to red and will flash indicating a fault. A detailed diagnostic legend shall be available on the back side of the door and shall provide fault identification (battery, charger circuitry, lamps) for maintenance personnel. The auto-test shall simulate a power loss for one minute monthly, 10 minutes every 6 months, and a full 30-minute test every 12 months.

The equipment shall be **Emergi-Lite®** model: \_\_\_\_\_

## POWER CONSUMPTION AND UNIT RATING

MODEL	AC SPECS		WATTAGE CAPACITY			
			30MIN	1H00	2H00	3H00
MRL80	120/347VAC	-	80	40	24	-
MRH100	120/347VAC	0.25/0.08 A	100	70	36	24
MRG1	120VAC	Max. 0.95 A	Maximum 100W load			
MRG2	277VAC	Max. 0.45 A	Maximum 100W load			
MRG3	347VAC	Max. 0.35 A	Maximum 100W load			



# Provider™ Series

Project/Location:	_____
Contractor:	_____
Date:	_____
Prepared by:	_____

## FEATURES

- Injection-molded, impact-, scratch- and corrosion-resistant thermoplastic with a snap-together design
- Compact and versatile – unit measures only 11.75" x 5" and can be wall or ceiling mounted
- Variety of lamp types including optional MR16 LED lamps with life expectancy of 50,000+ hours
- Maintenance-free, long-life sealed Lead Calcium battery
- Fast and easy installation - AC quick connect plug, battery knockout feature.
- Fully automatic, solid-state charger with low voltage battery disconnect, brownout protection, integral test switch and long-life LED AC-On pilot lights
- Charger is temperature compensated and reverse polarity protected
- NEXUS® compatible (For more information, please consult your sales representative)
- Meets or exceeds CSA 22.2 No.141



## DIMENSIONS

Dimensions are approximate and subject to change.

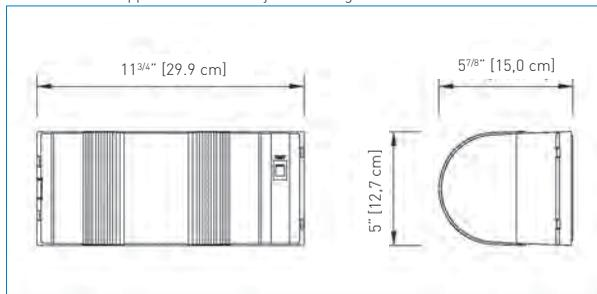

## TYPICAL SPECIFICATIONS

The contractor will install the **Emergi-Lite® Provider™ Series** battery unit. The emergency lighting system shall consist of fully automatic equipment with two (2) emergency lighting heads. The emergency lighting heads shall require no tools for adjusting or aiming. Each unit shall contain a fully automatic, solid-state charger with test switch and AC-on pilot lights. The unit shall contain a sealed transfer circuit and low-voltage disconnect circuit. The unit equipped with self-testing /self-diagnostic or Nexus® features shall automatically self-test for one minute every 30 days, 10 minutes in the 6th month and 30 minutes annually. When a fault is detected, the bi-colour pilot light shall turn from green to red and shall flash, identifying the source of the failure: battery, charger circuitry, lamp load.

The battery shall meet 6V with a capacity of 20 or 36W for 30 minutes. The unit shall be CSA C22.2 no 141.

The unit shall be **Emergi-Lite®** model: CPR0 \_\_\_\_\_ .

## WIRE GUARDS

460.0080-E	Wall Mount
------------	------------

## REPLACEMENT LAMPS

MODEL	LAMP TYPE	VOLTAGE/WATTAGE
570.0012-E	Mini tungsten, wedge base	6V-5.4W
580.0079-E	MR16 - Flood	6V-10W
580.0097-E	MR16 - LED	6V-4W

## POWER CONSUMPTION AND UNIT RATING

MODEL	AC SPECS		WATTAGE CAPACITY				
			30MIN	1H00	1H30	2H00	4H00
CPR0-1N	120/347VAC	0.07/0.03 A	20	15	12	8	-
CPR0-2N		0.08/0.03 A	36	21	15	12	6

## ORDERING INFORMATION

SERIES	COLOUR	INPUT VOLTAGE	UNIT TYPE	OPTIONS	LAMP TYPE
CPR0-1N= 6V, 20W CPR0-2N= 6V, 36W	Blank= factory white B= black	Blank= 120/347VAC 2= 120/277VAC	Blank= standard -U= auto-diagnostics -UN= auto-diagnostics, non-audible -NEX= NEXUS® system interface* -NEXRF= wireless NEXUS® system interface*	Blank= no options VR= vandal resistant screws L= 120VAC c/w line cord – supplied but not installed VM= voltmeter* CM= ceiling mount TP= tamper-proof screws** 690.0454= tamper-proof bit**  * Available with Standard unit type only ** One but per order	/LA= MR16 LED, 6V-4W /MJ= MR16, 6V-10W /ZP= mini tungsten, 6V-5.4W

EXAMPLE: CPR0-1N-NEXRFVR/LA

Project/Location: \_\_\_\_\_

Contractor: \_\_\_\_\_

Date: \_\_\_\_\_

Prepared by: \_\_\_\_\_

# Distinction™ Series

Decorative Recessed Fixture



## FEATURES

- Durable, powder-coated or electroplated Die-Cast aluminum construction
- High-performance MR16 halogen light source
- Maintenance-free, sealed Nickel Cadmium battery
- Quick disconnect feature for easy trim installation; easy to access for maintenance
- Fully automatic, solid-state Pulse-Guard charger with low voltage battery disconnect, brownout protection, integral test switch and long-life LED AC-On pilot lights
- Charger is designed for Nickel-Cadmium continuous trickle charge and is reverse polarity protected
- Recessed, directional, retractable trim
- Meets or exceeds CSA 22.2 No.141



## DIMENSIONS

Dimensions are approximate and subject to change.

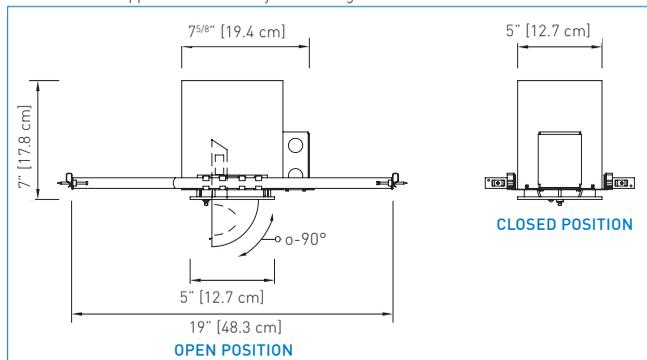

## TYPICAL SPECIFICATIONS

Recessed heads and housings: The contractor will supply and install **Emergi-Lite® Distinction™ Series** internally Self-Powered series. The unit will have a dual input 120/347VAC 60Hz. Recessed heads will be constructed of a durable powder coated, or electro plated Die-Cast aluminum construction and use MR16 halogen light sources and a 5 year Nickel-Cadmium battery.

The recessed head will be adjustable to 0-90° vertical and 0-350° horizontal angle. The light source will be 6V-6W, MR16 halogen narrow beam or otherwise specified. The unit shall be equipped with a sealed, high-temperature Nickel-Cadmium battery which will supply the emergency lamp for minimum 30 minutes of illumination in case of power failure.

The equipment shall be **Emergi-Lite®** Model: \_\_\_\_\_.

## REPLACEMENT LAMPS

ORDERING CODE	LAMP TYPE	VOLTAGE/WATTAGE
580.0074-E	MR16	6V-6W
580.0079-E	MR16	6V-10W

### IN THE SAME FAMILY



EFR Distinction™

P. 147

## POWER CONSUMPTION AND UNIT RATING

MODEL	AC SPECS		EMERGENCY POWER FOR LAMPS				
			30MIN	1H00	1H30	2H00	4H00
EFR2	120/347VAC	0.08/0.03 A	10	-	6	-	-

## ORDERING INFORMATION

SERIES	COLOUR	STANDARD	LAMP WATTAGE
EFR2	WH= white BK= black BN= brushed nickel CH= chrome PB= polished brass	SP-C= Self-Powered	Blank= MR16, 6W 10= MR16, 10W

EXAMPLE: EFR2WHSP-C



# Distinction™ Series

Decorative 6, 12 and 24V

Project/Location:	_____
Contractor:	_____
Date:	_____
Prepared by:	_____

## High performance and energy efficiency in a contemporary design.

The **Distinction™ Series** decorative battery units combine a contemporary design with the latest in high-tech security capability.

Designed to meet the needs of interior design professionals, these battery units are also high performance and energy-efficient.

### FEATURES

- Rugged steel cabinet with corrosion-resistant undercoating
- Removable front panel on cabinet provides easy access and allows unit to be mounted at ceiling height
- Solid-state pulse-type charger – current-limited, temperature-compensated
- Unit comes standard with electronic lockout and brownout circuits
- Sealed dust-proof transfer relay, test switch and LED indicator lights continuously monitor unit status
- Long-life, maintenance-free lead acid battery
- NEXUS® compatible (for more information on NEXUS®, please consult your sales representative)
- CSA C22.2 No. 141 certified



nexus®

## TYPICAL SPECIFICATIONS

Supply and install the **Emergi-Lite® Distinction™ Series** battery units.

The battery unit will supply the rated load for a minimum of \_\_\_\_\_ hour to 87.5% of the rated battery/voltage. The unit shall be rated 120 or 347V, 60 Hz and be CSA No.141 listed. The charger shall be fully computer tested and its charge voltage factory set to + or – 1% tolerance. A pulse type charger shall be employed to promote long battery life and reduce the potential for grid corrosion. The charger shall provide continuous high charge to recharge the battery. When the battery is at full capacity the charger will shut off. The pulse charge shall be current limited and precisely regulated by an electronic circuit which samples the battery in relation to its temperature, state of charge and input voltage fluctuations. The charger shall be current limited, temperature compensated, short-circuit proof and reverse polarity protected.

The unit shall be furnished with an electronic lockout circuit, which will connect the battery when the AC circuit is activated, and an electronic brownout circuit, which will activate the emergency lights when utility power dips below 75% of nominal voltage.

A low voltage battery protection circuit will disconnect the battery at end of the discharge. The unit will come complete with the **Distinction™ Series** diagnostics micro-controller board option. The unit shall self-test for 1 minute every 30 days, 10 minutes on the 6th month and 30 minutes every 12 months. The unit shall be furnished with a sealed dust tight relay, a selectable test switch 1 minute, 5 minutes, 10 minutes or 20 minutes and diagnostics LED indicator lights to continuously monitor the status of the unit: battery failed, battery disconnect, charger failure, lamp failure, service alarm, AC "ON" and charger "ON".

The unit shall be **Emergi-Lite®** model: \_\_\_\_\_.

## WIRE GUARDS

460.0078-E	Wall Mount	"A" Cabinet
460.0081-E	Wall Mount	"B" Cabinet
460.0034-E	Wall Mount	"C" Cabinet

## DIMENSIONS

Dimensions are approximate and subject to change.

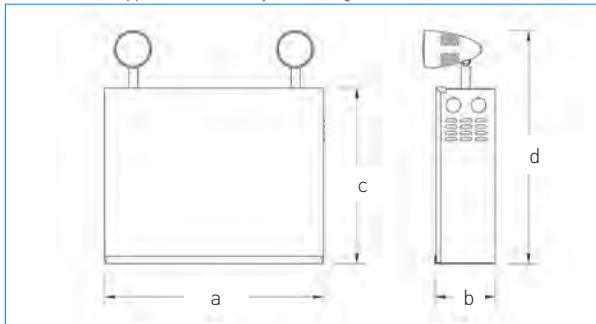

CABINET	DIMENSIONS			
	A	B	C	D
A	13 1/4" (33.7 cm)	3 5/8" (9.2 cm)	10 1/2" (26.7 cm)	14 1/4" (36.2 cm)
B	16 1/8" (40.9 cm)	5 1/2" (13.9 cm)	10 1/4" (26.0 cm)	13 7/8" (35.2 cm)
C	23 1/8" (58.7 cm)	5 1/2" (13.9 cm)	10 1/4" (26.0 cm)	13 7/8" (35.2 cm)

## REPLACEMENT LAMPS

ORDERING CODE	LAMP TYPE	VOLTAGE/ WATTAGE
570.0074-E	MR16, halogen	6V-6W
570.0079-E	MR16, halogen	6V-10W
570.0080-E	MR16, halogen	12V-12W
570.0093-E	MR16, LED	12V-4W
570.0098-E	MR16, LED	24V-4W
570.0097-E	MR16, LED	6V-4W
570.0104-E	MR16, LED	12V-5W
570.0106-E	MR16, LED	12V-6W

For the complete list, please see the lamp chart on pages 156 to 158

Project/Location: \_\_\_\_\_

Contractor: \_\_\_\_\_

Date: \_\_\_\_\_

Prepared by: \_\_\_\_\_

# Distinction™ Series

Decorative 6, 12 and 24V



## POWER CONSUMPTION AND UNIT RATING

MODEL	AC SPECS	WATTAGE CAPACITY					
		30MIN	1H00	1H30	2H00	4H00	
06ESL36	120/347VAC	0.10/0.04 A	36	21	15	12	6
06ESL72		0.22/0.08 A	72	42	30	24	12
06ESL108		0.22/0.08 A	108	63	45	36	18
06ESL180		0.22/0.08 A	180	105	75	60	30
12ESL72		0.15/0.06 A	72	42	30	24	12
12ESL100		0.34/0.12 A	100	58	42	33	17
12ESL144		0.40/0.14 A	144	84	60	48	17
12ESL216		0.41/0.14 A	216	84	60	48	24
12ESL250		0.41/0.14 A	220	120	90	72	36
12ESL360		0.43/0.15 A	250	144	100	83	42
24ESL144		0.55 / 0.20 A	360	300	210	170	80
24ESL200		0.67 / 0.23 A	200	117	83	67	33
24ESL288		0.67 / 0.23 A	208	168	120	96	48
24ESL350		0.67 / 0.23 A	350	200	144	120	60
24ESL432		0.67 / 0.23 A	432	250	180	144	72
24ESL550		0.88 / 0.33 A	550	320	230	180	90
24ESL720		0.88 / 0.33 A	720	600	420	340	160

\* Note: Units provide higher power for minimum one hour of emergency lighting.

## ORDERING INFORMATION

SERIES	CAPACITY	COLOUR	VOLTAGE	OPTIONS	# OF HEADS	HEAD STYLE	LAMP VOLTAGE-WATTAGE
06ESL= 6V	36= 36W (A) 72= 72W (A) 108= 108W (A) 180= 180W (B)	Blank= polar white BK= black	Blank= 120/347VAC input -2= 277VAC input	A= ammeter CT= cab-tire D= time delay (programmable) LW= cord and twist-lock plug (120V) P= light activated test switch T= lamp disconnect TB= DC terminal block TX2= remote test transmitter U= auto-diagnostics* UN= auto-diagnostics, non-audible* V= voltmeter X2= remote test receiver** NEX= NEXUS® system interface (for 6V and 12V units only)*** NEXRF= wireless NEXUS® system interface*** FB6= 6 cct. fuse panel TBACDC= AC/DC terminal block TBAC= AC terminal block	/1= one head /2= two heads /3= three heads	EF150= closed	MI= MR16, 6V-6W MJ= MR16, 6V-10W MK= MR16, 12V-12W MA= MR16, 12V-20W MB= MR16, 12V-35W MC= MR16, 12V-50W MS= MR16, 24V-12W MD= MR16, 24V-20W ME= MR16, 24V-35W MF= MR16, 24V-50W LA= MR16 LED, 6V-4W LG= MR16 LED, 12V-4W LL= MR16 LED, 24V-4W LI= MR16 LED, 12V-5W LJ= MR16 LED, 12V-6W
12ESL= 12V	72= 72W (A) 100= 100W (A) 144= 144W (A) 216= 216W (B) 250= 250W (B) 360= 360W (B)						
24ESL= 24V	144= 144W (A) 200= 200W (B) 288= 288W (B) 350= 350W (C) 432= 432W (C) 550= 550W (C) 720= 720W (C)						

\* Minimum lamp load required: 20% of unit capacity  
 \*\*One remote test receiver per order  
 \*\*\* Not all options available with the NEXUS® system. Please consult your sales representative.

EXAMPLE: 06ESL108U/2EF150MJ



# DEL Series

Decorative 6, 12 and 24V  
Thermoplastic Cube Units

Project/Location:	_____
Contractor:	_____
Date:	_____
Prepared by:	_____

## FEATURES

- Impact-resistant steel center cabinet contains the battery and charger
- Frosted, thermoplastic light cubes protect light modules against vandalism while providing visual masking and light diffusion
- Units can be wall or ceiling mounted
- Maintenance-free, sealed Lead-Calcium battery
- Fully automatic, solid-state charger with low voltage battery disconnect, brownout protection, integral test switch and LED AC-On pilot lights
- Also available as a remote fixture; see the Remote Fixtures section of this catalogue
- CSA C22.2 No. 141 certified
- NEXUS® compatible



## TYPICAL SPECIFICATIONS

Supply and install a complete emergency lighting system as described herein and shown on the drawings.

The **Emergi-Lite® DEL Smart Diagnostic** micro-controller board shall supply the rated load for a minimum of 1/2 hour to 87.5% of the rated battery voltage. The unit shall be rated 120V or 347V, 60 Hz and be CSA listed.

The unit shall have an output of \_\_\_\_\_ V.

The charger shall be fully computer tested and its charge voltage factory set to ± 1% tolerance. Chargers with field-adjusted potentiometers are not acceptable. A pulse-type charger shall be employed to promote long battery life and reduce the potential for grid corrosion. The charger shall provide a continuous high charge to recharge the battery, and when the battery is at full capacity, the charger will shut off. Periodically the charger shall provide a pulse of energy to keep the battery topped off. The charger shall be current limited, temperature compensated, short-circuit proof and reverse polarity protected. The unit shall be furnished with an electronic lockout circuit, which will connect the battery when the AC circuit is activated, and an electronic brownout circuit, which will activate the emergency heads when utility power dips below 75% of nominal voltage. A low voltage battery protection circuit shall be provided and will disconnect the battery from the fused output circuit at the end of discharge. The unit shall self-test for 1 minute every 30 days, 10 minutes every 6 months and 30 minutes every 12 months. The unit shall be capable of full recharge in compliance with CSA specifications. The unit shall be furnished with a sealed, dust-tight relay, a test switch and diagnostic LED indicator lights to continuously monitor the status of the unit: Battery Failure, Battery Disconnected, Charger Failure, Lamp Failure, Service Alarm, AC - "ON", Charger High Rate. The unit shall come complete with fully adjustable 12V or 24V/12W or 20W quartz halogen lamps. Each lamp shall be housed in an impact-resistant polycarbonate cube. The cube lens shall be frosted to diffuse light.

The unit shall be **Emergi-Lite®** model: \_\_\_\_\_.

## WIRE GUARDS

460.0097-E	Wall Mount or Ceiling Mount
------------	-----------------------------

## REPLACEMENT LAMPS

ORDERING CODE	TYPE	VOLTAGE/ WATTAGE
570.0016-E	Mini tungsten	6V-9W
570.0025-E	Mini tungsten	12V-9W
570.0045-E	Mini tungsten	24V-9W
580.0097-E	MR16, LED	6V-4W
580.0093-E	MR16, LED	12V-4W
580.0104-E	MR16, LED	12V-5W
580.0098-E	MR16, LED	24V-4W
580.0095-E	MR16, LED	120V-4W
580.0106-E	MR16, LED	120V-4W

For the complete list, please see the lamp chart on pages 156 to 158

### IN THE SAME FAMILY



### EF26/EF26DS/EF26D SERIES

P. 151

Project/Location:

Contractor:

Date:

Prepared by:

# DEL Series

Decorative, 6, 12 and 24V  
Thermoplastic Cube Units



## DIMENSIONS

Dimensions are approximate and subject to change.

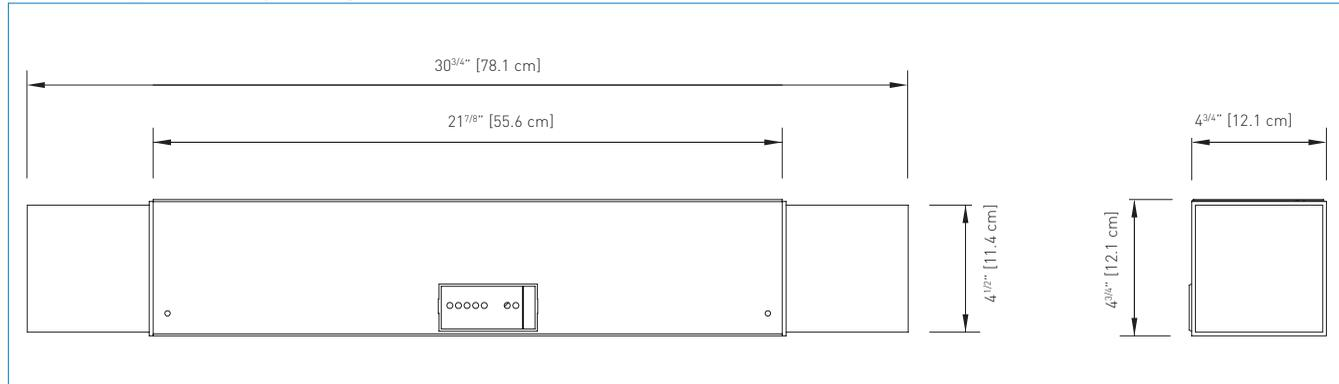

## POWER CONSUMPTION AND UNIT RATING

MODEL	AC SPECS	WATTAGE CAPACITY					
		30MIN	1H00	1H30	2H00	4H00	
06DEL36	120/347VAC	0.10/0.04 A	36	21	15	12	6
06DEL72		0.22/0.08 A	72	42	30	24	12
06DEL144		0.22/0.08 A	108	63	45	36	18
06DEL180		0.22/0.08 A	180	105	75	60	30
12DEL36		0.10/0.04 A	36	21	15	12	6
12DEL72		0.15/0.06 A	72	42	30	24	12
12DEL144		0.41/0.14 A	144	84	60	48	24
12DEL200		0.41/0.14 A	200	117	83	67	33
12DEL288		0.41/0.14 A	288	168	120	96	48
24DEL144		0.55/0.20 A	144	84	60	48	24
24DEL288		0.67/0.23 A	288	168	120	96	48

## ORDERING INFORMATION

SERIES	CAPACITY	VOLTAGE	OPTIONS	# OF LAMPS	LAMP STYLE/WATTAGE
06DEL= 6V	36= 36W 72= 72W 144= 144W 180= 180W	Blank= 120/347VAC input -2= 277VACinput	D= time delay L= line cord 120V LW= cord and twist-lock plug 120V T= lamp disconnect TB= DC terminal block TP= tamper-proof screws U= auto-diagnostics* UN= auto-diagnostics, non-audible* X2= remote test receiver** 690.0454-E= tamper-proof bit*** TX2= remote test transmitter NEX= NEXUS® system interface**** NEXRF= wireless NEXUS® system interface****  * Minimum lamp load required: 20% of unit capacity **Remote test transmitter needed. ***One bit per order. ****Not all options available with the Nexus® system. Please consult your sales representative.	/2= two lamps	Blank= tungsten, 6V, 12V, 24V-9W, wedge base -18= tungsten, 12V, 24V-18W, wedge base MI= MR16, 6V-6W MJ= MR16, 6V-10W MK= MR16, 12V-12W MA= MR16, 12V-20W MB= MR16, 12V-35W MC= MR16, 12V-50W MS= MR16, 24V-12W MD= MR16, 24V-20W ME= MR16, 24V-35W MF= MR16, 24V-50W Q= halogen, 6V, 12V-8W, quartz bi-pin Q12= halogen, 6V, 12V-12W, quartz bi-pin Q20= mini halogen, 6V, 12V, 24V-20W, quartz bi-pin LA= MR16 LED, 6V-4W LG= MR16 LED, 12V-4W LI= MR16 LED, 12V-5W LL= MR16 LED, 24V-4W LJ= MR16 LED, 12V-6W
12DEL= 12V	36= 36W 72= 72W 144= 144W 200= 200W 288= 288W				
24DEL= 24V	144= 144W 288= 288W				

EXAMPLE: 06DEL36U/2



# ESLT Series

6, 12, 24V T-Bar Unit

Project/Location:
Contractor:
Date:
Prepared by:

## Fully recessed units for T-Bar mounting in suspended ceilings.

The **ESLT Series** battery units are designed for T-bar ceiling grid installation. This slim-line, unobtrusive unit is ideally suited for any commercial location where there is limited wall space and where the greater directional flexibility of ceiling-mounted heads is needed to provide greater light distribution.

### FEATURES

- Rugged steel cabinet with corrosion-resistant undercoating.
- Battery and charger are concealed above the ceiling level in the unit cabinet
- Removable panel provides easy access to battery and circuitry
- Test switch and LED indicators are mounted on the visible bottom panel
- Units mount quickly and easily in standard 2' x 2' or 2' x 4' grids without any additional hardware
- Solid-state pulse-type charger – current-limited, temperature-compensated, short-circuit proof and reverse-polarity protected
- Unit comes standard with electronic lockout and brownout circuits
- Sealed dust-proof transfer relay, test switch and LED indicator lights
- Long-life, maintenance-free lead acid battery
- NEXUS® compatible (for more information on NEXUS®, please consult your sales representative)
- CSA C22.2 No. 141 certified



CABINET	DIMENSIONS					
	A	B	C	D	E	F
Large Cabinet	23 3/4" (60.3 cm)	7 1/4" (18.4 cm)	7 1/8" (18.1 cm)	10 5/8" (27.0 cm)	5 5/8" (14.3cm)	13" (33.0 cm)
Small Cabinet	23 3/4" (60.3 cm)	7 1/4" (18.4 cm)	4 5/8" (11.7 cm)	10 5/8" (27.0 cm)	3 1/4" (8.3 cm)	13" (33.0 cm)

### DIMENSIONS

Dimensions are approximate and subject to change.

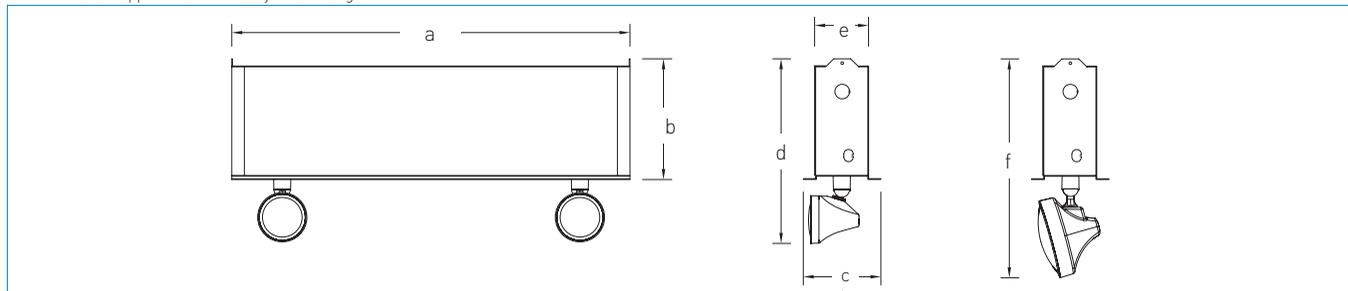

### TYPICAL SPECIFICATIONS

Supply and install a complete emergency lighting system as described herein and shown on the drawings.

The **Emergi-Lite® Smart Diagnostic** Micro controller board shall supply the rated load for a minimum of a 30 minutes to 87.5% of the rated battery voltage. The unit shall be rated 120V or 347V, 60 Hz and be CSA listed. The unit shall have an output of \_\_\_\_\_ V.

The charger shall be fully computer tested and its charge voltage factory set to ± 1% tolerance. Chargers with field-adjusted potentiometers are not acceptable. A pulse-type charger shall be employed to promote long battery life and reduce the potential for grid corrosion. The charger shall provide a continuous high charge to recharge the battery and when the battery is at full capacity, the charger will shut off. Periodically the charger shall provide a pulse of energy to keep the battery topped off. The charger shall be current limited, temperature compensated, short-circuit proof and reverse polarity protected. The unit shall be furnished with an electronic lockout circuit, which will connect the battery when the AC circuit is activated, and an electronic brownout circuit, which will activate the emergency lights when utility power dips below 75% of nominal voltage. A low voltage battery protection circuit shall be provided and will disconnect the battery from the fused output circuit at the end of discharge. The unit shall self-test for 1 minute every 30 days, 10 minutes every 6 months and 30 minutes every 12 months. The unit shall be capable of full recharge in compliance with a CSA specifications. The unit shall be furnished with a sealed dust tight relay, a test switch and seven diagnostic LED indicator lights to continuously monitor the status of the unit: Battery Failure, Battery Disconnected, Charger Failure, Lamp Failure, Service Alarm, AC "ON", Charger High Rate. The unit shall be T-bar mounted and come complete with tool-less emergency lighting heads requiring no tools to adjust or aim.

The unit shall be **Emergi-Lite®** model: \_\_\_\_\_ .

### REPLACEMENT LAMPS

ORDERING CODE	LAMP TYPE	VOLTAGE/WATTAGE
570.0016-E	Mini tungsten	6V-9W
570.0025-E	Mini tungsten	12V-9W
570.0045-E	Mini tungsten	24V-9W
580.0104-E	MR16, LED	12V-5W
580.0093-E	MR16, LED	12V-4W
580.00097-E	MR16, LED	6V-4W
580.00098-E	MR16, LED	24V-4W
580.0106-E	MR16, LED	12V-6W

For the complete list, please see the lamp chart on pages 156 to 158

Project/Location: \_\_\_\_\_

Contractor: \_\_\_\_\_

Date: \_\_\_\_\_

Prepared by: \_\_\_\_\_

# ESLT Series

6, 12, 24V T-Bar Unit



## POWER CONSUMPTION AND UNIT RATING

MODEL	AC SPECS	WATTAGE CAPACITY					
		30MIN	1H00	1H30	2H00	4H00	
06ESLT36	120/347VAC	0.10/0.04 A	36	21	15	12	6
06ESLT72		0.22/0.08 A	72	42	30	24	12
06ESLT108		0.22/0.08 A	108	63	45	36	18
06ESLT180		0.22/0.08 A	180	105	75	60	30
12ESLT36		0.09/0.03 A	36	21	15	12	6
12ESLT72		0.15/0.06 A	72	42	30	24	12
12ESLT100		0.34/0.12 A	100	58	42	33	17
12ESLT144		0.40/0.14 A	144	84	60	48	24
12ESLT216		0.41/0.14 A	200	117	83	67	33
24ESLT144		0.55/0.20 A	144	84	60	48	24
24ESLT288		0.67/0.23 A	288	168	120	96	48

## ORDERING INFORMATION

SERIES	CAPACITY	COLOUR	VOLTAGE	OPTIONS	# OF HEADS	HEAD STYLE LAMP WATTAGE
06ESLT= 6V	36= 36W 72= 72W 108= 108W 180= 180W	Blank= factory white BK= black	Blank= 120/347VAC input -2= 277VAC input	A= ammeter CT= cab-tire D= time delay LW= twist-lock plug T= lamp disconnect (programmable) FB6= 6 cct. fuse panel TBACDC= AC/DC terminal block TBAC= AC terminal block P= light activated test switch TB= DC terminal block TX2= remote test transmitter U= auto-diagnostics* UN= auto-diagnostics, non-audible* V= voltmeter X2= remote test receiver** NEX= NEXUS® system interface*** NEXRF= wireless NEXUS® system interface***	/0= no heads /1= one head /2= two heads /3= three heads	Blank= large tungsten, 6V, 12V, 24V-9W, wedge base -18= large tungsten, 12V, 24V-18W, wedge base -25= large tungsten, 6V, 12V, 24V-25W, DCB M= mini tungsten, 6V, 12V, 24V-9W, wedge base M18= mini tungsten, 12V, 24V-18W, wedge base MQ= mini halogen, 6V, 12V-8W, quartz bi-pin MQ12= mini halogen, 6V, 12V, 24V-12W, quartz bi-pin Q8= large halogen, 6V, 12V- 8W, quartz bi-pin Q12= large halogen, 6V, 12V-12W, quartz bi-pin Q20= large halogen, 6V, 12V, 24V-20W, quartz bi-pin Q55= large halogen, 12V-55W, quartz H3 Q70= large halogen 24V-70W, quartz H3 MI= MR16, 6V-6W MJ= MR16, 6V-10W MK= MR16, 12V-12W MA= MR16, 12V-20W MS= MR16, 24V-12W S= large tungsten, 6V, 12V-8W, sealed beam S18= large tungsten, 6V, 12V-18W, sealed beam S25= large tungsten, 6V, 12V-25W, sealed beam H= large halogen, 6V, 12V-8W, quartz sealed beam H12= large halogen, 6V, 12V-12W, quartz sealed beam H20= large halogen, 6V-20W, quartz sealed beam EF150MA= MR16 mini deco, 12V-20W* EF150MB= MR16 mini deco, 12V-35W* EF150MC= MR16 mini deco, 12V-50W* EF150MD= MR16 mini deco, 24V-20W* EF150ME= MR16 mini deco, 24V-35W* LA= MR16 LED, 6V-4W LG= MR16 LED, 12V-4W LI= MR16 LED, 12V-5W LL= MR16 LED, 24V-4W LJ= MR16 LED, 12V-6W EF150MF= MR16 mini-deco, 24V-50W EF150MS= MR16 mini-deco, 4V-12W
12ESLT= 12V	36= 36W 72= 72W 100= 100W 144= 144W 216= 216W					
24ESLT= 24V	144= 144W 288= 288W					

\* Minimum lamp load required: 20% of unit capacity  
 \*\*Remote test transmitter needed.  
 \*\*\* Not all options available with the NEXUS® system. Please consult your sales representative.

\*Aluminum head only

EXAMPLE: 06ESLT108U/2MQ



# WonderPack™ WP36 Series

Thermoplastic

Project/Location:
Contractor:
Date:
Prepared by:

## FEATURES

- Injection-molded thermoplastic housing
- Two adjustable glare-free light heads
- Test switch and charge rate indicators
- Emergency mode: min. 90 minutes
- Universal 120/347 VAC input
- CSA C22.2 No. 141 certified
- Innovative snap together design allows for fast installation



## TYPICAL SPECIFICATIONS

The Contractor will install the **Emergi-Lite® WonderPack™ WP36 Series** battery unit.

The emergency lighting system shall consist of fully automatic equipment with two MR16 glare-free halogen heads. Each unit shall contain a fully automatic, solid state charger with test switch and AC on pilot lights.

The unit shall contain a sealed transfer circuit and low voltage disconnect circuit. The battery shall be 6V with a capacity of 29W for 30 minutes.

The unit shall be CSA C22.2 no 141.

The unit shall be **Emergi-Lite®** model: \_\_\_\_\_.

## WIRE GUARDS

460.0100-E	Wall Mount or Ceiling Mount
------------	-----------------------------

## REPLACEMENT LAMPS

ORDERING CODE	LAMP TYPE	VOLTAGE/ WATTAGE
580.0072-E	MR16	6V-6W
580.0079-E	MR16	6V-10W

## DIMENSIONS

Dimensions are approximate and subject to change.

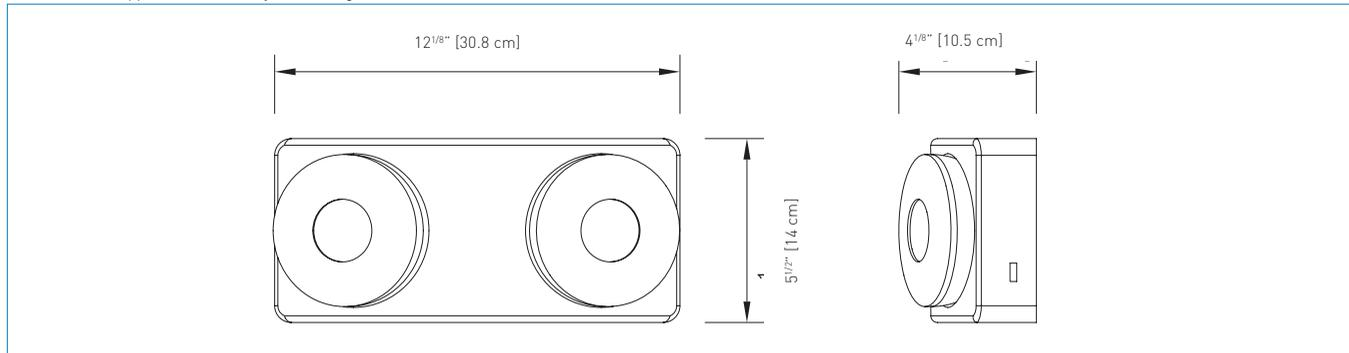

## POWER CONSUMPTION AND UNIT RATING

MODEL	AC SPECS			DC SPECS	
	VOLTAGE	CURRENT	POWER	VOLTAGE	MIN. RUN TIME
WP36/2M	120/347VAC	0.06/0.03 A	Less than 6W	6V-10.8W	Min. 90 minutes
WP36/2M10	120/347VAC	0.06/0.03 A	Less than 6W	6V-20W	Min. 30 minutes

## ORDERING INFORMATION

SERIES	CAPACITY	VOLTAGE	# OF LAMPS AND TYPE	OPTION
WP	36= 6V-29W	Blank= 120/347VAC	/2M= two MR16 lamps, 6V-5.4W (standard)	Blank= no options 10= MR16 lamps, 10W

EXAMPLE: WP36/2M10

Project/Location: \_\_\_\_\_

Contractor: \_\_\_\_\_

Date: \_\_\_\_\_

Prepared by: \_\_\_\_\_

# Eclipse™ Series

Rapid Installation  
Decorative Thermoplastic



## FEATURES

- Impact-resistant thermoplastic construction
- Wall or ceiling mount
- Pre-wired AC quick-connect plug for fast and easy installation
- Dual-voltage input: 120/347 VAC
- Two wedge-base, incandescent lamps of 6V- 5.4W
- DC-remote fused output of 6V-18W
- Fully automatic, solid-state battery charger with brownout protection, low-voltage battery disconnect, manual test switch and LED pilot light
- Maintenance-free, sealed Lead-Calcium battery with life expectancy of five years
- Listed CSA C22.2 No.141



## TYPICAL SPECIFICATIONS

Supply and install the **Emergi-Lite® Eclipse™ Series** battery unit. The unit shall come standard with housing and back plate of white thermoplastic and two prismatic-shaped lenses made of clear polycarbonate. The unit shall contain a fully automatic, solid-state charger circuit with test switch button and AC-on LED pilot light. The charger shall include features like brownout detection, low-battery disconnect and instant transfer.

The unit shall be equipped with two incandescent emergency lamps of 6V-5.4W and a maintenance-free Lead-Calcium battery with five-year life expectancy.

The total output for emergency lighting shall be 6V-29W for minimum 30 minutes.

The unit shall come standard with a DC-remote cable with in-line fuse and provide 18W of remote capacity.

The unit shall be listed CSA C22.2 no.141

The unit shall be **Emergi-Lite®** model: \_\_\_\_\_.

## REPLACEMENT LAMPS

ORDERING CODE	LAMP TYPE	VOLTAGE/ WATTAGE
570.0012-E	Tungsten, wedge base	6V-5.4W

For the complete list, please see the lamp chart on pages 144 to 146

## WIRE GUARDS

460.0100-E	Wall Mount or Ceiling Mount
------------	-----------------------------

## DIMENSIONS

Dimensions are approximate and subject to change.

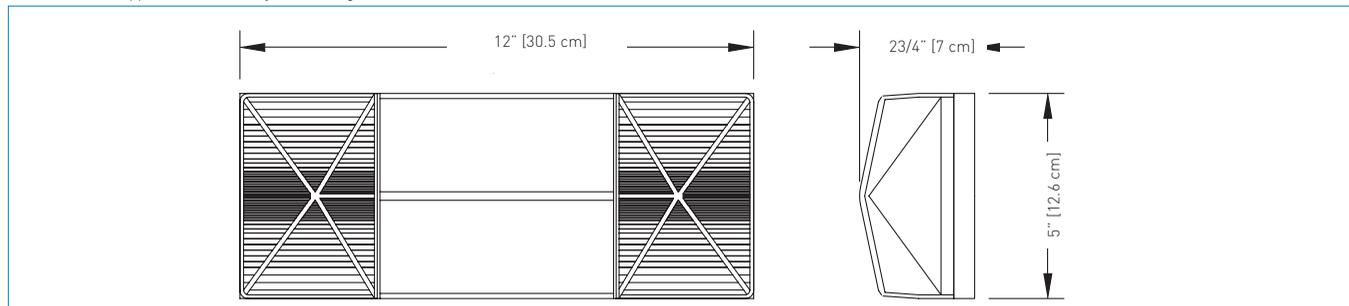

## POWER CONSUMPTION AND UNIT RATING

MODEL	AC SPECS		WATTAGE CAPACITY				
			30MIN	1H00	1H30	2H00	4H00
ECL-2	120/347VAC	0.06/0.02 A	29W	17W	12W	10W	-

## ORDERING INFORMATION

SERIES	UNIT CAPACITY	VOLTAGE	OPTIONS
ECL	-2V= 6V-29W	Blank= 120/347VAC	Blank= no options L= line cord (120V only)

EXAMPLE: ECL-2V



# JMLC Series

Steel, compact, 6V and 12V

Project/Location:
Contractor:
Date:
Prepared by:

## FEATURES

- Compact steel cabinet with corrosion-resistant undercoating
- Quick and easy installation – pre-assembled cordset, no batteries or board to remove before installation
- Universal Spider knockout pattern for junction box mounting
- Fully automatic solid-state charger with test switch and AC-on pilot light
- Sealed dust-proof transfer relay circuit and low-voltage disconnect
- Long-life, maintenance-free sealed
- NEXUS® compatible. Please consult your sales representative
- Heads require no tools for orientation
- Standard input 120 VAC with line cord installed
- 120/347 VAC without line cord
- Certified CSA C22.2 No.141



nexus®

## TYPICAL SPECIFICATIONS

The contractor shall install the **Emergi-Lite® JMLC Series** battery units. The emergency lighting system shall consist of fully automatic equipment with two emergency lighting heads. The unit shall be rated \_\_\_\_ V with a capacity of \_\_\_\_ W for 30 minutes of emergency operation.

The charger shall be factory set with a charging voltage tolerance of ± 1% to enable a longer battery life. The emergency light heads shall require no tools for adjusting or aiming. The metal cabinet shall be made of steel with anti-corrosion undercoating.

The unit equipped with the auto-test micro-controller board shall self-test 1 minute every 30 days, 10 minutes every 6 months and 30 minutes every 12 months. The unit shall be supplied with a test switch and diagnostic LED indicator lights to continuously monitor the status of the unit: Battery Failure, Battery Disconnect, Charger Failure, Lamp Failure, Service Alarm, main voltage AC "ON", Charger High Rate.

The unit shall be CSA Certified to C22.2 no.141.

The unit shall be **Emergi-Lite®** model: \_\_\_\_\_ .

## WIRE GUARDS

460.0080-E	Wall Mount
------------	------------

## POWER CONSUMPTION AND UNIT RATING

MODEL	AC SPECS		WATTAGE CAPACITY				
			30MIN	1H00	1H30	2H00	4H00
06JMLC27	120/347 VAC	0.06/0.02 A	27	15	11	9	-
06JMLC44		0.18/0.06 A	44	26	18	15	7
06JMLC72		0.19/0.07 A	72	42	30	24	12
12JMLC44		0.31/0.10 A	44	26	18	15	7
12JMLC72		0.31/0.10 A	72	42	30	24	12

## REPLACEMENT LAMPS

ORDERING CODE	LAMP TYPE	VOLTAGE/ WATTAGE
570.0012-E	Mini tungsten	6V-9W
570.0025-E	Mini tungsten	12V-9W
580.0097-E	MR16, LED	6V-4W
580.0093-E	MR16, LED	12V-4W
580.0104-E	MR16, LED	12V-5W
580.0106-E	MR16, LED	12V-6W

For the complete list, please see the lamp chart on pages 156 to 158

Project/Location: \_\_\_\_\_

Contractor: \_\_\_\_\_

Date: \_\_\_\_\_

Prepared by: \_\_\_\_\_

# JMLC Series

Steel, compact, 6V and 12V



## DIMENSIONS

Dimensions are approximate and subject to change.

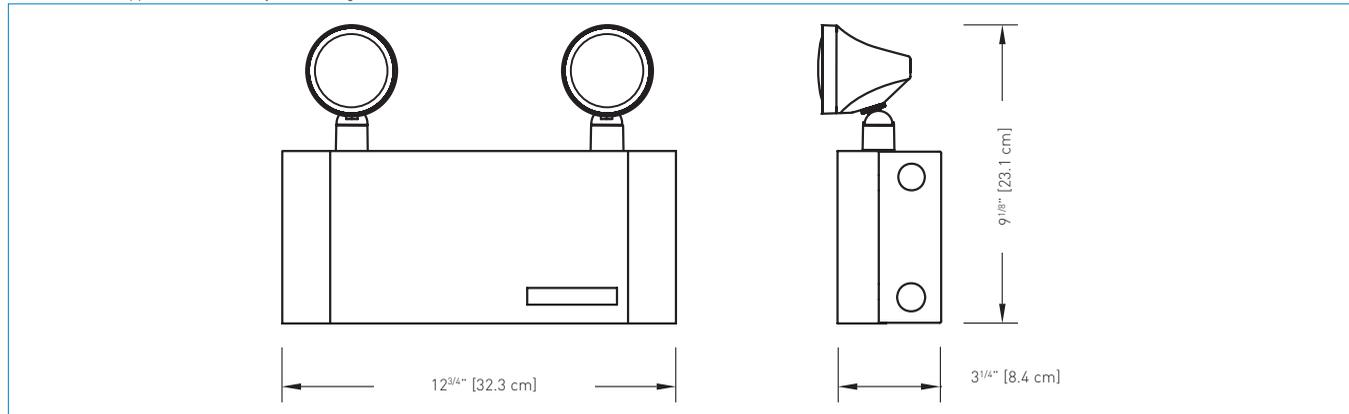

## ORDERING INFORMATION

SERIES	CAPACITY	COLOUR	VOLTAGE	OPTIONS	# OF HEADS	HEADS STYLE/WATTAGE
06JMLC = 6V	27= 27W* 44= 44W 72= 72W	Blank= factory white BK= black	Blank= 120VAC c/w linecord -2= 277VAC input -3= 120/347VAC input	Blank= no options CT= cab-tire LW= twist-lock plug U= auto-diagnostics* UN= auto-diagnostics, non-audible* NEX= NEXUS® system interface** NEXRF= wireless NEXUS® system interface**	/0= no heads /1= one head /2= two heads	Blank= large tungsten, 6V, 12V-9W, wedge base -18= large tungsten, 12V-18W, wedge base -25= large tungsten, 6V, 12V-25W, DCB H= large halogen, 6V, 12V-8W, quartz sealed beam H12= large halogen, 6V, 12V-12W, quartz sealed beam H20= large halogen, 6V-20W, quartz sealed beam M= mini tungsten, 6V, 12V-9W, wedge base M18= mini tungsten, 12V-18W, wedge base MQ= mini halogen, 6V, 12V-8W, quartz bi-pin MQ12= mini halogen, 6V, 12V, 24V-12W, quartz bi-pin MI= MR16, 6V-6W MJ= MR16, 6V-10W MK= MR16, 12V-12W MA= MR16, 12V-20W Q= large halogen, 6V, 12V-8W, quartz bi-pin Q12= large halogen, 6V, 12V-12W, quartz bi-pin Q20= large halogen, 6V, 12V, 24V-20W, quartz bi-pin S= large tungsten, 6V, 12V-9W, sealed beam S18= large tungsten, 6V, 12V-18W, sealed beam S25= large tungsten, 6V, 12V-25W, sealed beam LA= MR16 LED, 6V-4W LG= MR16 LED, 12V-4W LI= MR16 LED, 12V-5W LJ= MR16 LED, 12V-6W
12JMLC= 12V	44= 44W 72= 72W					

\*6V-72W available in ESL series only.  
\*\*Consult your sales representative - not available in 6V-72W.

EXAMPLE: 06JMLC44/2M



# JMLA Series

Decorative, 6 and 12V

Project/Location: \_\_\_\_\_

Contractor: \_\_\_\_\_

Date: \_\_\_\_\_

Prepared by: \_\_\_\_\_

## FEATURES

- Rugged steel cabinet with corrosion-resistant undercoating
- Removable front panel on cabinet provides easy access and allows unit to be mounted at ceiling height
- Solid-state pulse-type charger – current-limited, temperature-compensated, short-circuit proof and reverse-polarity protected
- Unit comes standard with electronic lockout and brownout circuits
- Sealed dust-proof transfer relay, test switch and LED indicator light(s)
- Long-life, maintenance-free lead acid battery
- NEXUS® compatible. Please consult your sales representative
- CSA C22.2 No. 141 Certified



nexus®

## DIMENSIONS

Dimensions are approximate and subject to change.

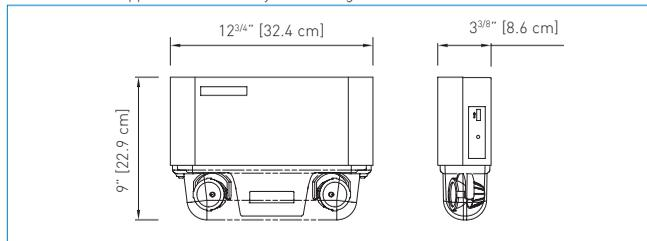

## WIRE GUARDS

460.0080-E	Wall Mount
------------	------------

## POWER CONSUMPTION AND UNIT RATING

MODEL	AC SPECS	WATTAGE CAPACITY					
		30MIN	1H00	1H30	2H00	4H00	
06JMLA27	120/347VAC	0.06/0.02 A	27	15	11	9	-
06JMLA44		0.18/0.06 A	44	26	18	15	7
06JMLA72		0.19/0.07 A	72	42	30	24	12
12JMLA44		0.31/0.10 A	44	26	18	15	7
12JMLA72		0.31/0.10 A	72	42	30	24	12

## ORDERING INFORMATION

SERIES	CAPACITY	COLOUR	VOLTAGE	OPTIONS	# OF HEADS	HEADS STYLE/WATTAGE
06JMLA= 6V	27= 27W* 44= 44W 72= 72W	Blank= factory white BK= black	Blank= 120/347VAC -2= 277VAC input	Blank= no options CT= cab-tire LC= linecord (120V) LW= twist-lock plug U= auto-diagnostics* UN= auto-diagnostics, non-audible* NEX= NEXUS® system interface** NEXRF= wireless NEXUS® system interface** * Minimum lamp load required: 20% of unit capacity ** Consult your sales representative, not available in 6V-72W. 6V-72W available in ESL	/2= 2 heads	LA= MR16 LED, 6V-4W LG= MR16 LED, 12V-4W LI= MR16 LED, 12V-5W LJ= MR16 LED, 12V-6W MI= MR16, 6V-6W MJ= MR16, 6V-10W MK= MR16, 12V-12W MW= MR16-IR, 12V-20W
12JMLA= 12V	44= 44W 72= 72W					

EXAMPLE: 12JMLA44UN/2MW

## TYPICAL SPECIFICATIONS

Supply and install the **Emergi-Lite® JMLA Series** battery units. The battery unit shall come complete with two MR16 emergency lighting heads. The unit shall be rated for dual voltage 120/347V, 60 Hz and shall provide power to the nominal load for at least 30 minutes to 87.5% of the nominal voltage of the battery. The charger shall be factory set with a charging voltage tolerance of ±1% to enable a longer battery life. The emergency light heads shall be fully adjustable and protected by a clear cover, made of shock-resistant polycarbonate. The protective cover shall be designed to facilitate lamp replacement. The heads shall be installed at the bottom of the unit, providing illumination in any downward direction. The emergency light heads shall require no tools for orientation. The unit cabinet shall be made of steel with anti-corrosion undercoating. The unit equipped with the auto-test diagnostic micro-controller board shall self-test 1 minute every 30 days, 10 minutes the every 6 months and 30 minutes every 12 months. The unit shall be supplied with a test switch and diagnostic LED indicator lights to continuously monitor the status of the unit: Battery Failure, Battery Disconnect, Charger Failure, Lamp Failure, Service Alarm, main voltage AC "ON", Charger High Rate.

The unit shall be CSA Certified to C22.2 no.141.

The unit shall be **Emergi-Lite®** model: \_\_\_\_\_.

## REPLACEMENT LAMPS

ORDERING CODE	LAMP TYPE	VOLTAGE/ WATTAGE
580.0074-E	MR16	6V-6W
580.0079-E	MR16	6V-10W
580.0080-E	MR16	12V-12W
580.0068-E	MR16	12V-20W
580.0097-E	MR16 LED	6V-4W
580.0093-E	MR16 LED	12V-4W
580.0104-E	MR16 LED	12V-5W
580.0106-E	MR16 LED	12V-6W

Project/Location:

Contractor:

Date:

Prepared by:

# JEM18P Series

## Compact Emergency Lighting Units



### FEATURES

- Compact emergency lighting unit available in factory white
- Fully automatic, solid state, voltage sensitive charger with test switch and AC-on pilot light
- Sealed dust-proof transfer relay circuit and low voltage disconnect
- Long-life, maintenance-free sealed Lead-Calcium battery
- Housing and heads constructed of injection molded, high impact, corrosion resistant thermoplastic
- 120VAC standard input
- 60 minutes run time
- CSA C22.2 No. 141 certified

### TYPICAL SPECIFICATIONS

The contractor will install the **Emergi-Lite® JEM18P Series** compact emergency lighting unit. The unit housing shall be made of injection moulded, high impact, corrosion resistant thermoplastic. The unit dimensions including the emergency heads shall be less than 24.1cm x 17.1cm x 12.4cm. The unit shall be rated 120VAC 60Hz input and 6VDC nominal output. The unit shall contain a fully automatic, solid-state battery charger with test switch and AC-on pilot light. The charger shall be computer tested and shall contain low-voltage disconnect circuitry to protect the battery from deep discharge. The battery shall be maintenance-free, sealed lead-calcium and shall supply the emergency heads with power for minimum 60 minutes during an AC power failure.

The unit shall include two emergency heads built of flame-retardant thermoplastic and shall include two mini-tungsten 6V-9W lamps.

The unit shall be CSA C22.2 no 141.

The unit shall be **Emergi-Lite®** Model: \_\_\_\_\_ .

### DIMENSIONS

Dimensions are approximate and subject to change.

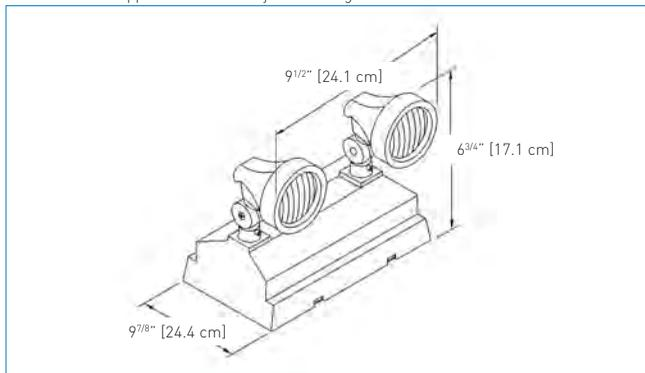

### WIRE GUARDS

460.0082-E	Wall Mount or Ceiling Mount
------------	-----------------------------

### REPLACEMENT LAMPS

ORDERING CODE	LAMP TYPE	VOLTAGE/WATTAGE
570.0016-E	Mini tungsten	6V-9W

### ORDERING INFORMATION

SERIES	CAPACITY	LAMP	COLOUR	VOLTAGE
JEM= compact plastic	18P= 18W	Blank= 6V-9W	Blank= factory white	Blank= 120VAC input

EXAMPLE: JEM18P



# Premier™ Series

Thermoplastic, 6 and 12V

Project/Location:
Contractor:
Date:
Prepared by:

## FEATURES

- Designed with aesthetics, ease of installation and performance in mind
- Simple, compact and contemporary design
- Wall-mount, ceiling-mount flat or pendant installation
- Two-piece housing of injection-molded thermoplastic
- Two MR16 halogen lamps, shielded by clear polycarbonate covers
- Available with long lasting MR16 LED lamps
- Sealed, maintenance-free, Lead-Calcium battery
- Dual voltage input: 120/347VAC.
- Up to 150W of total battery capacity
- Auto-diagnostics (optional)
- NEXUS® interface (optional)
- Certified CSA 22.2 No.141



## TYPICAL SPECIFICATIONS

Supply and install the **Emergi-Lite® Premier™ Series** battery unit equipment. The unit construction shall include a housing and a front cover of high-impact thermoplastic moulded in white. No screws shall be necessary to hold the front cover to the housing. The unit shall be equipped with two emergency heads with adjustable swivels and MR-16 lamps of \_\_\_\_\_ V \_\_\_\_\_ W protected by snap-on shock-absorbent, clear polycarbonate covers. The unit shall be suitable for wall mount or as otherwise specified.

The unit equipment shall have a dual-voltage input of 120/347VAC and shall be equipped with a test switch and a green pilot light, located on the left side. The housing shall host the battery and the battery charger. The battery charger and other unit functions shall be driven by a micro-controller. All electronic circuitry shall be installed on a single printed circuit board.

When specified, the unit equipped with auto-test shall automatically self-test for one minute every 30 days, 10 minutes every 6 months and 30 minutes annually. When a fault is detected, the bi-colour pilot light shall turn from green to red and start flashing. A legend on a label next to the pilot light shall display the source of failure: battery, charger circuitry or lamp load.

The unit equipment shall be listed to the standard CSA 22.2 No.141.

The unit equipment shall be **Emergi-Lite®** model: \_\_\_\_\_.

## WIRE GUARDS

460.0114-E	Wall Mount or flat ceiling mount
------------	----------------------------------

## REPLACEMENT LAMPS

ORDERING CODE	LAMP TYPE	VOLTAGE/ WATTAGE
580.0079-E	MR16 halogen	6V-10W
580.0080-E	MR16 halogen	12V-12W
580.0064-E	MR16 halogen	12V-20W
580.0093-E	MR16 LED	12V-4W
580.0097-E	MR16 LED	6V-4W
580.0104-E	MR16 LED	12V-5W
580.0106-E	MR16 LED	12V-6W

## PREMIER™ FAMILY

	
<b>Premier™ Combo Series</b>	<b>Premier™ Exit Series</b>
P. 56-57	P. 55

Project/Location:

Contractor:

Date:

Prepared by:

# Premier™ Series

Thermoplastic, 6 and 12V



## DIMENSIONS

Dimensions are approximate and subject to change.

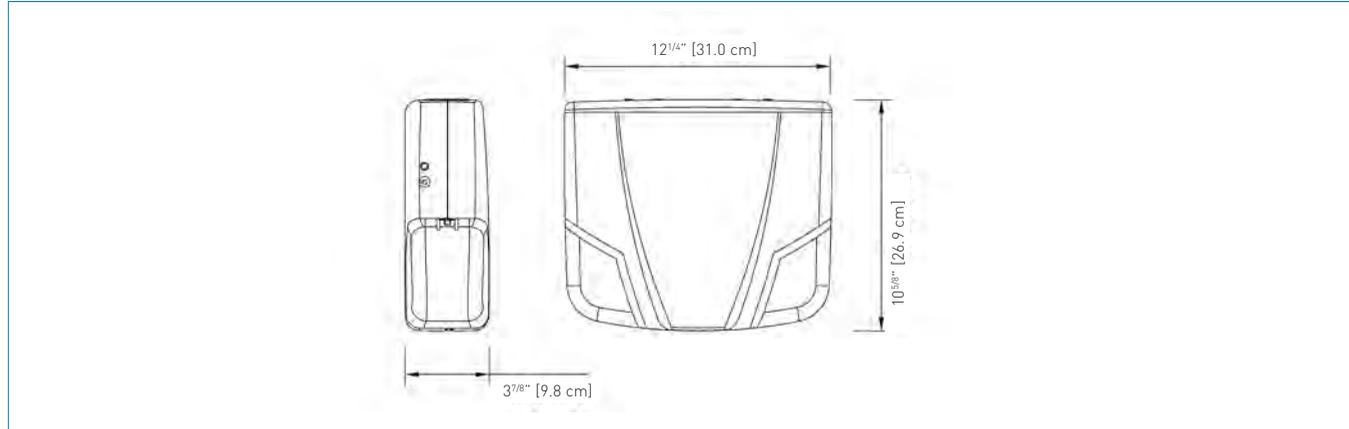

## FLAT CEILING MOUNT



## POWER CONSUMPTION AND UNIT RATING

MODEL	AC SPECS		WATTAGE CAPACITY				
			30MIN	1H00	1H30	2H00	4H00
PRE40	120/347VAC	0.25 / 0.09 A	40	23	16	12	-
PRE72			72	42	30	24	12
12PRE80			80	44	32	26	13
12PRE120			120	70	50	40	20
12PRE150			150	84	60	48	24

## ORDERING INFORMATION

SERIES	CAPACITY	COLOUR	VOLTAGE	UNIT TYPE	OPTIONS	HEADS	LAMPS
06PRE= 6V	40= 40W 72= 72W	W= factory white B= black	Blank= 120/347VAC 2= 120/277VAC	Blank= standard U= auto-diagnostics* UN= auto-diagnostics non-audible* NEX= NEXUS® system interface** NEXRF= NEXUS® wireless system interface**	Blank= no options CM= ceiling mount D3= time delay (15 minutes) LC= line cord (120V) PM= pendant mount	/0= no heads /2= two heads	LA= MR16 LED, 6V-4W LG= MR16 LED, 12V-4W LI= MR16 LED, 12V-5W LJ= MR16 LED, 12V-6W MI= MR16, 6V-6W MJ= MR16, 6V-10W MK= MR16, 12V-12W MW= MR16-IR, 12V-20W
12PRE= 12V	80= 80W 120= 120W 150= 150W						

\* Minimum lamp load required: 20% of unit capacity  
 \*\* Not all options are available with the Nexus® system. Please consult your sales representative

EXAMPLE: 06PRE40W/2MI



# ESL Series

6, 12 and 24V

Project/Location: \_\_\_\_\_

Contractor: \_\_\_\_\_

Date: \_\_\_\_\_

Prepared by: \_\_\_\_\_

## 10-year life expectancy, maintenance-free emergency lighting units.

The **ESL Series** battery units combine long life expectancy, high-performance design and a reasonable initial cost outlay. Ideally suited for a range of commercial applications, the long-life lead acid battery is specifically recommended for environments where the unit will be exposed to large variances in ambient temperature.

### FEATURES

- Rugged steel cabinet with corrosion-resistant undercoating
- Removable front panel on cabinet provides easy access and allows the unit to be mounted at ceiling height
- Solid-state pulse-type charger – current-limited, temperature-compensated, short-circuit proof and reverse-polarity protected.
- Unit comes standard with electronic lockout and brownout circuits
- Sealed dust-proof transfer relay, test switch and LED indicator lights
- Long-life, maintenance-free lead acid battery
- NEXUS® compatible (for more information on NEXUS®, please consult your sales representative)
- CSA C22.2 No. 141 certified
- Standard 120/347 VAC input with line cord kit



CABINET	DIMENSIONS				
	A	B	C	D	E
A	13 1/4" (33.7 cm)	3 5/8" (9.2 cm)	10 1/2" (26.7 cm)	14 1/4" (36.2 cm)	16 1/2" (41.9 cm)
B	16 1/8" (40.9 cm)	5 1/2" (13.9 cm)	10 1/4" (26.0 cm)	13 7/8" (35.2 cm)	16 1/8" (41.0 cm)
C	23 1/8" (58.7 cm)	5 1/2" (13.9 cm)	10 1/4" (26.0 cm)	13 7/8" (35.2 cm)	16 1/8" (41.0 cm)

### DIMENSIONS

Dimensions are approximate and subject to change.

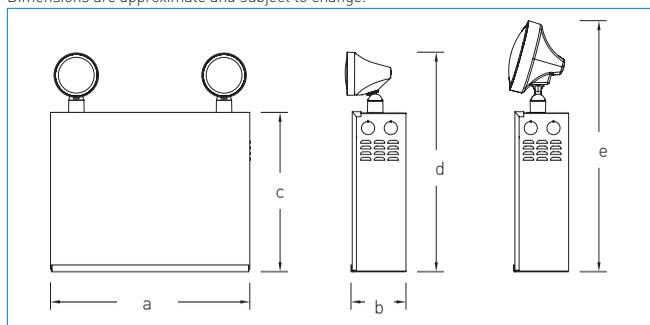

### TYPICAL SPECIFICATIONS

Supply and install a complete emergency lighting system as described herein and shown on the drawings.

The **Emergi-Lite® Smart Diagnostic** micro-controller board shall supply the rated load for a minimum of a 1/2 hour to 87.5% of the rated battery voltage. The unit shall be rated 120V or 347V, 60 Hz and be CSA listed. The unit shall have an output of: \_\_\_\_\_V and \_\_\_\_\_W.

The charger shall be fully computer tested and its charge voltage factory set to ± 1% tolerance. Chargers with field-adjusted potentiometers are not acceptable. A pulse-type charger shall be employed to promote long battery life and reduce the potential for grid corrosion. The charger shall provide a continuous high charge to recharge the battery, and when the battery is at full capacity, the charger will shut off.

Periodically the charger shall provide a pulse of energy to keep the battery topped off. The pulse charger shall be precisely regulated and shall charge the battery in relation to its temperature, state or charge and input voltage fluctuations. The charger shall be current limited, temperature compensated, short-circuit proof and reverse polarity protected.

The unit shall be furnished with an electronic lockout circuit, which will connect the battery when the AC circuit is activated, and an electronic brownout circuit, which will activate the emergency lights when utility power dips below 75% of nominal voltage. A low voltage battery protection circuit shall be provided and will disconnect the load when the battery reaches the end of discharge. The unit shall self-test for 1 minute every 30 days, 10 minutes every 6 months and 30 minutes every 12 months. The unit shall be capable of full recharge in compliance with CSA specifications. The unit shall be furnished with a sealed dust tight relay, a test switch and diagnostic LED indicator lights to continuously monitor the status of the unit: Battery Failure, Battery Disconnected, Charger Failure, Lamp Failure, Service Alarm, AC "ON", Charger High Rate. The emergency lighting heads shall require no tools for orientation.

The unit shall be **Emergi-Lite®** model: \_\_\_\_\_.

### WIRE GUARDS

460.0078-E	Wall Mount	"A" Cabinet
460.0081-E	Wall Mount	"B" Cabinet
460.0034-E	Wall Mount	"C" Cabinet

### REPLACEMENT LAMPS

ORDERING CODE	LAMP TYPE	VOLTAGE/WATTAGE
570.0016-E	Mini tungsten (MT9W)	6V-9W
570.0025-E	Mini tungsten (MT9W)	12V-9W
570.0045-E	Mini tungsten (MT9W)	24V-9W
580.0093-E	MR16 LED	12V-4W
580.0104-E	MR16 LED	12V-5W
580.0098-E	MR16 LED	24V-4W
580.0106-E	MR16 LED	12V-6W

For the complete list, please see the lamp chart on pages 156 to 158

Project/Location:

Contractor:

Date:

Prepared by:

# ESL Series

6, 12 and 24V



## POWER CONSUMPTION AND UNIT RATING

MODEL	AC SPECS		WATTAGE CAPACITY				
			30 MIN	1H00	1H30	2H00	4H00
06ESL36	120/347VAC	0.10/0.04 A	36	21	15	12	6
06ESL72		0.22/0.08 A	72	42	30	24	12
06ESL108		0.22/0.08 A	108	63	45	36	18
06ESL180		0.22/0.08 A	180	105	75	60	30
12ESL36		0.09/0.03 A	36	21	15	12	6
12ESL72		0.15/0.06 A	72	42	30	24	12
12ESL100		0.34/0.12 A	100	58	42	33	17
12ESL144		0.40/0.14 A	144	84	60	48	24
12ESL216		0.41/0.14 A	216	117	83	67	33
12ESL250		0.41/0.14 A	250	144	100	38	42
12ESL360		0.41/0.14 A	360	200	144	108	60
24ESL144		0.43/0.15 A	144	84	60	48	24
24ESL200		0.55 / 0.20 A	200	117	83	67	33
24ESL288		0.67 / 0.23 A	288	168	120	96	48
24ESL350		0.67 / 0.23 A	350	200	144	120	60
24ESL432		0.67 / 0.23 A	432	250	180	144	72
24ESL550		0.88 / 0.33 A	550	320	230	180	90
24ESL720		0.88 / 0.33 A	720	420	300	240	120

Note: Low wattage LED lamps provide extended time of emergency lighting without additional power.

## ORDERING INFORMATION

SERIES	CAPACITY	COLOUR	VOLTAGE	OPTIONS	# OF HEADS	HEADS STYLE/WATTAGE
06ESL= 6V	36= 36W (A) 72= 72W (A) 108= 108W (A) 180= 180W (B)	Blank= factory white BK= black	Blank= 120/347VAC input -2= 277VAC input	A= ammeter CT= cab-tire D= time delay LW= cord and twist-lock plug 120V P= light activated test switch T= lamp disconnect TB= DC terminal block TBAC= AC terminal block TX2= remote test transmitter U= auto-diagnostics* UN= auto-diagnostics non-audible* V= voltmeter X2= remote test receiver** FB6= 6 circuit fuse panel NEX= NEXUS® system interface*** NEXRF= wireless NEXUS® system interface*** TBACDC= AC/DC terminal block	/0= no heads /1= one head /2= two heads /3= three heads	Blank= large tungsten, 6V, 12V, 24V-9W, wedge base -18= large tungsten, 12V, 24V-18W, wedge base -25= large tungsten, 6V, 12V, 24V-25W, DCB LA= MR16 LED, 6V-4W LG= MR16 LED, 12V-4W LL= MR16 LED, 24V-4W LI= MR16 LED, 12V-5W LJ= MR16 LED, 12V-6W H= large halogen, 6V, 12V-8W, quartz sealed beam H12= large halogen, 6V, 12V-12W, quartz sealed beam H20= large halogen, 6V-20W, quartz sealed beam M= mini tungsten, 6V, 12V, 24V-9W, wedge base M18= mini tungsten, 12V, 24V-18W, wedge base MQ= mini halogen, 6V, 12V-8W, quartz bi-pin MQ12= mini halogen, 6V, 12V, 24V-12W, quartz bi-pin MI= MR16, 6V-6W MJ= MR16, 6V-10W MK= MR16, 12V-12W MN= MR16, 24V-20W MA= MR16, 12V-20W MS= MR16, 24V-12W MW= 12V-20W, high-output Q= large halogen, 6V, 12V-8W, quartz bi-pin Q12= large halogen, 6V, 12V-12W, quartz bi-pin Q20= large halogen, 6V, 12V, 24V-20W, quartz bi-pin Q55= large halogen, 12V-55W, quartz H3 Q70= large halogen 24V-70W, quartz H3 S= large tungsten, 6V, 12V-8W, sealed beam S18= large tungsten, 6V, 12V-18W, sealed beam S25= large tungsten, 6V, 12V-25W, sealed beam
12ESL= 12V	36= 36W (A) 72= 72W (A) 100= 100W (A) 144= 144W (A) 216= 216W (B) 250= 250W (B) 360= 360W (C)					
24ESL= 24V	144= 144W (A) 200= 200W (B) 288= 288W (B) 350= 350W (C) 432= 432W (C) 550= 550W (C) 720= 720W (C)					

\* Minimum lamp load required: 20% of unit capacity

\*\* Remote test transmitter needed.

\*\*\* Not all options available with NEXUS®. Consult your sales representative.

EXAMPLE: 06ESL108U/2M



# Survive-All™ NXM Series

NEMA-4X Certified

Project/Location:
Contractor:
Date:
Prepared by:

## FEATURES

- Fully gasketed cast aluminum back plate with clear polycarbonate cover – NEMA-4X Certified
- Comes standard with non-audible advanced diagnostic, 10 minutes time delay and lamp disconnect
- Audible warning and time delay functions can be enabled or disabled during installation
- Micro-controller diagnostic system tests, detects and indicates battery, charger circuitry or MR16 lamp failures
- Non-intrusive magnetic test switch
- Long-life, maintenance-free sealed lead-acid battery
- 1/2" rigid conduit entry on top and back
- Can be installed on 4" junction boxes
- Comes standard with tamper-proof screws and bit
- Cold weather option -40°C (-40°F)
- NSF Certified for food processing plants
- CSA C22.2 No. 141 Certified
- NEXUS® compatible
- Standard 120/347VAC input voltage

## TYPICAL SPECIFICATIONS

Supply and install the **Emergi-Lite® NEMA-4X Certified Survive-All™ NXM Series** battery unit. Specifically designed for high abuse areas, wet locations, and cold weather (CW option -40°C [-40°F]), the housing shall consist of a fully gasketed Die-Cast with a cast aluminum back plate and a clear heavy-duty UV resistant polycarbonate cover. The heads shall be fully adjustable without tools and the lamps shall be high efficiency halogen MR16. The standard unit shall be equipped with tamper-proof screws and bits. The **Emergi-Lite® Advanced Diagnostic** Micro-controller charger board shall supply the rated load for a minimum of 30 minutes to 87.5% of the rated battery voltage. The charger incorporates lockout and brownout circuits, and low voltage disconnection. It protects the unit from over-current, short-circuit, and reverse polarity. The unit shall be rated 120/347V, 60Hz. The unit shall have an output of \_\_\_\_\_ V. This unit shall self-test for 1 minute every 30 days, 10 minutes every 6 months and 30 minutes every 12 months. The unit shall be furnished with a non-intrusive magnetic test switch. A "Service Required" lamp shall be located near the test switch and flash when a fault is detected. A four-LED diagnostic display shall be located inside the equipment and shall identify the source of failure (battery, charger, circuitry, or lamps).

The unit shall be **Emergi-Lite®** model: \_\_\_\_\_

## WIRE GUARDS

460.0031-E	Wall Mount
------------	------------

## REPLACEMENT LAMPS

ORDERING CODE	LAMP TYPE	VOLTAGE/ WATTAGE
580.0074-E	MR16 halogen	6V-6W
580.0079-E	MR16 halogen	6V-10W
580.0080-E	MR16 halogen	12V-12W
580.0064-E	MR16 halogen	12V-20W
580.0104-E	MR16 LED	12V-5W
580.0097-E	MR16 LED	6V-4W
580.0106-E	MR16 LED	12V-6W



## SURVIVE-ALL™ NEMA 4X & NSF CERTIFIED FAMILY

ENC SERIES	LPEX600 SERIES	LPEX600-N SERIES	EN SERIES	EF39 SERIES
P. 62	P. 61	P. 63	P.112-113	P.136

Project/Location:

Contractor:

Date:

Prepared by:

# Survive-All™ NXM Series

NEMA-4X Certified



## DIMENSIONS

Dimensions are approximate and subject to change.

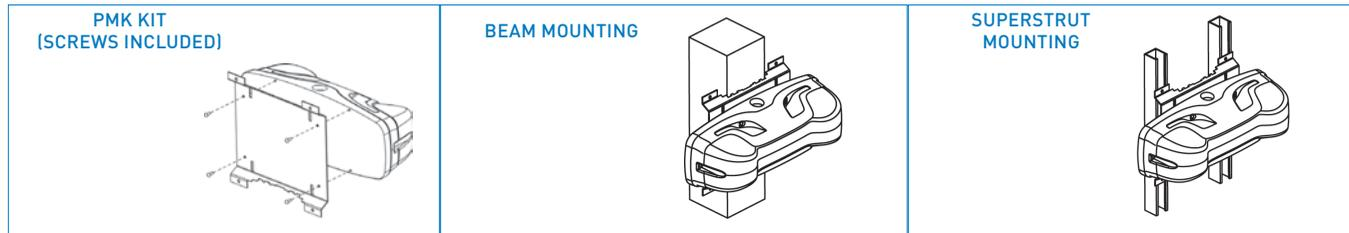
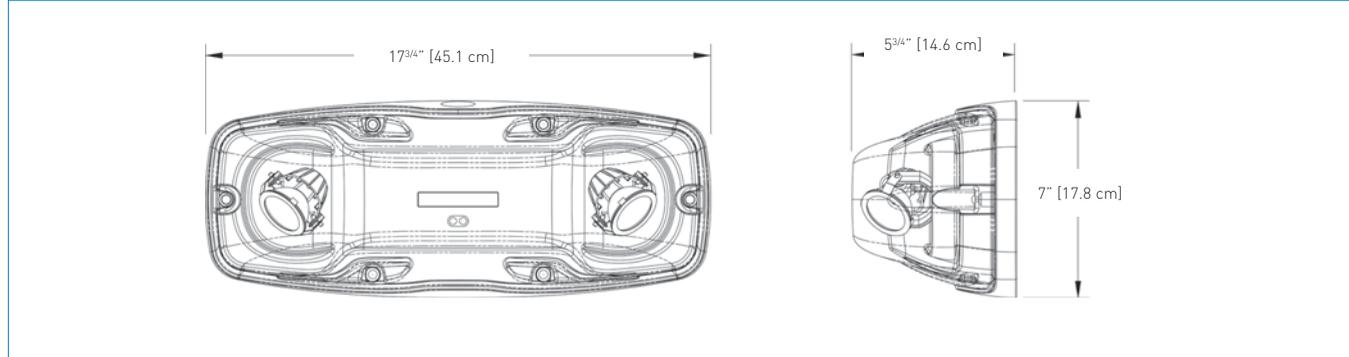

## POWER CONSUMPTION AND UNIT RATING

MODEL	AC SPECS		WATTAGE CAPACITY				
			30MIN	1H00	1H30	2H00	4H00
06NXM36	120/347VAC	0.15/0.06 A	36	21	15	12	6
12NXM72		0.25/0.10 A	72	42	30	24	12
12NXM108		0.25/0.10 A	108	63	45	36	18
Cold Weather 36W		0.45/0.20 A	36	-	-	-	-
Cold Weather 72/108W	120VAC	0.85 A	72/108	-	-	-	-

\*Note: capacity depends on the ambient temperature

## ORDERING INFORMATION

SERIES	COLOUR	CAPACITY	VOLTAGE	OPTIONS	# OF HEADS	LAMP
<b>06NXM</b> = 6V, NEMA-4X <b>12NXM</b> = 12V, NEMA-4X	<b>W</b> = white <b>BK</b> = black <b>G</b> = grey	<b>36</b> = 6V-36W <b>72</b> = 12V-72W <b>108</b> = 12V-108W	<b>Blank</b> = 120/347VAC <b>2</b> = 277VAC	<b>Blank</b> = no options <b>CW1</b> = cold weather 120VAC <b>CW3</b> = cold weather 347VAC* <b>NEX</b> = NEXUS® system interface** <b>NEXRF</b> = wireless NEXUS® system interface** <b>PMK-E</b> = universal bracket (sold separately) <b>690.0454-E</b> = additional-bit for tamper-proof screws (sold separately)	/2= 2 heads	<b>LA</b> = MR16 LED, 6V-4W* <b>LG</b> = MR16 LED, 12V-4W* <b>LI</b> = MR16 LED, 12V-5W <b>LJ</b> = MR16 LED, 12V-6W <b>MI</b> = MR16, 6V-6W <b>MJ</b> = MR16, 6V-10W <b>MK</b> = MR16, 12V-12W <b>MG</b> = MR16, 12V-20W* <b>MW</b> = MR16-IR, 12V-20W

\*Available in 6V only.

\*\*Consult your sales representative for options available with the NEXUS® system.

\*Minimum lamp load required: 20% of unit capacity

EXAMPLE: 06NXMW36/2MI



# IPE Series

IP65 Linear  
Fluorescent Fixture

Project/Location:

Contractor:

Date:

Prepared by:

## FEATURES

- IP65 rated
- Polycarbonate enclosure and lens, vandal resistant and UV stabilized
- Rust proof hardware
- Ceiling, surface or pendant mounting
- Low profile, less than 4" deep
- Ultra efficient specular reflector with optimized shape
- 32W T8 or 54W T5HO
- 90 minutes of emergency operation when installed with our FPSI or FPSU inverters
- Emergency operation from external DC low voltage power source when installed with our 48 Series inverters
- Suitable for wet locations
- CSA certified to CSA-E60598-1: 02



## DIMENSIONS

Dimensions are approximate and subject to change.

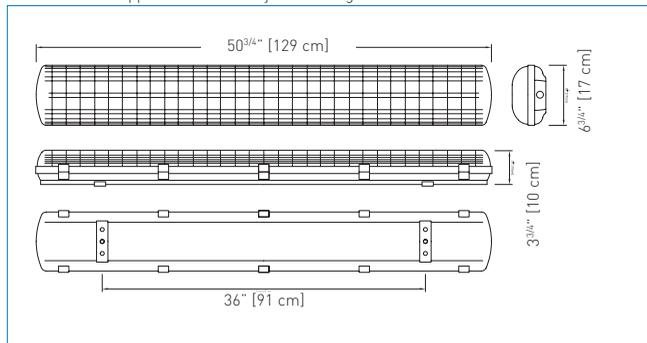

## TYPICAL SPECIFICATIONS

Supply and install **Emergi-Lite® IPE Series** fluorescent fixtures as specified. The luminaire shall operate from 120VAC to 277VAC or 347VAC and use high quality instant start or 3-step programmed rapid start high efficiency electronic ballasts.

The body and lens shall be constructed of UV stabilized industrial grade vandal-resistant polycarbonate. A durable formed gasket shall be provided between the enclosure and the lens and shall be designed specifically for hostile environments. The reflector shall be made of highly specular material and formed to maximize light output efficiency. All parts shall be corrosion resistant. A metal plate used to retain the ballast and reflector also serves to dissipate heat, therefore lengthening ballast life.

Lamps shall be as specified, either T8 or T5 HO linear fluorescent lamps, 32W or 54W. The lamps shall not be supplied with the luminaire. Models with an inverter from the **FPSI/FPSU Series** shall illuminate one or two lamps during emergency operation for at least 90 minutes upon AC failure. During power outage, dual voltage source (AC/DC) models with an inverter from the **48 Series** shall illuminate one lamp while the DC voltage is present.

The fixture shall be CSA approved and meet IP65 designation requirements.

The inverters of **Series 48** shall be CSA approved.

The inverters of the **FPS Series** shall be CSA or cUL approved.

The fixture shall be **Emergi-Lite®** model: \_\_\_\_\_

## WIRE GUARDS

460.0105-E	Wall Mount or Ceiling Mount
------------	-----------------------------

## POWER CONSUMPTION

MODEL		AC SPECS	
IPE8	120/277VAC	0.54/0.23 A	PF > 0.9
IPE83	347VAC	0.19 A	PF > 0.9
IPE5	120/277VAC	1.03/0.143 A	PF > 0.9
IPE53	347VAC	0.35 A	PF > 0.9

## ORDERING INFORMATION

SERIES	LAMP TYPE*	VOLTAGE	ACCESSORIES
IPE= 48" (122cm) linear fluorescent	8= 2x lamps 32W T8 5= 2x lamps 54W T5HO	Blank= AC only 120/277VAC 3= AC only 347VAC DC= 120VAC/VDC	<b>Self-powered, one lamp emergency</b> FPSI-32= inverter for IPE8 [complete code = IPE8FPSI-32] FPSIU-3= inverter for IPE8-3 [complete code = IPE8-3FPSIU-3] FPSIU= inverter for IPE5 [complete code= IPE5FPSIU]
			<b>Self-powered, two lamps emergency</b> FPSU-28= inverter for IPE8 [complete code= IPE8FPSU-28] FPSIU-3= inverter for IPE8-3 [complete code= IPE8-3FPSIU-3]
	Lamps not included		4806100= 6V, 120VAC 4806100-3= 6V, 347VAC 4812100= 12V, 120VAC 4812100-3= 12V, 347VAC 4824100= 24V, 120VAC 4824100-3= 24V, 347VAC 081282-E= Stainless Steel Clips Kit (10)
			4832100= 32V, 120VAC 4832100-3= 32V, 347VAC 4848100= 48V, 120VAC 4848100-3= 48V, 347VAC 48120100= 120V, 120VAC 48120100-3= 120V, 347VAC

EXAMPLE: IPE8

Project/Location: \_\_\_\_\_

Contractor: \_\_\_\_\_

Date: \_\_\_\_\_

Prepared by: \_\_\_\_\_

# SIPE Series

IP65 Linear 2'  
Fluorescent Fixture



## FEATURES

- Normally On fluorescent fixture
- IP65 rated
- Polycarbonate enclosure and lens, vandal resistant and UV stabilized
- Rust proof hardware
- Ceiling, surface or pendant mounting
- Low profile, less than 4" deep
- Ultra efficient specular reflector with optimized shape
- 17W T8 or 24W T5HO
- High efficiency and reliable electronic ballast
- 120VAC to 277VAC universal and 347VAC input voltage available
- CSA certified to CAN/CSA-E60598-1:02
- Certified for wet and damp locations
- Certified for AC or DC, 120V operations



## INPUT RATING

ORDERING CODE	INPUT	CURRENT
SIPE8	120 - 277/347VAC	0.47/0.20/0.1 A
	120VDC	0.3 A
SIPE5	120 - 277/347VAC	0.5/0.22 A

## TYPICAL SPECIFICATIONS

Supply and install **Emergi-Lite® SIPE Series** fluorescent fixtures as specified.

The luminaire shall operate from 120VAC to 277VAC or 347VAC and use high quality instant start or 3-step programmed rapid start high efficiency electronic ballasts.

The body and lens shall be constructed of UV stabilized industrial grade vandal resistant polycarbonate. A durable formed gasket shall be provided between the enclosure and the lens and shall be designed specifically for hostile environments. The reflector shall be made of highly specular material and formed to maximize light output efficiency. All parts shall be corrosion resistant. A metal plate used to retain the ballast and reflector also serves to dissipate heat, therefore lengthening ballast life.

Lamps shall be as specified, either T8 or T5 HO linear fluorescent lamps, 17W or 24W. The lamps shall not be supplied with the luminaire.

Models with an inverter from the **FPS/48 Series** will illuminate one or two lamps during emergency operation for at least 90 minutes upon AC failure. During power outage, dual voltage source (AC/DC) models with an inverter from the 48 Series shall illuminate one lamp while the DC voltage is present. The fixture shall be CSA approved and meet IP65 designation requirements.

The inverters of **48 Series** shall be CSA approved.

The inverters of the **FPS Series** shall be CSA or cUL approved.

The fixture shall be **Emergi-Lite®** model: \_\_\_\_\_

## WIRE GUARDS

460.0106-E	Wall Mount or Ceiling Mount
------------	-----------------------------

## DIMENSIONS

Dimensions are approximate and subject to change.

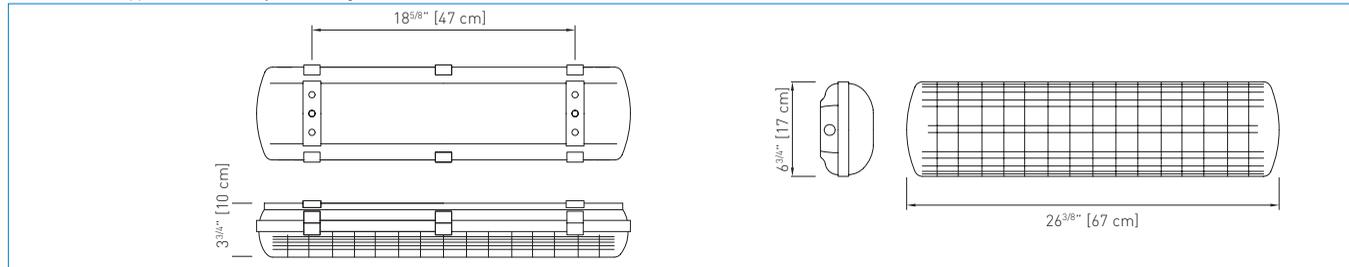

## ORDERING INFORMATION

SERIES	LAMP TYPE*	VOLTAGE
SIPE= vapour proof 24"	<b>8</b> = 2 F17T8 17W T8 lamps <b>5</b> = 2 T5HO 24W T5 lamps  *Lamps not included	<b>Blank</b> = 120/277VAC <b>3</b> = AC only 347VAC <b>DC</b> = 120/277VAC/VDC

EXAMPLE: SIPE8



# ESLPK Series

6, 12 and 24V  
NEMA-12 Classified

Project/Location: \_\_\_\_\_

Contractor: \_\_\_\_\_

Date: \_\_\_\_\_

Prepared by: \_\_\_\_\_

## Harsh environment emergency lighting units with steel, thermoplastic or fiberglass cabinets.

The **ESLPK Series** battery units are specifically designed for use in industrial facilities where equipment is exposed to dust, water, oil or corrosive substances. NEMA-12 classified to protect circuitry from harmful dust or liquid sprays, sealed and gasketed unit cabinets are available in steel, thermoplastic or fiberglass in a variety of sizes.

### FEATURES

- Solid-state pulse-type charger – current-limited, temperature compensated, short-circuit proof and reverse-polarity protected.
- Unit comes standard with electronic lockout and brownout circuits
- Sealed dust-proof transfer relay, test switch and LED indicator lights
- Long-life, maintenance-free sealed lead acid battery
- NEXUS® compatible (for more information on NEXUS®, please consult your sales representative)
- CSA C22.2 No. 141 certified
- Standard 120/347 VAC input with line cord kit



nexus®

### DIMENSIONS

Dimensions are approximate and subject to change.

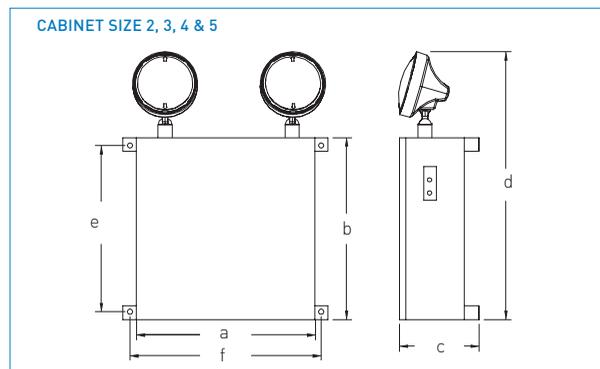
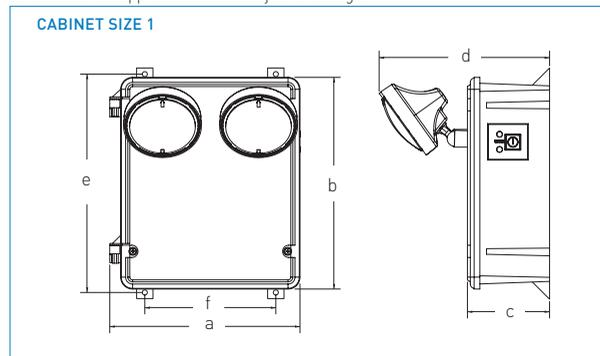

### TYPICAL SPECIFICATIONS

Supply and install a complete emergency lighting system as described herein and shown on the drawings. The **Emergi-Lite® Smart Diagnostic** Micro controller board shall supply the rated load for a minimum of a 1/2 hour to 87.5% of the rated battery voltage. The unit shall be rated 120V or 347V, 60 Hz and be CSA listed. The unit shall have an output of \_\_\_\_\_ V. The charger shall be fully computer tested and its charge voltage factory set to  $\pm 1\%$  tolerance. Chargers with field-adjusted potentiometers are not acceptable. A pulse-type charger shall be employed to promote long battery life and reduce the potential for grid corrosion. The charger shall provide a continuous high charge to recharge the battery and when the battery is at full capacity, the charger will shut off. Periodically the charger shall provide a pulse of energy to keep the battery topped off. The Pulse charge shall be current limited and precisely regulated by a micro-processing circuit, which samples the battery in relation to its temperature, state of charge and input voltage fluctuations. The charger shall be current limited, temperature compensated, short-circuit proof and reverse polarity protected. The unit shall be furnished with an electronic lockout circuit, which will connect the battery when the AC circuit is activated, and an electronic brownout circuit, which will activate the emergency lights when utility power dips below 75% of nominal voltage. A low voltage battery protection circuit shall be provided and will disconnect the battery from the fused output circuit at the end of discharge. The unit shall self-test for 1 minute every 30 days, 10 minutes every 6 months and 30 minutes every 12 months. The unit shall be capable of full recharge in compliance with CSA specifications. The unit shall be furnished with a sealed dust tight relay, a test switch and diagnostic LED indicator lights to continuously monitor the status of the unit: Battery Failure, Battery Disconnected, Charger Failure, Lamp Failure, Service Alarm, AC "ON", Charger High Rate.

The unit shall be **Emergi-Lite®** model: \_\_\_\_\_.

### WIRE GUARDS

460.0034-E	Wall Mount
------------	------------

CABINET	DIMENSIONS					
	A	B	C	D	E	F
Size 1 Thermoplastic	11 <sup>5/8"</sup> (29.5 cm)	13" (33.0 cm)	5" (12.7 cm)	10 <sup>3/8"</sup> (26.4 cm)	12 <sup>15/16"</sup> (32.8 cm)	8" (20.3 cm)
Size 2 Fiberglass	13 <sup>1/4"</sup> (33.8 cm)	15 <sup>3/8"</sup> (38.9 cm)	6 <sup>3/4"</sup> (17.0 cm)	21" (53.3 cm)	14 <sup>3/4"</sup> (37.5 cm)	8 <sup>1/8"</sup> (20.6 cm)
Size 3 Fiberglass	16 <sup>3/8"</sup> (41.5 cm)	24 <sup>1/4"</sup> (61.5 cm)	9 <sup>1/4"</sup> (23.4 cm)	30 <sup>3/8"</sup> (77.3 cm)	-	-
Size 4 Steel	13" (33.0 cm)	13 <sup>1/4"</sup> (33.8 cm)	5 <sup>7/8"</sup> (14.8 cm)	19 <sup>1/2"</sup> (49.6 cm)	12 <sup>1/8"</sup> (30.8 cm)	13 <sup>15/16"</sup> (35.3 cm)
Size 5 Steel	16" (40.6 cm)	20" (50.8 cm)	9 <sup>1/8"</sup> (23.3 cm)	26 <sup>1/4"</sup> (66.7 cm)	-	-

### REPLACEMENT LAMPS

MODEL	LAMP TYPE	VOLTAGE/WATTAGE
570.0016-E	Mini-Tungsten (LH9W)	6V-9W
570.0025-E	Mini-Tungsten (LH9W)	12V-9W
570.0045-E	Mini-Tungsten (LH9W)	24V-9W





# HZM Series

Hazardous Location Battery Unit

Project/Location:
Contractor:
Date:
Prepared by:

## FEATURES

- Certified Class I Zone 2, Groups IIA, IIB and IIC
- Certified Class I Division 2, Groups A, B, C and D as per CSA C22.2 No.137-M1981
- Certified temperature codes for several types of emergency lamps
- Suited for areas with the risk of flammable gases, vapors or liquids that can create an explosive atmosphere
- Certified CSA C22.2 No141
- Polymeric frame, with built-in gasket to prevent water infiltration
- Heavy-duty 1/8" thick aluminum back plate with keyholes for secure wall-mount installation
- Two MR16 halogen or LED lamps, shielded by a cast aluminum housing and a polycarbonate cover
- Sealed, maintenance-free, Lead-Calcium batteries with up to 120W emergency power
- Built-in microcontroller-based battery charger and auto-diagnostics circuitry
- 1/2" electrical conduit entry on both sides and at the top
- NEXUS® compatible (for more information on NEXUS®, please contact your sales representative)



## TYPICAL SPECIFICATIONS

Supply and install **Emergi-Lite® HZM Series** battery units. Designed specifically for Hazardous Location environments, the equipment frame shall be of industrial grade polymeric material with gaskets around both sides of the contour. The frame shall be fixed between two plates made of 1/8" thick aluminum sheet. The back plate shall include four keyholes for wall-mount installation. The front plate shall include two water-tight lenses for pilot lights: AC-on and "Service required". When specified, the equipment shall have attached a lower compartment containing two emergency lights with adjustable swivels and MR-16 halogen lamps. The lamps shall be shielded by a cast aluminum housing and protected by a shock-absorbent, transparent polycarbonate cover.

The equipment shall be certified for Hazardous Locations: Class I Division 2 Groups A, B, C and D. The standard equipment shall have a dual voltage input: 120/347VAC and shall be equipped with a magnetic test switch located on the left side of the frame.

The unit shall include self-testing/self-diagnostic functions monitored by a micro-controller and shall automatically self test for one minute every 30 days, 10 minutes every 6 months and 30 minutes annually. The "Service required" LED shall light when a fault is detected. A four-LED diagnostic display located inside the equipment shall identify the source of the failure (battery, charger circuitry, lamp load).

The unit shall be listed CSA C22.2 No.141 and No. 137 – M1984

The battery unit shall be **Emergi-Lite®** model: \_\_\_\_\_ .

## TEMPERATURE CODES

LAMP RATING	TEMP. CODE	MAX. TEMP.	REPLACEMENT PART
6V-10W	T3C	160°C (320°F)	580.0079-E
12V-12W	T3A	180°C (356°F)	580.0080-E
12V-20W	T2D	215°C (419°F)	580.0068-E

Note: Use qualified replacement lamps to avoid risk of over-heating.

## POWER CONSUMPTION AND UNIT RATING

MODEL	AC SPECS		WATTAGE CAPACITY				
			30MIN	1H00	1H30	2H00	4H00
HZM36	120/347VAC	0.15/0.06 A	36	21	15	12	-
HZM72	120/347VAC	0.30/0.10 A	72	42	30	24	12
HZM120	120/347VAC	0.30/0.10 A	120	70	50	40	20
HZM150	120/347VAC	0.30/0.10 A	150	-	72	-	-

Project/Location:

Contractor:

Date:

Prepared by:

# HZM Series

## Hazardous Location Battery Unit



### DIMENSIONS

Dimensions are approximate and subject to change.

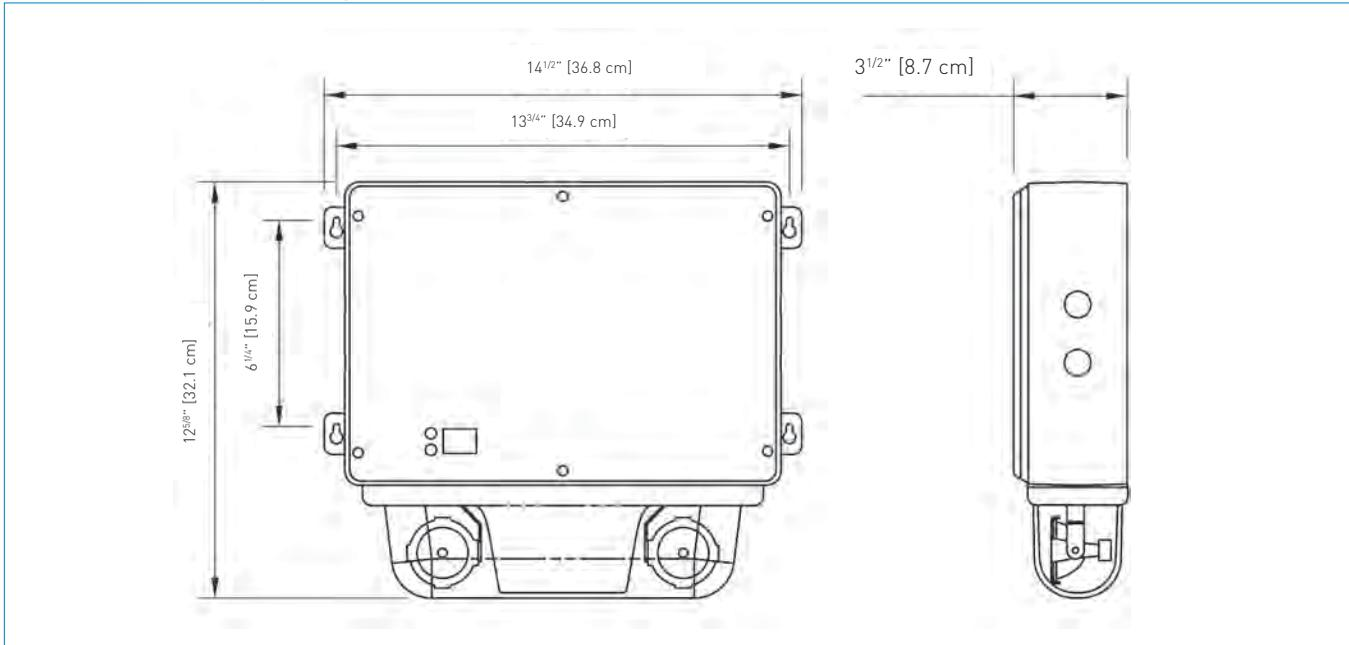

### ORDERING INFORMATION

SERIES	CAPACITY	COLOUR	AC VOLTAGE	OPTIONS	# OF HEADS	LAMP/WATTAGE
06HZM= 6V 12HZM= 12V	36= 6V-36W 72= 12V-72W 120= 12V-120W 150= 12V-150W	Blank= grey	Blank= 120/347VAC -2= 277VAC	U= auto-diagnostics, audible* UN= auto-diagnostics (non-audible)* NEX= NEXUS® system interface** NEXRF= wireless NEXUS® system interface**	/0= no heads /2= 2 heads	MJ= MR16, 6V-10W MK= MR16, 12V-12W MW= MR16-IR, 12V-20W LA= MR16 LED, 6V-4W LG= MR16 LED, 12V-4W LI= MR16 LED, 12V-5W

\* Minimum lamp load required: 20% of unit capacity  
\*\* Consult your sales representative for options available with the NEXUS® system.

EXAMPLE: 06HZM36UN/2MJ



# ESLNX Series

6, 12 and 24V  
NEMA-4X Rated

Project/Location:	_____
Contractor:	_____
Date:	_____
Prepared by:	_____

## FEATURES

- Delivers great pathway illumination up to 70 feet, center to center (with M20WH lamp)
- Fully gasketed fiberglass reinforced polyester housing - NEMA 4X
- Solid-state pulse-type charger – current – limited, temperature-compensated, short-circuit proof and reverse-polarity protected
- Unit comes standard with electronic lockout and brownout circuits
- Sealed dust-proof transfer relay, test switch and LED indicator lights
- Long-life, maintenance-free sealed lead acid battery
- Standard 120/347VAC input voltage with line cord kit
- NEXUS® compatible (for more information on NEXUS®, please consult your sales representative)
- Certified CSA C22.2 No. 141



## TYPICAL SPECIFICATIONS

Supply and install the **Emergi-Lite®** NEMA-4X Rated **ESLNX Series** battery unit. The unit shall be specifically designed for high abuse areas and wet locations. The unit enclosure shall be of fiberglass-reinforced polyester and shall include a hinged door, fully gasketed and locked with two corrosion-resistant screws. The emergency head(s) shall be installed at the bottom of the unit and/or at both sides and shall be covered by a UV-resistant polycarbonate cover. The bottom head shall include one or two lamps as specified. The unit shall come with two heads at the sides, each with one MR16 lamp. The lamps shall be high-efficiency, long-life halogen or LED type of:    V    W as specified. The lamp swivels shall be easily adjustable without tools. The unit enclosure shall include a test switch and a pilot light. The unit shall include sealed, maintenance-free Lead-Calcium batteries and an electronic module for the battery charger and other emergency lighting functions. The charger shall be computer-tested and its maximum charge voltage set in the factory with ± 1% tolerance.

A pulse-type charger shall be employed to promote long battery life and reduce the potential for grid corrosion. The charger shall provide a continuous high charge to recharge the battery and when the battery is at full capacity, the charger will shut off. Periodically the charger shall provide a pulse of energy to keep the battery topped off. The charger shall be current limited, temperature compensated and short-circuit proof. The unit shall be furnished with an electronic lockout circuit, which will connect the battery when the AC circuit is activated, and an electronic brownout circuit, which will activate the emergency lights when utility power dips below 75% of nominal voltage. A low voltage battery protection circuit shall be provided and will disconnect the battery from the fused output circuit at the end of discharge. When specified, the unit equipped with the **Emergi-Lite®** Auto-Diagnostic feature shall include a micro-controller based charger board that will generate an automatic test for 1 minute every 30 days, 10 minutes every six months and 30 minutes every 12 months.

The micro-controller circuitry shall ensure equipment readiness and reliability by continuously monitoring every critical function of the unit. If a component failure occurs, the pilot light located on the front of the unit will change color from green to red and will flash indicating a fault. A detailed diagnostic legend shall be available next to the pilot light and shall provide fault identification (battery, charger circuitry, lamps) for maintenance personnel. The unit shall be capable of full recharge in compliance with CSA specifications and supply the rated load for a minimum of a 1/2 hour to 87.5% of the rated battery voltage.

The unit shall be rated 120V or 347V, 60 Hz and shall have an output of:    V    W.

The unit shall be **Emergi-Lite®** model: \_\_\_\_\_.

## POWER CONSUMPTION AND UNIT RATING

MODEL	AC SPECS	WATTAGE CAPACITY				
		30MIN	1H00	1H30	2H00	4H00
06ESLNX72	0.22/0.08 A	72	42	30	24	12
06ESLNX108		108	63	45	36	18
06ESLNX180		180	105	75	60	30
12ESLNX72	0.15/0.06 A	72	42	30	24	12
12ESLNX100	0.34/0.12 A	100	58	42	33	17
12ESLNX144	0.40/0.14 A	144	84	60	48	24
12ESLNX200	0.41/0.14 A	200	117	83	67	33
12ESLNX250	0.41/0.14 A	250	120	90	83	42
12ESLNX360	0.41/0.14 A	360	200	160	120	60
24ESLNX144	0.55 / 0.20 A	144	84	60	48	24
24ESLNX288	0.67 / 0.23 A	288	168	120	96	48
24ESLNX350	0.67 / 0.23 A	350	200	144	120	60
24ESLNX432	0.67 / 0.23 A	432	250	180	140	72

## WIRE GUARDS

460.0034-E	Wall Mount
------------	------------

Project/Location:

Contractor:

Date:

Prepared by:

# ESLNX Series

6, 12 and 24V  
NEMA-4X Rated



## DIMENSIONS

Dimensions are approximate and subject to change.

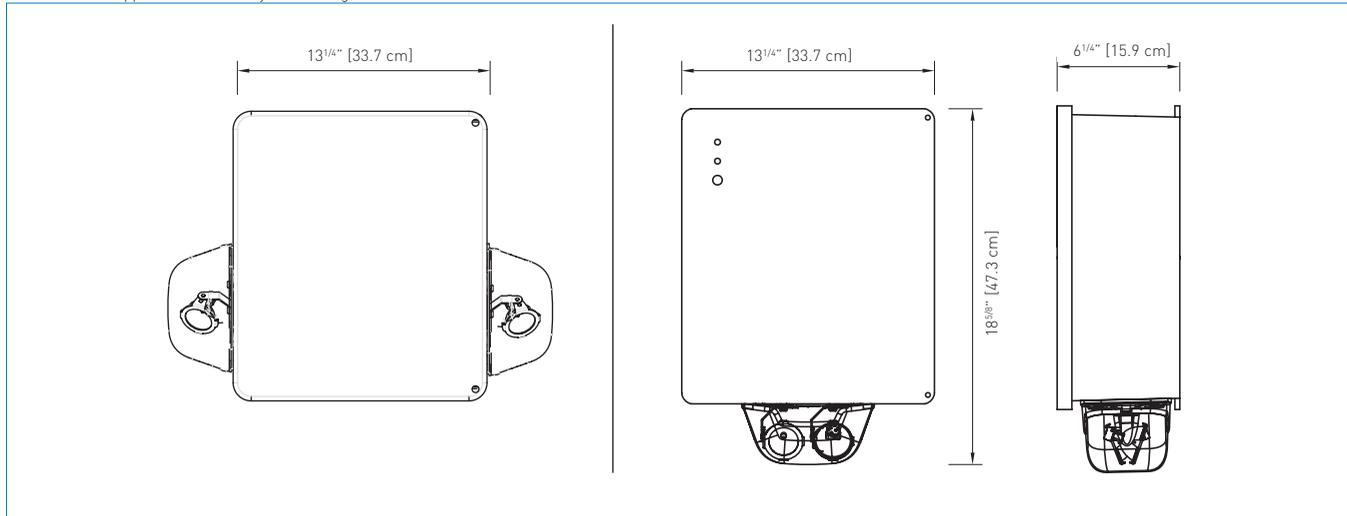

## ORDERING INFORMATION

SERIES	HOUSING	CAPACITY	AC VOLTAGE	OPTIONS	# OF HEADS	LAMPS
06ESL= 6V	NX= NEMA-4X	72= 72W 108= 108W 180= 180W	Blank= 120/347 VAC input -2= 277VAC input	Blank= no options D1= time delay (5 minutes) D2= time delay (10 minutes) D3= time delay (15 minutes) TB= DC terminal block U= auto-diagnostics* UN= auto-diagnostics non audible* NEX= NEXUS® system interface (6, 12 and 24V)** NEXRF= wireless NEXUS® system interface**	/0= no heads /1= single head bottom one lamp /2= double head bottom two lamps /S= no head bottom with single lamp on each side /1S= single head bottom with single lamp on each side /2S= double head bottom with single lamps on each side	MI= MR16, 6V-6W MJ= MR16, 6V-10W MK= MR16, 12V-12W MA= MR16, 12V-20W MD= MR16, 24V-20W MS= MR16, 24V-12W MW= 12V-20W, High output LG= LED, 12V-4W LA= LED, 6V-4W LI= LED, 12V-5W LJ= LED, 12V-6W LL= LED, 24V-4W
12ESL= 12V	NX= NEMA-4X	72= 72W 100= 100W 144= 144W 200= 200W 250= 250W 360= 360W-30min/ 160W-90min				
24ESL= 24V	NX= NEMA-4X	144= 144W 288= 288W 350= 350W 432= 432W				

\*Minimum lamp load required: 20% of unit capacity

\*\* Not all options available with NEXUS®. Please consult your sales representative.

EXAMPLE: 06ESLNX72/BDLA



# 48 Series & FPS Series

Fluorescent Inverters

Project/Location: \_\_\_\_\_

Contractor: \_\_\_\_\_

Date: \_\_\_\_\_

Prepared by: \_\_\_\_\_

## FEATURES

- All FPS Series are fully load tested prior to shipment
- Inverter is 100% solid state, short and open circuit proof
- Polarized DC input (48 Series only)
- 120VAC 60Hz input is standard, 277 and 347VAC available as options
- 25%, 50% or 80% lamp lumen output
- Mounts directly in ballast channel, remote or optional T-Bar fixture
- CSA listed



## TYPICAL SPECIFICATIONS

**48 Series:** The electrical contractor shall supply and install **Emergi-Lite® 48 Series** remote fluorescent inverter ballasts for each fixture as shown on plans. The inverter shall operate on \_\_\_\_\_ VDC input for \_\_\_\_\_ minutes during a power failure. The fluorescent lamp shall be maintained at \_\_\_\_\_ % lumen output for one lamp only. The inverter is to be connected to the remote battery unit as shown on plans (battery unit to be selected according to voltage/wattage and duration required). The inverter shall be capable of illuminating the fluorescent lamp even when it is burned out under normal AC operation.

**FPS Series:** The electrical contractor shall supply and install **Emergi-Lite® FPS Series** fluorescent inverters for each fixture as shown on plans. The **FPS Series** inverter shall operate for \_\_\_\_\_ minutes during a power failure. The fluorescent lamp shall be maintained at \_\_\_\_\_ % of nominal lumen output. The **FPS Series** inverter shall be capable of illuminating the fluorescent lamp even when it is out under normal AC operations.

## DIMENSIONS

Dimensions are approximate and subject to change.

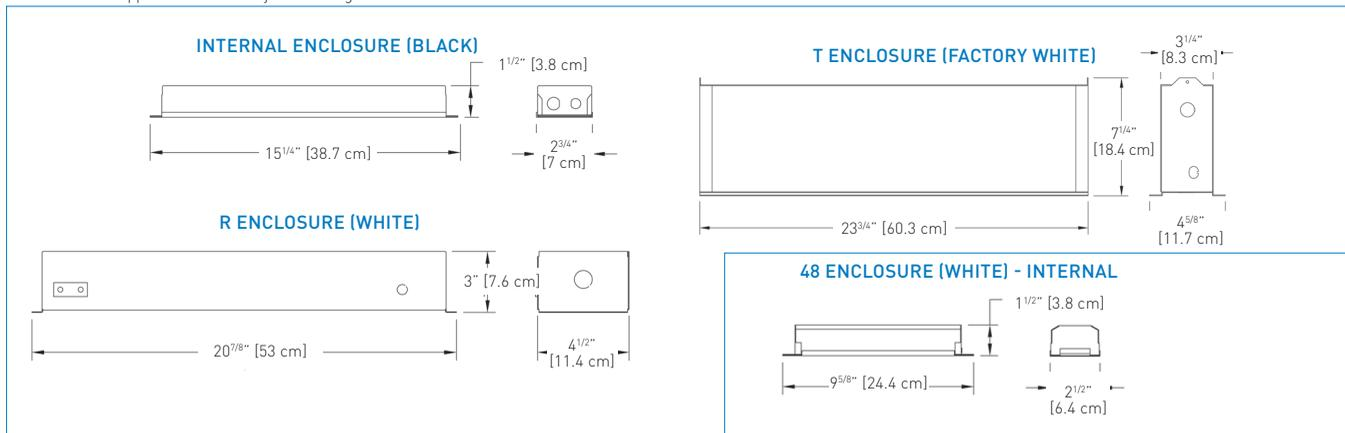

## ORDERING INFORMATION 48 SERIES

48 SERIES	LUMENS / (%) FOR 48" TUBE	VOLTAGE
4806= 6V	25= 25% (800 lumens)	Blank= 120VAC
4812= 12V	Lumen outputs based on averages.	-2= 277VAC
4824= 24V	60= 50% (1600 lumens)	-3= 347VAC
4832= 32V	24"/20W=1260 48"/40W=3200	
4848= 48V	96"/75W=6300	
48120= 120V	100= 80% (2560 lumens)	
	Inverters will operate T12, T8, or "U" type lamps.	

EXAMPLE: 4812-25-3

## D.C. POWER CONSUMPTION

SERIES	OUTPUT %	LUMENS	W
FPS-800	25	800	10
FPS-1600	50	1600	20
FPS-3200	80	2560	32

## ORDERING INFORMATION FPS SERIES

SERIES	LUMENS / (%) FOR 48" TUBE	MIN. RUNTIME	HOUSING	AC VOLTAGE
FPS	25= 25% (800 lumens) Lumen outputs based on averages.	30= 30 minutes 60= 60 minutes 90= 90 minutes 120= 120 minutes*	Blank= internal* R= remote mounting enclosure T= T-Bar	Blank= 120VAC -2= 277VAC -3= 347VAC
	60= 50% (1600 lumens) 24"/20W=1260 48"/40W=3200 96"/75W=6300			
	100= 80% (2560 lumens) Inverters will operate T12, T8, or "U" type lamps.			
		*FPS100 in T-Bar cabinet only.	*Not available for FPS100.	

EXAMPLE: FPS60/30

# Glossary

<b>A</b>	Ammeter	Used to measure the current being supplied to the battery while in charge mode.
<b>U</b>	Auto-Diagnostics	Automatically tests and continuously monitors your emergency lighting unit. If a problem occurs, the unit will send a visual (flashing or blinking LED indicator) and audible warning. Complies with Fire Code requirements.
<b>UN</b>	Auto-Diagnostics, non-audible	Automatically tests and continuously monitors your emergency lighting unit. If a problem occurs, the unit will send a visual (flashing or blinking LED indicator) warning. Complies with Fire Code requirements.
<b>CT</b>	Cab-tire	Unit supplied with a cab-tire cable used for special hardwire applications.
<b>CW1</b>	Cold weather, 120VAC	120VAC input cold weather protection feature for applications where temperatures can reach -40° C.
<b>CW3</b>	Cold weather, 347VAC	347VAC input cold weather protection feature for applications where temperatures can reach -40° C.
<b>FB6</b>	6cct. Fuse panel	Panel used to facilitate the connection of multiple input load circuits in high power battery units.
<b>TX2</b>	Remote test transmitter	Used to perform maintenance tests by means of radio transmitter along with a radio receiver (RRT option) on battery units that are out of reach.
<b>H</b>	Heater & thermostat	Like a heat blanket, used to keep internal temperature optimal for battery units that are installed in cold environments.
<b>L</b>	Line cord (120V)	When ordering a battery unit with the LC option, we supply and pre-install a line cord with a standard 3 prong 120V plug. Just hang the fixture and plug it in to a standard receptacle! Only available on 120V units.
<b>T</b>	Lamp disconnect	To disconnect the emergency lighting load in an area that is not in use during a prolonged power failure or while the area is no longer being occupied.
<b>P</b>	Light activated test switch	Used to remotely test battery units by pointing a flashlight at a photocell mounted on the bottom of a battery unit.
<b>FP</b>	Teflon coated lens	A protective teflon coating that is applied to the glass lens of a lighting fixture to prevent broken shards from falling in the event the glass is accidentally broken or vandalised.
<b>X2</b>	Remote test receiver	Used to perform maintenance tests by means of radio receiver in conjunction with a transmitter (HHC option) on battery units that are out of reach. Simply point the receiver at the unit
<b>NEX</b>	NEXUS® system interface	The NEXUS® system interface is a computerized maintenance system for emergency lighting that, once programmed, will perform the tests, keep written records and send notification if anything needs to be fixed. One full system can address hundreds of units in as many buildings as you need from a single location.
<b>NEXRF</b>	NEXUS® wireless system interface	The NEXUS® wireless system interface is a computerized maintenance system for emergency lighting that, once programmed, will perform the tests, keep written records and send notification if anything needs to be fixed. One full system can address hundreds of units in as many buildings as you need from a single location.
<b>D3</b>	15 minutes time delay	Normally, when the A.C. is restored, all emergency lighting lamps are turned off. However, in some cases such as when metal halide lamps are used, it is possible that the general lighting will not be available for several minutes after the blackout (or brownout) period. Battery units with the T3 option will keep some energy in store to ensure that the emergency lighting stays on or comes back on for at least 15 minutes once the regular A.C. power has been restored.
<b>D</b>	Time delay	Same as the T3 option but can be programmed for 5, 10, 15 or 20 minutes delay.
<b>TP</b>	Tamper-proof screws	Screws that require a special bit. Can be used on certain units to deny access to unauthorized personnel.
<b>LW</b>	Twistlock plug	Used to facilitate the connection and removal of battery units for maintenance purposes.
<b>TBACDC</b>	AC/DC terminal block	Used to facilitate the connection of large gauge input cables.
<b>TB</b>	DC terminal block	Used to facilitate the connection of large gauge D.C. input cables.
<b>TBAC</b>	AC terminal block	Used to facilitate the connection of large gauge A.C. input cables.
<b>V</b>	Voltmeter	Indicates voltage being supplied to the battery when in charge mode.

SURVIVE-ALL  
DISTINCTION

EF9  
RETRACT  
-A-LITE

LITRAY  
EF40

LUX PROVIDER  
-RAY  
EFXPR



# REMOTE FIXTURES

# TABLE OF CONTENTS

							
<b>INTRODUCTION</b>	<b>LUXRAY<sup>MC</sup> LED SERIES</b>	<b>EF40 &amp; EF40P SERIES</b>	<b>RETRACT-A-LITE SERIES</b>	<b>MINI RETRACT-A-LITE SERIES</b>	<b>LITERAY SERIES</b>	<b>EF9 / EF9Q / EF9M SERIES</b>	<b>EF15 SERIES</b>
P. 136-137	P. 138	P. 139	P. 140	P. 141	P. 142	P. 143	P. 144
							
<b>EF18 / EF18D / EF18T SERIES</b>	<b>DISTINCTION<sup>MC</sup> SERIES</b>	<b>DISTINCTION<sup>MC</sup> EFR SERIES</b>	<b>SURVIVE-ALL<sup>MC</sup> EF39 &amp; EF39P SERIES</b>	<b>EF25 SERIES</b>	<b>EF26 / EF26DS / EF26D SERIES</b>	<b>EF11 SERIES</b>	<b>EF30 SERIES</b>
P. 145	P. 146	P. 147	P. 148-149	P. 150	P. 151	P. 152	P. 153
							
<b>EF41 SERIES</b>	<b>EFXPR SERIES</b>	<b>LAMP CHARTS</b>	<b>GLOSSARY</b>				
P. 154	P. 155	P. 156-158	P. 159				

# REMOTE HEADS OVERVIEW

## EMERGENCY LIGHTING HEADS: PERFORMANCE & TECHNOLOGY

**Emergency Lighting Heads represent a key element of an emergency lighting system performance. During a power failure, these lamp heads must provide adequate lighting levels for safe evacuation.**

What level of illumination is necessary to ensure safe evacuation? Minimum levels are established by the National Building Code of Canada:

"3.2.7.3. Emergency Lighting

- 1 - Emergency lighting shall be provided to an average level of illumination not less than 10 lx at floor or tread level
- 2 - Emergency lighting to provide an average level of illumination of not less than 10 lx at floor or catwalk level shall be included in a service space referred to in Sentence 3.2.1.1.7).
- 3 - The minimum value of the illumination required by Sentences (1) and (2) shall not be less than 1 lx."

You have probably already noticed the short lamp life of these light sources. Who would be interested in using a bulb that only lasts 50 hours? The answer is simple: such a lamp produces 25% to 30% more light than a lamp of the same wattage but longer lamp life (i.e. 1,000 hours). By design, the filament in an emergency lighting head is used at higher temperatures, increasing light output.

During a power failure, the emergency power supply is provided to the heads from batteries. Equipment manufacturers and customers should use high intensity light sources, with efficient light levels and distributions.

## MINIATURE LAMPS: TUNGSTEN AND QUARTZ HALOGEN

Most commonly used emergency lighting heads are fabricated of an injection-molded thermoplastic housing containing a miniature lamp, a metallic reflector and a polycarbonate lens. Lamps use a tungsten filament enclosed in a filling gas mixture of argon and nitrogen and are generally referred to as incandescent lamps.

Better performance is obtained with quartz halogen lamps, which are still incandescent lamps, but the filling gas (iodide/chloride) allows the tungsten filament to operate at higher temperatures. This results in higher luminous intensity, 20 to 30% superior to standard incandescent lamps of the same wattage and lamp life.

However, using high temperatures also increases vaporization of the filament which shortens its life. As power failures are relatively scarce (let's say 4 to 6 per year) and duration of emergency lighting between 30 minutes to 2 hours, lamp heads are only used between 3 to 12 hours per year. A lamp with an average life of 50 hours should therefore be functional for over four years.

Lamp manufacturers offer two types of miniature lamps: long life and high light output.

## PAR36 SEALED BEAM LAMPS

Emergency head performance also depends on lamp optics: the reflector and the lens. This is especially critical in damp areas where vapors and water condensation can deteriorate the electrical contacts and the reflector performance. Sealed beam lamps are recommended for such applications.

Sealed beam lamp construction includes a metal coated glass reflector and a lens, designed to provide a light beam of a certain opening: narrow, medium, large, etc. The most common lamps used are those with a 4.5" diameter (PAR36), available in both incandescent and halogen versions. As to miniature lamps, there are sealed beam lamps dedicated to long life applications (4,000 hours, 7-8 lumens/Watt) and for emergency lighting (50 to 300 hours, 12-20 lumens/Watt).

Originally, lamp life wasn't an issue. However, this has become increasingly important in recent years, with the introduction of sophisticated emergency lighting fixtures with periodic self-test and self-diagnostic features. Such a system includes a micro-controller board that automatically simulates a power failure and forces the fixture in emergency lighting mode every 30 days for at least 30 seconds and tests both the batteries and the lamps. Even if the duration of the self-test is minimal compared to the lamp life, the repetitive connection and disconnection cycle of the lamps increases the risk of a premature failure caused by the initial high current applied.

## MR16 GENERATION

Fortunately, the lamp life issue was resolved with a new generation of lamps that use MR16 technology (MR16 stands for Multi-faceted Reflector, 16/8" diameter). Increasingly popular, the MR16 contains everything in one: miniature halogen lamp, metal coated glass reflector and, for the most part, a glass lens cemented to the reflector. Easy to install, MR16 lamps are popular in both residential and commercial applications, and increasingly specified for emergency lighting.

In addition to their bright directional beam, these lamps offer good efficacy (11 to 18 lumens/Watt), as well as long life (2,000 to 6,000 hrs). First, the use of a glass lens which is clear and thin, allows the MR16 to absorb much less light than a standard diffuser lens; and second, efficient light distribution is accomplished by the multi-faceted reflector.

## 200-LUMEN 4W MR16 LED

Leading the technology trend, **Emergi-Lite®** offers a complete series of 4W MR16 LED lamps available for all the standard battery voltages: 6V, 12V, 24V and 120V. With up to 30,000 hours of operational life and a luminous flux of typically 200 lumens, they are available with most emergency heads designed to hold an MR16 lamp and meet the majority of illumination specifications. For example: one pair of LED emergency heads installed at a height of 7.5ft, illuminates a 6ft by 40ft path of egress. Compared to halogen lamps (16-20W), these 4W MR16 LED lamps illuminate the same area of egress during an emergency situation by using 75% less power. This has a direct impact on the battery size, reducing the back-up capacity needs by 75%. Consequently, it also reduces the total cost of the application, with the use of smaller battery capacity units, the possibility of using fewer fixtures due to superior illumination, thus also reducing electrical wiring, and it reduces the environmental footprint.

### 340-LUMEN 5W MR16 LED

Keeping pace with technology, in 2012 we introduced a 12V-5W MR16 LED lamp. With a typical luminous flux of 340 lumens, this lamp has the same lighting performance as a 20W high-output halogen MR16. A twin emergency head installed at a height of 7.5ft illuminates more than a 70ft path of egress.

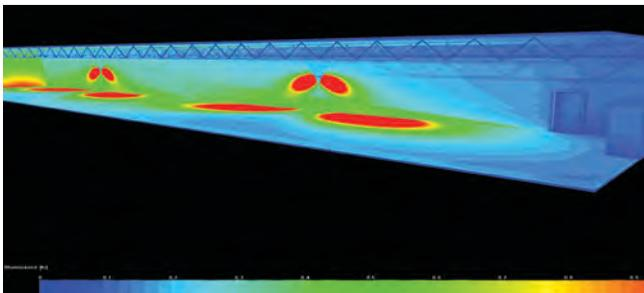
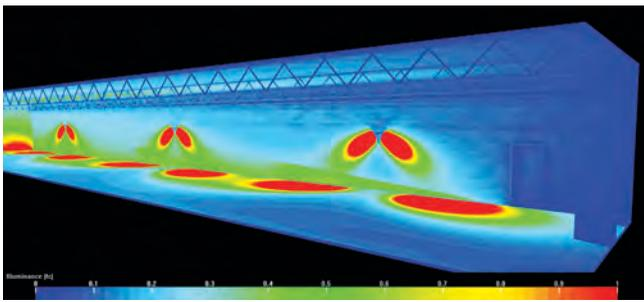
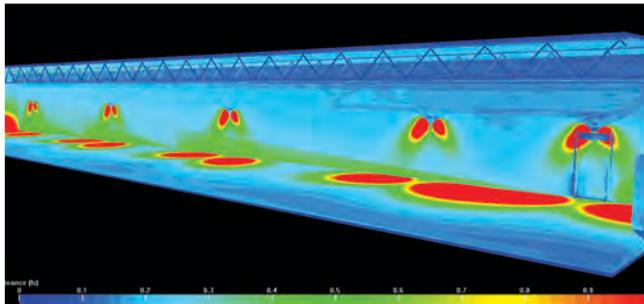
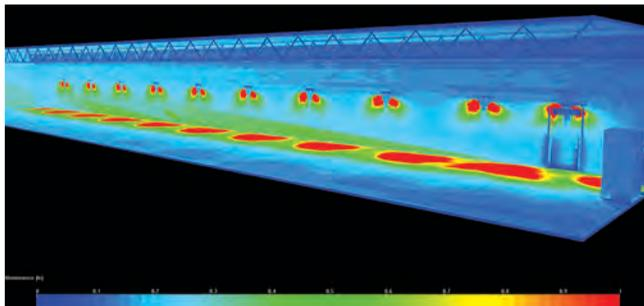

### 510-LUMEN 6W MR16 LED

New in Fall 2013, we introduce a 12V - 6W MR16 LED lamp, which offer typical luminous flux of 510 lumens. Like the lower wattage MR16 LED lamps, this new lamp is specially designed for emergency lighting. It offers the same lighting performance as the 35W or 20W Mr16 IR. A twin emergency head installed at a height of 7.5' illuminates approximately 100' path of egress.

### STANDARD WEDGE-BASE 9W INCANDESCENT LAMP

Standard Emergency Lighting Units with 9W wedge-base incandescent lamps

### 4W MR16 LED LAMPS

Same Standard Emergency Lighting Units with 4W MR16 LED Lamps

LAMP SUFFIX	VOLTAGE	WATTAGE	LUMENS	REPLACEMENT #
LA	6	4	130	580.0097-E
LG	12	4	170	580.0093-E
LL	24	4	200	580.0098-E

### 5W MR16 LED LAMP

LAMP SUFFIX	VOLTAGE	WATTAGE	LUMENS	REPLACEMENT #
LI	12	5	340	580.0104-E

### NEW! 6W MR16 LED LAMPS

LAMP SUFFIX	VOLTAGE	WATTAGE	LUMENS	REPLACEMENT #
LJ	12	6	510	580.0106-E



# Remote Fixture Lux-Ray™ LED Series

Rugged, Versatile, Sophisticated

Project/Location:	_____
Contractor:	_____
Date:	_____
Prepared by:	_____

## FEATURES

- Four-LED light engine with redundant connections
- Powder-coated Die-Cast aluminum construction
- Clear Polycarbonate lens allows for maximum lumen output
- Surface Wall Mount
- Certified to the CSA 22.2 No.141 standard
- NEMA-3R Damp and Wet locations
- Operating temperature -40°C to + 50°C

## OPTIONS

- Forward-throw light distribution
- Dual-mode: normal and emergency LED lighting
- High-lumen output
- Photo-switch: dusk-to-dawn control of normal lighting
- Infrared remote control (normal lighting)



## POWER CONSUMPTION

MODEL TYPE	AC SPECS: 120/347VAC				6-12VDC REMOTE
	NORMAL LIGHTING		EMERGENCY LIGHTING		
	CURRENT (MAX)	POWER (MAX)	CURRENT (MAX)	POWER (MAX)	
AC, ACDC, DC	0.12/0.05 A	12W	0.12/0.05 A	12W	8W
AC, ACDC, DC -H	0.18/0.07 A	18W	0.18/0.07 A	18W	14W
2AC (120VAC only)	0.12 A	12W	0.12 A	12W	-
2AC-H (120VAC only)	0.18 A	18W	0.18 A	18W	-

\*Note: Only unswitched AC input; normal lighting with photo-switch or remote control

## DIMENSIONS

Dimensions are approximate and subject to change.

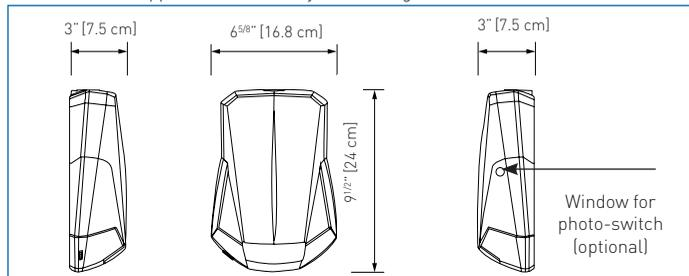

## TABLE A: SPACING FOR AVERAGE 1FC

MODEL TYPE	MOUNTING HEIGHT	WATTAGE CAPACITY	
		SINGLE	CENTRE-TO-CENTRE
Standard	9'	6' X 50'	6' X 50'
With option -H	11'	6' X 60'	6' X 60' 3' X 70'
With option -FT	12'	6' X 40'	-
With option -FTH	15'	6' X 50'	-

Indoor reflectance: 80/50/20 and 10-ft wide corridor.  
Outdoor reflectance: 0/30/10

Note: The illumination level meets ALL the requirements of the National Building Code-Canada and the Life Safety Code (NFPA 101):

- 1) Average of 1 foot-candle (10.7 lux) or more
- 2) Minimum at any point of 0.1 foot-candle (1.07 lux) or more
- 3) Maximum-to-minimum illumination uniformity ratio of 40:1 or less

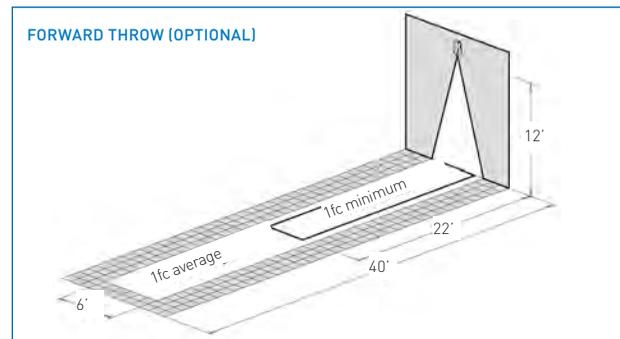
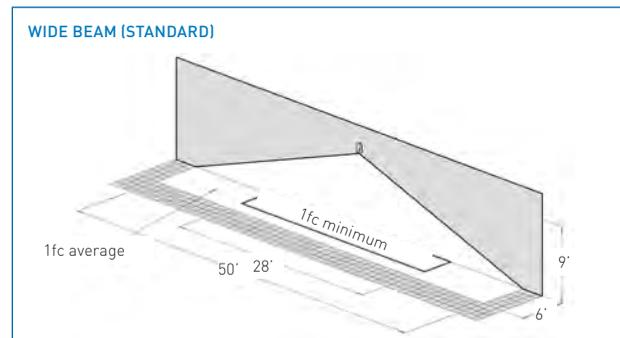

## ORDERING INFORMATION

SERIES	FUNCTION: REMOTE FIXTURES (-40... +50°C)	COLOUR	OPTION
LUX= Lux-Ray™ LED	AC= AC-only ACDC= AC/6-12VDC remote DC= 6-12VDC remote fixture 2AC= AC-only two circuits: 120/120 or 277/277V	OW= off-white BK= black DB= dark bronze PG= platinum grey	-FT= Forward throw lighting -H= High lumen output (max. 30°C) -P= Photo-switch, normal lighting (models AC, ACDC only) -RC= Remote control - infrared (models AC, ACDC only)* -2= 277VAC 60Hz input  * Remote control keypad (TB-RC1-E) ordered separately

EXAMPLE: LUXACDCBK-H-P

Project/Location: \_\_\_\_\_

Contractor: \_\_\_\_\_

Date: \_\_\_\_\_

Prepared by: \_\_\_\_\_

# EF40 & EF40P Series

Remote Fixture



## FEATURES

- Quality illumination requires fewer fixtures
- Clear polycarbonate UV and impact resistant lens with optional tamper-proof screws to prevent tampering.
- Easy lamp replacement
- CSA certified to C22.2 No. 141
- Modern design will blend into surroundings
- Selection of Die-Cast or polycarbonate back plate
- For indoor use only

## DIMENSIONS

Dimensions are approximate and subject to change.

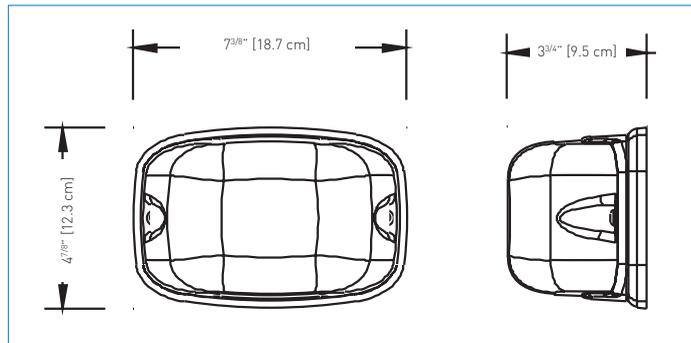

## TYPICAL SPECIFICATIONS

Supply and install **Emergi-Lite® EF40P Series** remote emergency lighting. These remote fixtures will consist of either single or double lamp configurations as specified and include a UV resistant fire retardant polycarbonate back plate and a clear heavy-duty UV resistant polycarbonate light cover.

The remote fixture shall be certified to CSA C22.2 No. 141.

The head(s) shall be fully adjustable and be equipped with high efficiency MR16 halogen or LED lamp(s) of \_\_\_\_\_ V, \_\_\_\_\_ W.

The remote unit shall be **Emergi-Lite®** model: \_\_\_\_\_.

## WIRE GUARDS

460.0029-E	Wall Mount
------------	------------

## REPLACEMENT LAMPS: MR16 EF40P

ORDERING CODE	LAMP TYPE	VOLTAGE
580.0074-E	MR16 flood	6V-6W
580.0079-E	MR16 flood	6V-10W
580.0080-E	MR16 flood	12V-12W
580.0070-E	MR16 flood	24V-12W
580.0097-E	MR16 LED	6V-4W
580.0093-E	MR16 LED	12V-4W
580.0104-E	MR16 LED	12V-5W
580.0106-E	MR16 LED	12V-6W
580.0098-E	MR16 LED	24V-4W

For the complete list, please see the lamp chart on pages 156 to 158

## REPLACEMENT LAMPS: MR16 EF40

ORDERING CODE	LAMP TYPE	VOLTAGE
580.0068-E	MR16 infrared	12V-20W
580.0077-E	MR16 flood	24V-20W

## ORDERING INFORMATION: EF40P

SERIES	NUMBER OF LAMPS	LAMP TYPE	COLOUR	LAMP TYPE/VOLTAGE/WATTAGE	OPTIONS
EF40P= polycarbonate	Blank= one lamp D= two lamps	M= MR16	Blank= factory white B= black G= grey	6V6W= MR16, 6V-6W 6V10W= MR16, 6V-10W 12V12W= MR16, 12V-12W 24V12W= MR16, 24V-12W LA= MR16 LED 6V-4W LG= MR16 LED 12V-4W LI= MR16 LED 12V-5W LJ= MR16 LED 12V-6W LL= MR16 LED 24V-4W	Blank= no option T= tamper-proof screws*  *Tamper-proof bit for dry location Part No. 690.0454-E (one bit needed per order)

## ORDERING INFORMATION: EF40

SERIES	NUMBER OF LAMPS	LAMP TYPE	COLOUR	LAMP TYPE/VOLTAGE/WATTAGE	OPTIONS
EF40 = Die-Cast backplate	Blank= one lamp D= two lamps	M= MR16	Blank= factory white B= black G= grey	12V20W = MR16IR, 12V-20W 24V20W = MR16, 24V-20W	Blank= no option T= tamper-proof screws*  *Tamper-proof bit for dry location Part No. 690.0454-E (one bit needed per order)

EXAMPLE: EF40PDM-B-6V6WT

# Retract-a-Lite™ Series

## Remote Fixture

Project/Location: \_\_\_\_\_

Contractor: \_\_\_\_\_

Date: \_\_\_\_\_

Prepared by: \_\_\_\_\_

### FEATURES

- Remote only visible upon power failure
- Front can be painted or wallpapered on-site to match existing decor
- Fully automatic operation: The unit door opens upon supply with DC voltage from battery and closes after voltage disconnect. Time delay option required on battery unit to properly close the door
- AC line voltage not required
- Emergency lights: Two high efficacy MR16 halogen or MR16 LED lamps
- Certification: CSA C22.2 No.141

### DIMENSIONS

Dimensions are approximate and subject to change.

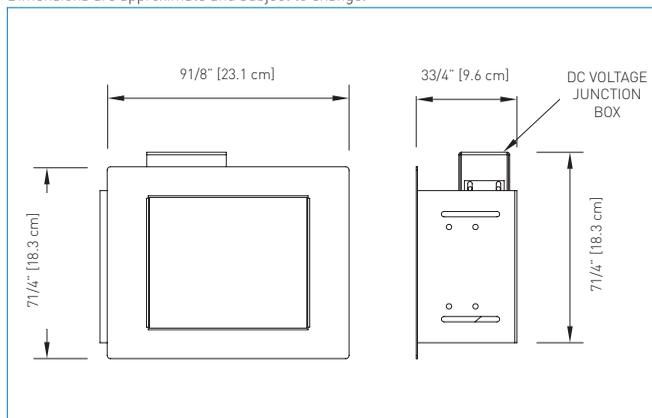

### WIRE GUARDS

460.0082-E	Wall Mount
------------	------------

### TYPICAL SPECIFICATIONS

Supply and install **Emergi-Lite® Retract-a-Lite™ Series** of remote fixture: The unit shall be designed to be concealed in walls or ceilings with a cavity. The unit equipment shall be completely concealed in the wall or ceiling in the absence of remote power. Upon DC power supply the unit will rotate its door by 180° to expose the emergency lamps, and power them. After the DC power disconnect the lamps will turn off and the unit will conceal the heads by rotating the door by 180°. The DC-remote unit shall not require the presence of AC power in order to open or close the door.

Under normal conditions, the only visible parts of the unit shall be the off-white flat door and trim plate that can be customized on site with paint or other suitable wall covering. The light source shall be MR16 halogen lamps of specified wattage and light output.

The remote unit shall be the **Emergi-Lite®** model: \_\_\_\_\_.

### REPLACEMENT LAMPS: MR16

MODEL	LAMP TYPE	VOLTAGE/WATTAGE
580.0080-E	MR16 12W Flood	12V-12W
580.0064-E	MR16 20W Flood	12V-20W
580.0083-E	MR16 35W Flood	12V-35W
580.0076-E	MR16 50W Flood	12V-50W
580.0068-E	MR16 IR 20W Flood	12V-20W High-output
580.0090-E	MR16 IR 35W Flood	12V-35W High-output
580.0089-E	MR16 IR 50W Flood	12V-50W High-output
580.0084-E	MR16	24V-35W
580.0070-E	MR16	24V-12W
580.0077-E	MR16	24V-20W
580.0078-E	MR16	24V-50W
580.0093-E	MR16 LED	12V-4W
580.0098-E	MR16 LED	24V-4W
580.0104-E	MR16 LED	12V-5W
580.0106-E	MR16 LED	12V-6W

For the complete list, please see the lamp chart on pages 156 to 158

### ORDERING INFORMATION

SERIES	WATTAGE FOR EACH OF THE 2 LAMPS	OPTIONS
12RTL= 12VDC remote 24RTL= 24VDC remote	-12= MR16, 12W -20= MR16, 20W -35= MR16, 35W -50= MR16, 50W -20H= MR16, High lumen output, 20W -35H= MR16, High lumen output, 35W -50H= MR16, High lumen output, 50W -LG= MR16 LED, 12V-4W -LI= MR16 LED, 12V-5W -LL= MR16 LED, 24V-4W -LJ= MR16 LED, 12V-6W	<b>TB</b> = T-Bar mounting kit
Note: The remote fixture is compatible with all Retract-a-Lite™ battery units		

EXAMPLE: 12RTL-20TB

Project/Location:

Contractor:

Date:

Prepared by:

# Mini Retract-a-Lite™ Series

For AC Power Generator



## FEATURES

- Easy to retrofit in finished walls: the unit slides in through an 8.25" by 5.75" hole
- No back-box needed to pre-install
- Output: 12VDC with up to 100W of power
- Direct connection to 120 or 347VAC power generators
- Emergency lights: MR16 halogen and MR16 LED lamps
- Certification: CSA C22.2 No. 141

## DIMENSIONS

Dimensions are approximate and subject to change.

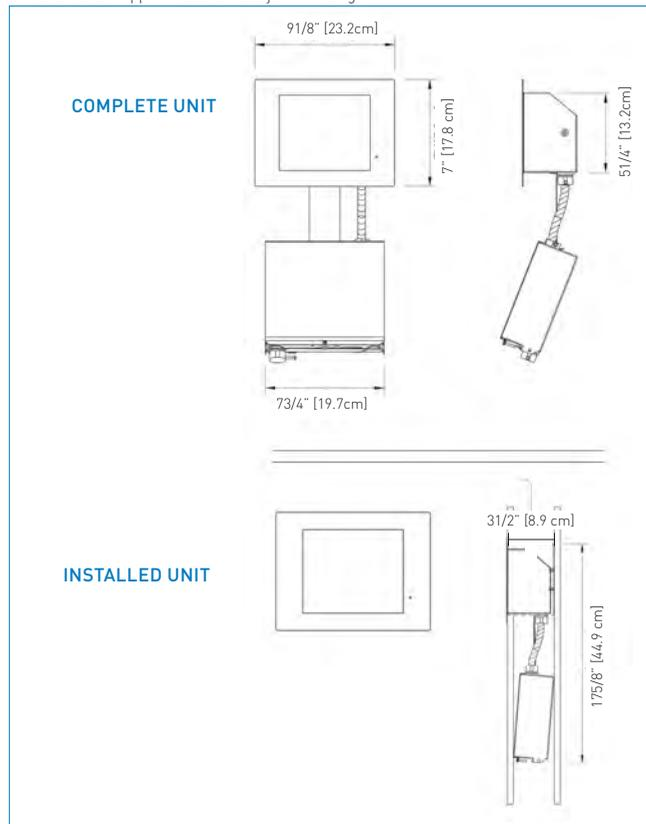

## TYPICAL SPECIFICATIONS

Supply and install **Emergi-Lite® Series Mini Retract-a-Lite™**. The unit shall be designed to be completely concealed in walls with a cavity. The equipment shall consist of a metal housing containing two modules joined by a flexible bracket and electric conduit. One module contains the power transformer and electrical connection box; the other module contains the emergency lights installed on the back of a door able to rotate several turns of 360°. The unit equipment shall be completely concealed in the wall, after the installation through a rectangular opening not larger than 8.25" by 5.75".

In stand-by mode, the only visible parts of the unit shall be the off-white flat door and trim plate that can be customized on site with paint or other suitable wall covering. Upon AC power supply the unit will expose the emergency heads by rotating its door 180° and then will power the lamps. At the end of the AC power, the lamps will turn off and the unit will retract the heads by rotating the door 180° in the same direction.

The unit shall not require the presence of AC power in order to close the door and conceal the lights. The door of the unit shall be easy to force-turn (open or close) by hand. The light source shall be 12V MR16 halogen lamps of specified wattage and light output.

The remote unit shall be the **Emergi-Lite®** model: \_\_\_\_\_



## REPLACEMENT LAMPS

MODEL	TYPE	VOLTAGE/WATTAGE
580.0080-E	MR16 flood	12V-12W
580.0064-E	MR16 flood	12V-20W
580.0083-E	MR16 flood	12V-35W
580.0076-E	MR16 flood	12V-50W
580.0068-E	MR16 IR flood	12V-20W High output
580.0090-E	MR16 IR flood	12V-35W High output
580.0089-E	MR16 IR flood	12V-50W High output
580.0093-E	MR16 LED	12V-4W
580.0104-E	MR16 LED	12V-5W
580.0106-E	MR16 LED	12V-6W

For the complete list, please see the lamp chart on pages 156 to 158

## ORDERING INFORMATION

SERIES	UNIT CAPACITY	AC VOLTAGE	LAMP WATTAGE (12V MR16)
MR	G= remote AC generator, maximum 100W	Blank= 120VAC 2= 277VAC 3= 347VAC	/12= MR16, 12W /20= MR16, 20W /35= MR16, 35W /50= MR16, 50W /20H= MR16, High lumen output, 20W /35H= MR16, High lumen output, 35W /50H= MR16, High lumen output, 50W /LG= MR16 LED, 12V-4W /LI= MR16 LED, 12V-5W /LJ= MR16 LED, 12V-6W

EXAMPLE: MRL80/20HUN

Note: Testing requires minimum 5 seconds of power supply.



# Literay Series

Wall Mounted  
Remote Head

Project/Location: \_\_\_\_\_

Contractor: \_\_\_\_\_

Date: \_\_\_\_\_

Prepared by: \_\_\_\_\_

## FEATURES

- Outdoor/Indoor installation
- Compact wall sconce unit for indoor and outdoor use
- High impact resistant polycarbonate diffuser
- Adjustable lamps
- Die-Cast aluminum housing
- Vandal resistant option
- CSA Certified to C22.2 No. 141

## WIRE GUARDS

460.0082-E	Wall Mount
------------	------------



## TYPICAL SPECIFICATIONS

Wall mount unit shall be gasketed Die-Cast aluminum housing, impact resistant polycarbonate diffuser. The lamps shall be adjustable for aisle or area distribution.

Fixture shall be supplied with gasket and shall be suitable for installation on any four inch octagonal box.

The remote unit shall be **Emergi-Lite®** model: \_\_\_\_\_.

## REPLACEMENT LAMPS

MODEL	LAMP TYPE	VOLTAGE/WATTAGE
580.0079-E	MR16 Flood	6V-10W
580.0080-E	MR16 Flood	12V-12W
580.0068-E	MR16 Flood	24V-20W
580.0077-E	MR16 Flood	24V-20W
580.0070-E	MR16 Flood	24V-12W
580.0097-E	MR16 LED	6V-4W
580.0093-E	MR16 LED	12V-4W
580.0104-E	MR16 LED	12V-5W
580.0098-E	MR16 LED	24V-4W
580.0106-E	MR16 LED	12V-6W

For the complete list, please see the lamp chart on pages 156 to 158

## DIMENSIONS

Dimensions are approximate and subject to change.

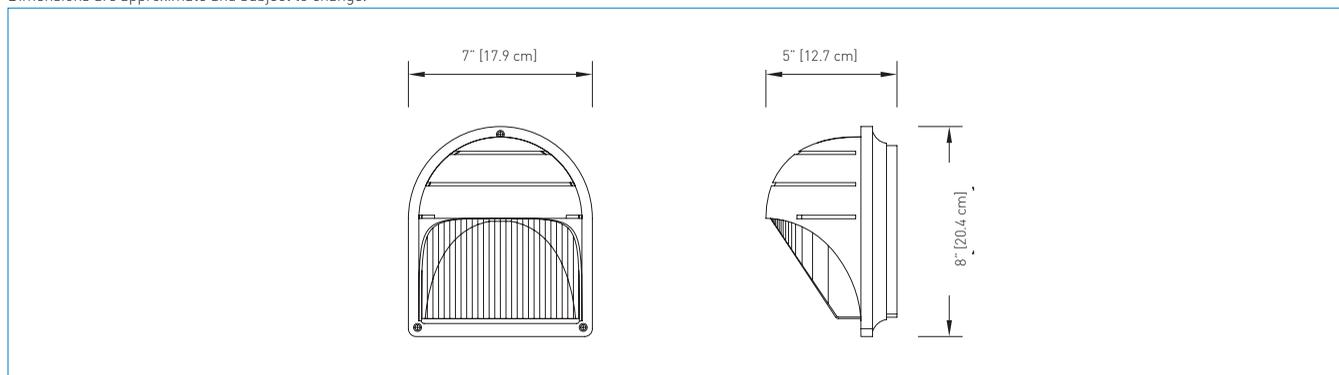

## ORDERING INFORMATION

SERIES	LAMP TYPE	COLOUR	VOLTAGE/ WATTAGE	OPTIONS
EF33= exterior remote	<b>Blank</b> = (1) med. base socket only (max. 60W) no lamp included <b>M</b> = MR16	<b>Blank</b> = factory white <b>B</b> = black <b>DG</b> = dark grey <b>BZ</b> = dark bronze	<b>Blank</b> = no lamps <b>-6V10W</b> = MR16, (2) 6V-10W <b>-12V12W</b> = MR16, (2) 12V-12W <b>-12V20W</b> = MR16, (2) 12V-20W <b>-24V12W</b> = MR16, (2) 24V-12W <b>-24V20W</b> = MR16, (2) 24V-20W <b>-12V20WH</b> = MR16, (2) 12V-20W high-output <b>-LA</b> = MR16 LED, 6V-4W <b>-LG</b> = MR16 LED, 12V-4W <b>-LL</b> = MR16 LED, 24V-4W <b>-LI</b> = MR16 LED, 12V-5W <b>-LJ</b> = MR16 LED, 12V-6W	<b>-VR</b> = vandal resistant screws <b>990.0119-E</b> = tamper-proof bit* <b>C</b> = clear lens  *One bit needed per order.

EXAMPLE: EF33M-12V12W

Project/Location: \_\_\_\_\_

Contractor: \_\_\_\_\_

Date: \_\_\_\_\_

Prepared by: \_\_\_\_\_

# EF9/EF9Q/EF9M Series

Micro Tungsten Lamps,  
Micro-Quartz Lamps,  
MR16 Lamps, or LED



## FEATURES

- Available with tungsten, micro-quartz MR16 or LED lamps
- Fire-retardant thermoplastic
- 300° rotation
- CSA certified to C22.2 No. 141
- 6, 12 and 24V with various wattages



## DIMENSIONS

Dimensions are approximate and subject to change.

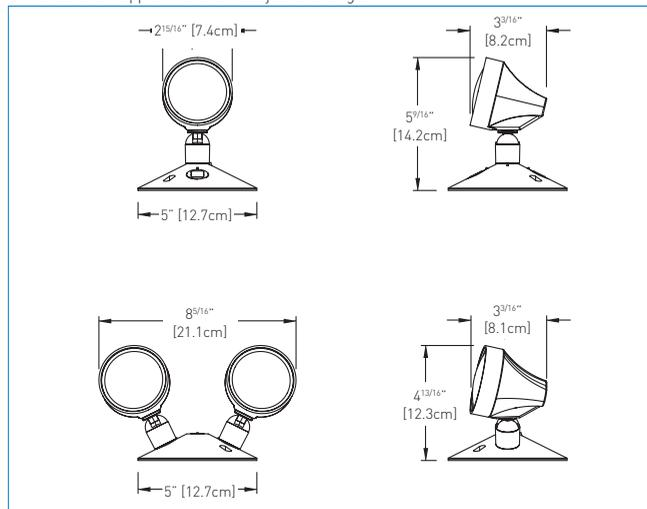

## TYPICAL SPECIFICATIONS

Lamp head and stem shall be injection molded, impact resistant, flame retardant thermoplastic and shall require no tool for aiming or adjustment. The lens shall be inverse concave design and fully adjustable for aisle or area distribution during installation without the need to energize the lamp. Visual identification of distribution shall be provided through position of adjustment pins.

Fixture shall be supplied with a canopy for installation on any four inch octagon box. Housing shall be designed to allow for lamp replacement if required.

The remote unit shall be the **Emergi-Lite®** model: \_\_\_\_\_.

## WIRE GUARDS

460.0029-E	Wall ceiling Mount
------------	--------------------

## REPLACEMENT LAMPS

MODEL	AC SPECS	DC SPECS
570.0016-E	Tungsten	6V-9W
570.0045-E	Tungsten	24V-9W
570.0015-E	Halogen (quartz)	12V-12W
570.0097-E	MR16 LED	6V-4W
570.0093-E	MR16 LED	12V-4W
570.0104-E	MR16 LED	24V-4W
570.0098-E	MR16 LED	12V-5W
570.0106-E	MR16 LED	12V-6W

For the complete list, please see the lamp chart on pages 156 to 158

## ORDERING INFORMATION

SERIES	NUMBER OF LAMPS	LAMP TYPE	COLOUR	VOLTAGE/WATTAGE
EF9= mini, PAR 18	Blank= single head D= double head T= triple head	Blank= tungsten, wedge base Q= halogen, quartz bi-pin M= halogen, MR16 LED	Blank= factory white -B= black	-6V9W= 6V-9W, wedge base -12V9W= 12V-9W, wedge base -12V18W= 12V-18W, wedge base -24V9W= 24V-9W, wedge base -24V18W= 24V-18W, wedge base -6V8W= 6V-8W, quartz bi-pin -6V12W= 6V-12W, quartz bi-pin -12V8W= 12V-8W, quartz bi-pin -12V12W= 12V-12W, quartz bi-pin -6V6W= MR16, 6V-6W -6V10W= MR16, 6V-10W -12V12W= MR16, 12V-12W -12V20W= MR16, 12V-20W -24V12W= MR16, 24V-12W -24V20W= MR16, 24V-20W -LI= MR16 LED, 12V-5W -LG= MR16 LED, 12V-4W -LA= MR16 LED, 6V-4W -LL= MR16 LED, 24V-4W -LJ= MR16 LED, 12V-6W

EXAMPLE: EF9Q6V8W



# Recess Mounted EF15 Series

Compact Emergency Lighting

Project/Location: \_\_\_\_\_

Contractor: \_\_\_\_\_

Date: \_\_\_\_\_

Prepared by: \_\_\_\_\_

## FEATURES

- Durable thermoplastic trim (metal trim as an option)
- PAR 36 Gimbal ring adjustable on two planes to 45°
- Complete unit, no additional housing needed
- Certified CSA C22.2 No.141



## DIMENSIONS

Dimensions are approximate and subject to change.

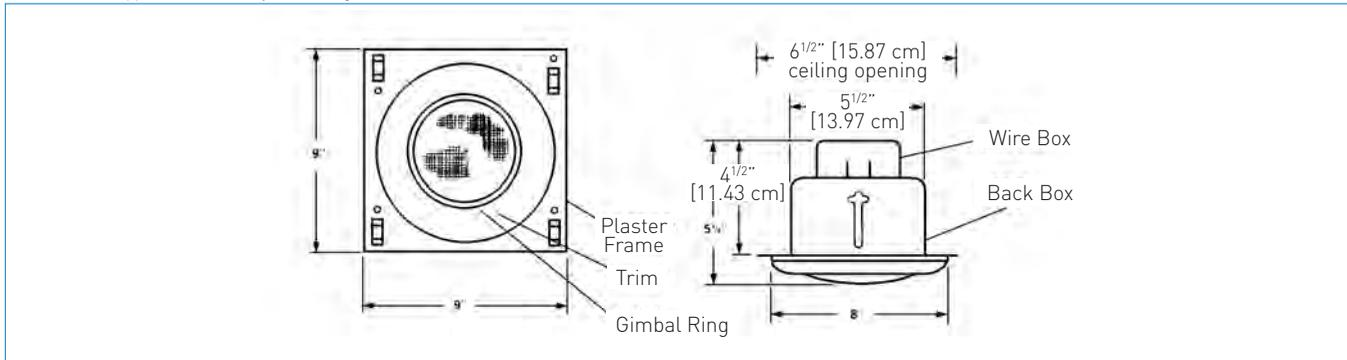

## WIRE GUARDS

460.0033-E	Wall or ceiling mount
------------	-----------------------

## REPLACEMENT LAMPS

MODEL	LAMP TYPE	VOLTAGE/WATTAGE
570.0026-E	Tungsten	6V-9W
570.0025-E	Tungsten	12V-9W
570.0045-E	Tungsten	24V-9W

For the complete list, please see the lamp chart on pages 156 to 158

## ORDERING INFORMATION

SERIES	LAMP TYPE	HOUSING	COLOUR	VOLTAGE/ WATTAGE/ LAMP TYPE
EF15= PAR 36 recessed with plastic trim	Blank= tungsten H= quartz sealed beam Q= halogen S= sealed beam	Blank= plastic trim M= metal trim	Blank= factory white BK= black	-6V9W= tungsten, 6V - 9W, wedge base -6V__W= tungsten, 6V - 18 or 25W, D.C.B. -12V__W= tungsten, 12V - 9 or 18W, wedge base -12V25W= tungsten, 12V - 25W, D.C.B. -24V__W= tungsten, 24V - 9 or 18W, wedge base -24V25W= tungsten, 24V - 25W, D.C.B. -6V__W= halogen, 6V - 8, 12 or 20W, quartz bi-pin -12V__W= halogen, 12V - 8, 12, 20 or 55W, quartz bi-pin -24V__W= halogen, 24V - 20 or 70W, quartz bi-pin -6V__W= tungsten, 6V - 9, 12, 18 or 25W, sealed beam -12V__W= tungsten, 12V - 12, 18 or 25W, sealed beam -6V__W= halogen, 6V - 8, 12 or 20W, quartz sealed beam -12V__W= halogen, 12V - 8, 12 or 37W, quartz sealed beam -32V__W= tungsten, 32V - 18 or 25W, D.C.B. -120V__W= 120V - 10 or 15W, D.C.B. -120V__W= quartz, 120V - 35 or 50W, D.C.B.

\* Available with metal trim only.  
NOTE : "\_\_\_" insert wattage required

EXAMPLE: EF15Q-12V12W

Project/Location: \_\_\_\_\_

Contractor: \_\_\_\_\_

Date: \_\_\_\_\_

Prepared by: \_\_\_\_\_

# EF18/EF18D/ EF18T Series

Surface Mounted,  
Remote Fixture



## FEATURES

- PAR 36, surface-mounted, large remote fixtures
- Single, double or triple head
- Positive aim swivel
- CSA certified to C22.2 No. 141



## REPLACEMENT LAMPS

MODEL	LAMP TYPE	VOLTAGE/WATTAGE
570.0016-E	Mini tungsten, wedge base	6V-9W
570.0025-E	Mini tungsten, wedge base	12V-9W
580.0023-E	Mini halogen (quartz), bi-pin	24V-20W

For the complete list, please see the lamp chart on pages 156 to 158

## TYPICAL SPECIFICATIONS

Base and remote head are injection-molded thermoplastic, shockproof and flame retardant. Shall be supplied factory white or black. The setting point shall provide visual indication of the light distribution.

The fixture shall be supplied with a canopy to be installed on any standard octagonal box. The housing shall be designed to allow lamp replacement when required.

The remote unit shall be the **Emergi-Lite®** model: \_\_\_\_\_

## WIRE GUARDS

470.0035-E	Wall Mount (EF18)
470.0082-E	Wall Mount (EF18D)
470.0078-E	Wall Mount (EF18T)

## DIMENSIONS

Dimensions are approximate and subject to change.

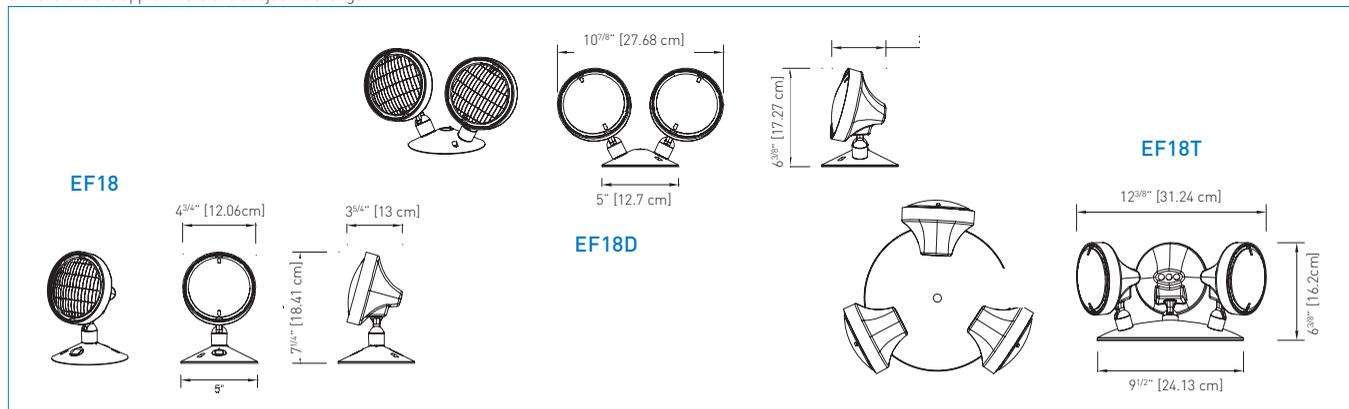

## ORDERING INFORMATION

SERIES	LAMP TYPE	COLOUR	VOLTAGE/WATTAGE/LAMP TYPE	OPTION
EF18= single EF18D= double EF18T= triple	Blank= tungsten Q= halogen S= sealed beam H= quartz sealed beam	Blank= factory white B= black C= chrome M= factory white (metal)	-6V9W= tungsten, 6V - 9W, wedge base -6V__W= tungsten, 6V - 18 or 25W, D.C.B. -12V__W= tungsten, 12V - 9 or 18W, wedge base -12V25W= tungsten, 12V - 25W, D.C.B. -24V__W= tungsten, 24V - 9 or 18W, wedge base -24V25W= tungsten, 24V - 25W, D.C.B. -6V__W= halogen, 6V - 8, 12 or 20W, quartz bi-pin -12V__W= halogen, 12V - 8, 12, 20 or 55W, quartz bi-pin -24V__W= halogen, 24V - 20 or 70W, quartz bi-pin -6V__W= tungsten, 6V - 8, 12, 18 or 25W, sealed beam -12V__W= tungsten, 12V - 12, 18 or 25W, sealed beam -6V__W= halogen, 6V - 8, 12 or 20W, quartz sealed beam -12V__W= halogen, 12V - 8, 12 or 37W, quartz sealed beam -32V__W= tungsten, 32V - 18 or 25W, D.C.B. -120V__W= tungsten, 120V-10 or 15W, D.C.B. -120V35W= halogen, 120V - 35W, D.C.B. -120V50W= quartz, 120V - 50W, D.C.B.*	FP= teflon coated lens

EXAMPLE: EF18Q-12V12W



# Distinction™ Series

## Surface Designer Series

Project/Location: \_\_\_\_\_

Contractor: \_\_\_\_\_

Date: \_\_\_\_\_

Prepared by: \_\_\_\_\_

### FEATURES

- Contemporary, enduring design
- Available in 1, 2 or 3 head configurations
- Highly resistant powder-coated, Die-Cast aluminum construction
- MR16 halogen lamps: 6W, 10W, 12W, 20W, 35W and 50W  
MR16 LED lamps: 4W and 5W
- CSA certified to C22.2 No. 141



### DIMENSIONS

Dimensions are approximate and subject to change.

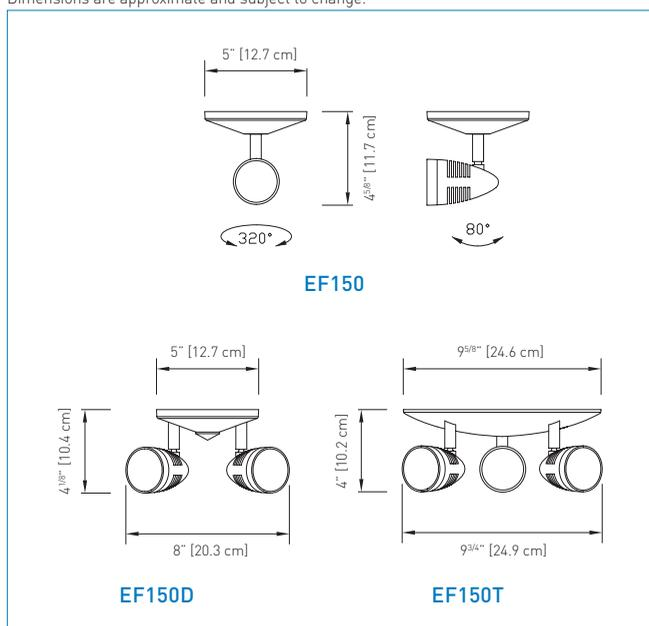

### TYPICAL SPECIFICATIONS

The contractor will supply and install **Emergi-Lite® Distinction Series** remote heads. These remote heads will consist of either single, double or triple head configurations according to the design. Remote heads will be constructed of durable powder coated, Die-Cast aluminum and use MR16 halogen light sources. The remote fixtures shall be certified to CSA C22.2 No.250. The unit shall be **Emergi-Lite®** model: \_\_\_\_\_.

### WIRE GUARDS

460.0029-E	Wall Mount (EF150)
460.0032-E	Wall Mount (EF150D)
460.0078-E	Wall Mount (EF150T)

### REPLACEMENT LAMPS

MODEL	LAMP TYPE	VOLTAGE-WATTAGE
580.0074-E	MR16 flood	6V-6W
580.0080-E	MR16 flood	12V-12W
580.0077-E	MR16 flood	24V-20W
580.0097-E	MR16 LED	6V-4W
580.0093-E	MR16 LED	12V-4W
580.0104-E	MR16 LED	12V-5W
580.0098-E	MR16 LED	24V-4W
580.0095-E	MR16 LED	120V-4W
580.0106-E	MR16 LED	12V-6W

For the complete list, please see the lamp chart on pages 156 to 158

### ORDERING INFORMATION

SERIES	# OF HEADS	COLOUR	VOLTAGE/WATTAGE
EF150= closed	Blank= one head D= two heads T= three heads	Blank= white -B= black	-6V6W= MR16, 6V-6W -6V10W= MR16, 6V-10W -12V12W= MR16, 12V-12W -12V20W= MR16, 12V-20W -12V35W= MR16, 12V-35W -12V50W= MR16, 12V-50W -24V12W= MR16, 24V-12W -24V20W= MR16, 24V-20W -24V35W= MR16, 24V-35W -24V50W= MR16, 24V-50W -LAC= MR16 LED, 6V-4W -LGC= MR16 LED, 12V-4W -LIC= MR16 LED, 12V-5W -LLC= MR16 LED, 24V-4W -LJC= MR16 LED, 12V-6W -LVC= MR16 LED, 120V-4W -20H= MR16 IR, 12V-20W -35H= MR16 IR, 12V-35W -50H= MR16 IR, 12V-50W

EXAMPLE: EF150MD

Project/Location:

Contractor:

Date:

Prepared by:

# EFR Distinction™ Series

Recessed Designer Series



## FEATURES

- Contemporary, enduring designs
- 4W, 5W, 6W, 10W, 12W, 20W, 35W and 50W lamps
- Wide beam MR16 (flood) or LED light source
- Will blend in with regular decorative recessed fixtures
- Choice of housing for new construction or insulated ceiling
- **EFR8NB** and **EFR8R** are made of powder coated or electro-plate steel
- **EFR9** and **EFR2** are made of Die-Cast aluminum



**EFR8NB**



**EFR9**



**EFR8R**



**EFR2**

## BACK BOXES

EL-GRHR03	Non-Insulated ceiling 6-24V	New construction
EL-GRHR04	Non-Insulated ceiling 6-24V	Renovation
EL-GRHR05	Non-Insulated ceiling 120V GU10	New construction
EL-GRHR06	Insulated ceiling 6-24V	New construction

## DIMENSIONS

Dimensions are approximate and subject to change.

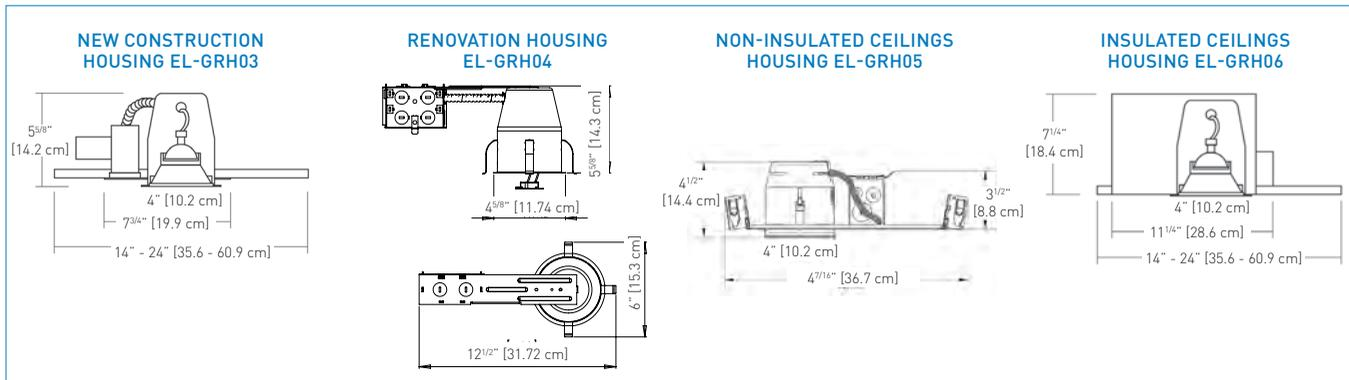

## ORDERING INFORMATION

SERIES	HEAD STYLE	COLOUR	LAMP TYPE	VOLTAGE/WATTAGE
<b>EFR</b> = decorative recessed remote	<b>8NB</b> = flat <b>8R</b> = concave <b>9</b> = concave <b>2</b> = pop-out	<b>WH</b> = white <b>BK</b> = black (18R, 19 & 24 series only) <b>BN</b> = brushed nickel (8R, 8NB & 2 series only) <b>CH</b> = chrome (2 series only) <b>PB</b> = polished brass (2 series only)	<b>MR16</b> = MR16 lamp	<b>-6V6W</b> = MR16, 6V-6W <b>-6V10W</b> = MR16, 6V-10W <b>-12V12W</b> = MR16, 12V-12W <b>-12V20W</b> = MR16, 12V-20W <b>-12V35W</b> = MR16, 12V-35W <b>-12V50W</b> = MR16, 12V-50W <b>-24V12W</b> = MR16, 24V-12W <b>-24V20W</b> = MR16, 24V-20W <b>-24V35W</b> = MR16, 24V-35W <b>-24V50W</b> = MR16, 24V-50W
				<b>-LIC</b> = MR16 LED, 12V-5W <b>-LJC</b> = MR16 LED, 12V-6W <b>-120V20W</b> = GU10, 120V-20W* <b>-120V35W</b> = GU10, 120V-35W* <b>-120V50W</b> = GU10, 120V-50W*

EXAMPLE: EFR8NB-12V20W

## TYPICAL SPECIFICATIONS

The contractor will supply and install **Emergi-Lite® Distinction™ Collection** recessed heads and housing. Recessed heads will be constructed of durable powder coated metal and use MR16 halogen lamps.

The light source will be \_\_\_\_\_ V, \_\_\_\_\_ W MR16 halogen wide beam (flood) or otherwise specified.

The remote unit shall be **Emergi-Lite®** model: \_\_\_\_\_,

and the housing shall be **Emergi-Lite®** model: \_\_\_\_\_.

## REPLACEMENT LAMPS

MODEL	LAMP TYPE	VOLTAGE/WATTAGE
580.0079-E	MR16	6V-10W
580.0080-E	MR16	12V-12W
580.0077-E	MR16	24V-20W
580.0104-E	MR16 LED	12V-5W
580.0106-E	MR16 LED	12V-6W

For the complete list, please see the lamp chart on pages 156 to 158





# Survive-All™ EF39 & EF39P Series

NEMA-4X Certified Remote Fixture

Project/Location: \_\_\_\_\_

Contractor: \_\_\_\_\_

Date: \_\_\_\_\_

Prepared by: \_\_\_\_\_

## FEATURES

- Fully gasketed with a selection of cast aluminum or polycarbonate back plate
- Clear polycarbonate UV and impact resistant lens
- Choice of single or double lamp models
- Available in 6, 12 and 24V models MR16 or LED
- Easy lamp replacement
- Comes standard with tamper-proof screws and bit
- NSF Certified for food processing plants
- NEMA-4X Certified\*
- CSA Certified to C22.2 No. 141
- Suitable for indoor/outdoor installation

\*NEMA-4X Certified when installed using a circular NEMA-4X rated junction box (sold separately by Thomas&Betts under P/N CE365D-CAR or CE365DW-CAR and with plugs P/N P7701W-CAR).



## TYPICAL SPECIFICATIONS

Supply and install **Emergi-Lite® EF39P Series** remote emergency lighting fixtures. These remote fixtures will consist of either single or double lamp configurations according to the design. These fixtures shall be fully gasketed with a UV resistant and fire retardant polycarbonate back plate with a clear heavy-duty UV resistant polycarbonate lens. The unit shall be equipped with two emergency heads with tool-less adjustable swivels (lamps of 12W or less). Units shall be NEMA-4X and NSF certified and specifically designed for high abuse areas, wet and cold weather locations, food processing plants, as well in applications requiring a resistance to corrosive agents. The standard unit will come with stainless steel tamper-proof screws and bit.

The remote fixture shall be certified to CSA C22.2 No. 141. The head(s) shall be fully adjustable without tools and should be equipped with MR16 halogen lamp(s) of \_\_\_\_\_ V \_\_\_\_\_ W.

The remote unit shall be the **Emergi-Lite®** model: \_\_\_\_\_ .

## REPLACEMENT LAMPS: MR16 EF39P

ORDERING CODE	LAMP TYPE	VOLTAGE
580.0074-E	MR16 flood	6V-6W
580.0079-E	MR16 flood	6V-10W
580.0080-E	MR16 flood	12V-12W
580.0070-E	MR16 flood	24V-12W
580.0097-E	MR16 LED	6V-4W
580.0093-E	MR16 LED	12V-4W
580.0104-E	MR16 LED	12V-5W
580.0106-E	MR16 LED	12V-6W
580.0098-E	MR16 LED	24V-4W

For the complete list, please see the lamp chart on pages 156 to 158

## EF39

ORDERING CODE	LAMP TYPE	VOLTAGE
580.0068-E	MR16 infrared	12V-20W
580.0077-E	MR16 flood	24V-20W

Project/Location: \_\_\_\_\_

Contractor: \_\_\_\_\_

Date: \_\_\_\_\_

Prepared by: \_\_\_\_\_

# Survive-All™ EF39 & EF39P Series

NEMA-4X Certified Remote Fixture



## DIMENSIONS

Dimensions are approximate and subject to change.

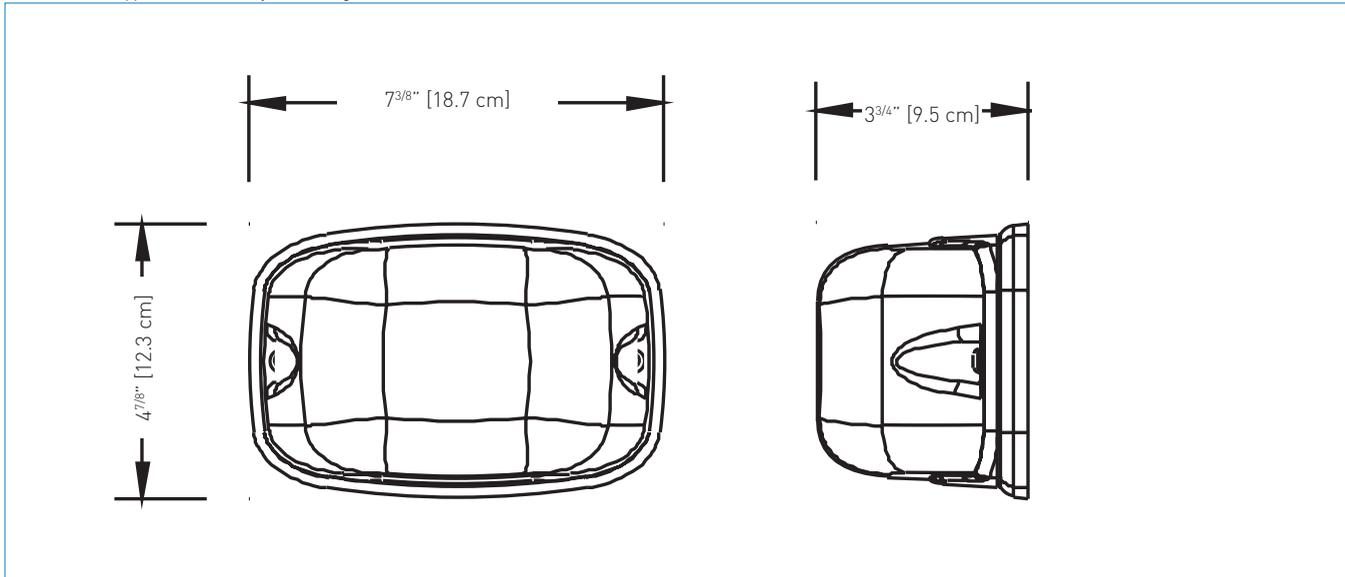

## ORDERING INFORMATION: EF39P

SERIES	NUMBER OF LAMPS	LAMP TYPE	COLOUR	LAMP TYPE/VOLTAGE/WATTAGE
EF39P= polycarbonate NEMA 4X	Blank= one lamp D= two lamps	M= MR16	Blank= factory white -B= black -G= grey	-6V6W= MR16, 6V-6W -6V10W= MR16, 6V-10W -12V12W= MR16, 12V-12W -24V12W= MR16, 24V -12W -LA= MR16 LED 6V-4W -LG= MR16 LED 12V-4W -LI= MR16 LED 12V-5W -LJ= MR16 LED 12V-6W -LL= MR16 LED 24V-4W

EXAMPLE: EF39PDM-B-6V6W

## ORDERING INFORMATION: EF39

SERIES	NUMBER OF LAMPS	LAMP TYPE	COLOUR	LAMP TYPE/VOLTAGE/WATTAGE
EF39= Die-Cast backplate NEMA 4X	Blank= one lamp D= two lamps	M= MR16	Blank= factory white -B= Black -G= grey	-12V20W= MR16IR, 12V-20W -24V20W= MR16, 24V-20W

EXAMPLE: EF39DM-12V20W



# EF25 Series

Weatherproof  
Remote Fixture

Project/Location: \_\_\_\_\_

Contractor: \_\_\_\_\_

Date: \_\_\_\_\_

Prepared by: \_\_\_\_\_

## FEATURES

- Quality illumination requires fewer fixtures
- Weatherproof MR16 powder coated cast aluminum light head
- Up to 24V-50W
- Available single or double head
- Preinstalled on a Red Dot® weatherproof junction box:
  - Five Outlets, 4<sup>1/8</sup>" Diameter
  - Copper-free aluminum provides increased corrosion resistance
  - Precision cast and machined surfaces permit safer wire pulling
  - Clean cover edges provide good gasket sealing
  - Precision NPT threads allow trouble-free field installation for rigid, IMC or EMT conduit
  - Deep slotted stainless steel cover screws for faster installation
- For use with 6V, 12V or 24V DC MR16 or 12V-5W LED lamps

## DIMENSIONS

Dimensions are approximate and subject to change.

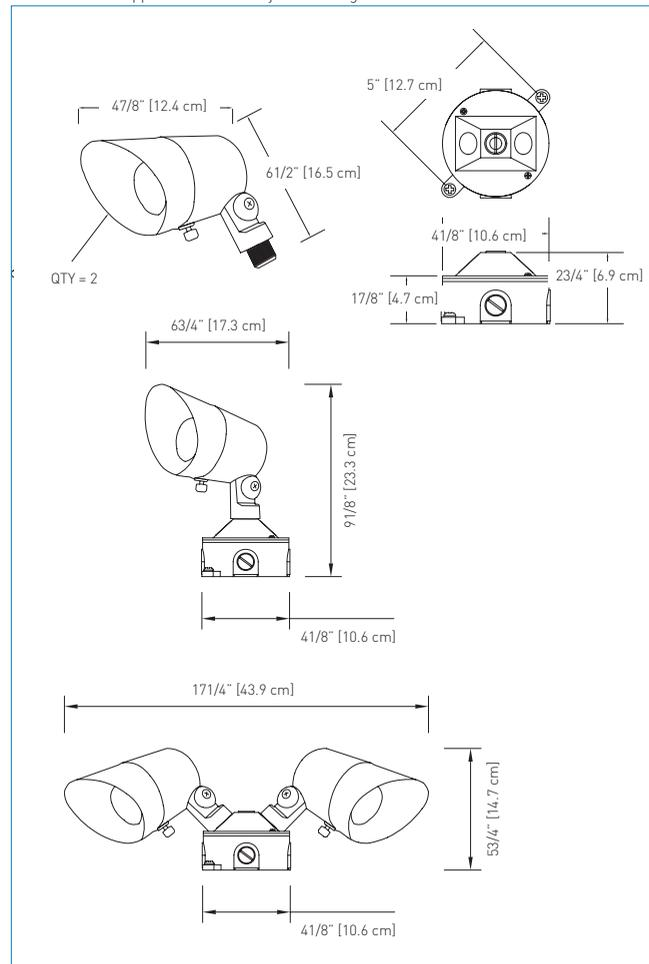

## REPLACEMENT LAMPS

MODEL	LAMP TYPE	VOLTAGE-WATTAGE
580.0079-E	MR16 flood	6V-10W
580.0080-E	MR16 flood	12V-12W
580.0070-E	MR16 flood	24V-12W
580.0104-E	MR16 LED	12V-5W

For the complete list, please see the lamp chart on pages 156 to 158

## ORDERING INFORMATION

SERIES	# OF HEADS	COLOUR	LAMP VOLTAGE	WATTAGE
EF25= weatherproof remotes	Blank= single head D= double head	Blank= standard color black head/grey junction box	-6V= 6VDC -12V= 12VDC -24V= 24VDC	<b>6W</b> = MR16, 6W (6V only) <b>10W</b> = MR16, 10W (6V only) <b>12W</b> = MR16, 12W (12&24V) <b>20W</b> = MR16, 20W (12&24V) <b>35W</b> = MR16, 35W (12&24V) <b>50W</b> = MR16, 50W (12&24V) <b>20WH</b> = MR16, IR, 20W* (12V only) <b>35WH</b> = MR16, IR, 35W* (12V only) <b>50WH</b> = MR16, IR, 50W* (12V only) <b>LI</b> = MR16 LED, 5W (12V only)

\*IR= high output lamp

EXAMPLE: EF25-6V10W

Project/Location:

Contractor:

Date:

Prepared by:

# EF26/EF26DS/ EF26D Series

## Surface Mount Remote Fixture



### FEATURES

- Cubic, vandal-resistant surface-mounted fixture
- Single, double or twin cube with center body
- Frosted polycarbonate cube
- CSA certified to C22.2 No. 141



### DIMENSIONS

Dimensions are approximate and subject to change.

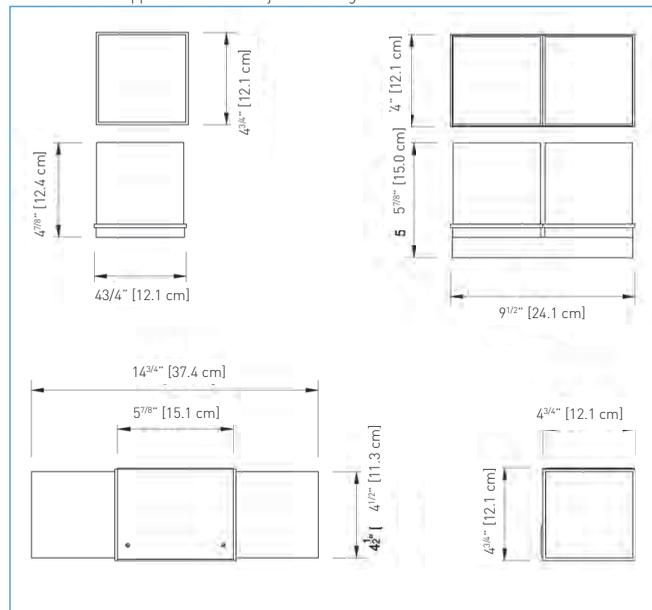

### TYPICAL SPECIFICATIONS

Remote heads **EF26/EF26DS/EF26D Series** shall be comprised of one (single) or two (double or twin) 12W adjustable heads with halogen lamps. Each lamp shall be housed in an impact-resistant polycarbonate cube. The cube lens shall be frosted to diffuse the light.

Heads shall provide mounting holes for installation on a standard octagonal box.

The remote unit shall be the **Emergi-Lite®** model: \_\_\_\_\_.

### WIRE GUARDS

460.0035-E	Wall Mount (EF26)
460.0032-E	Wall Mount (EF26D)
460.0031-E	Wall Mount (EF26DS)

### REPLACEMENT LAMPS

MODEL	LAMP TYPE	VOLTAGE/WATTAGE
570.0016-E	Mini tungsten, wedge base	6V-9W
460.00311-E	Mini halogen (quartz), bi-pin	6V-12W
580.0079-E	MR16, flood	6V-10W

For the complete list, please see the lamp chart on pages 156 to 158

### IN THE SAME FAMILY



### DEL SERIES

P. 106-107

### ORDERING INFORMATION

SERIES	LAMP STYLE	COLOUR	LAMP STYLE/WATTAGE	OPTIONS	
EF26= single cube EF26D= double cube EF26DS= twin cube	Blank= tungsten Q= halogen M= MR16	Blank= factory white B= black	-6V9W= 6V-9W, wedge base -12V9W= 12V-9W, wedge base -12V18W= 12V-18W, wedge base -24V9W= 24V-9W, wedge base -6V8W= 6V-8W, quartz bi-pin -6V12W= 6V-12W, quartz bi-pin -12V8W= 12V-8W, quartz bi-pin -12V12W= 12V-12W, quartz bi-pin -12V20W= 12V-20W, quartz bi-pin -24V20W= 24V-20W, quartz bi-pin -6V6W= MR16, 6V-6W -6V10W= MR16, 6V-10W -12V12W= MR16, 12V-12W -12V20W= MR16, 12V-20W -12V35W= MR16, 12V-35W -12V50W= MR16, 12V-50W -24V20W= MR16, 24V-20W -24V35W= MR16, 24V-35W -24V50W= MR16, 24V-50W -LA= MR16 LED, 6V-4W -LG= MR16 LED, 12V-4W -LI= MR16 LED, 12V-5W -LL= MR16 LED, 24V-4W	-LJ= MR16 LED, 12V-6W -24V18W= 24V-18W, wedge base -120V20W= GU10 120V-20W -120V35W= GU10 120V-35W	Blank= no options TP= tamper-proof screws 690.0454-E= tamper-proof bit*

\*One bit per order

EXAMPLE: RSQBTV9W.....



# EF11 Series

## Remote Fixture

Project/Location:	_____
Contractor:	_____
Date:	_____
Prepared by:	_____

### FEATURES

- Available in single, double or triple head fixtures
- Durable thermoplastic construction suitable for industrial or high abuse areas
- Tool-less adjustment and aiming of lamp heads
- Certified CSA C22.2 No.141
- Weatherproof



### WIRE GUARDS

460.0035-E	Wall Mount (EF11)
460.0082-E	Wall Mount (EF11D)

### REPLACEMENT LAMPS

MODEL	LAMP TYPE	VOLTAGE-WATTAGE
570.0016-E	Tungsten	6V-9W
570.0025-E	Tungsten	12V-9W
570.0079-E	Tungsten	24V-9W

For the complete list, please see the lamp chart on pages 156 to 158

### DIMENSIONS

Dimensions are approximate and subject to change.

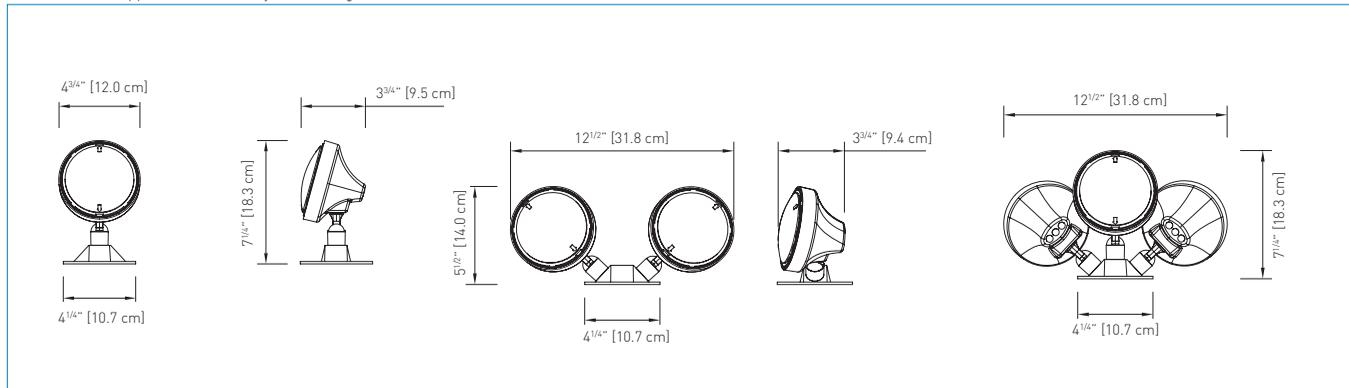

### ORDERING INFORMATION

SERIES	LAMP STYLE	COLOUR	VOLTAGE/WATTAGE	OPTIONS
EF11= single, PAR 36 EF11D= double, PAR 36 EF11T= triple, PAR 36	Blank= tungsten Q= halogen	Blank= black W= factory white	-6V9W= tungsten, 6-9W, wedge base -6V__W= tungsten, 6V-18 or 25W, D.C.B. -12V__W= tungsten, 12V-9 or 18W, wedge base -12V25W= tungsten, 12V-25W, D.C.B. -24V__W= tungsten, 24V-9 or 18W, wedge base -24V25W= tungsten, 24V-25W, D.C.B. -6V__W= halogen, 6V-8, 12 or 20W, quartz bi-pin -12V__W= halogen, 12V-8, 12, 20 or 55W, quartz bi-pin -24V__W= halogen, 24V-20 or 70 W, quartz bi-pin -6V__W= tungsten, 6V-8, 12, 18 or 25W, sealed beam -12V__W= tungsten, 12V-12, 18 or 25W, sealed beam -6V__W= halogen, 6V-8, 12 or 20W, quartz sealed beam -12V__W= halogen, 12V-8, 12 or 37W, quartz sealed beam -32V__W= tungsten, 32V-18 or 25W, D.C.B. -120V__W= tungsten, 120V-10, 15 or 30W, D.C.B. -120V__W= halogen, 120V-35 or 50W, D.C.B.	FP= teflon coated lens
			*NOTE: " __ " = insert wattage required	

EXAMPLE: EF11Q-12V12W

Project/Location:

Contractor:

Date:

Prepared by:

# EF30 Series

## Remote Fixture



### FEATURES

- Sealed beam, surface-mounted, rubber coated industrial remote fixture
- For use in high pressure hose down areas
- Available only in black
- Certified CSA C22.2 No.141

### REPLACEMENT LAMPS

MODEL	LAMP TYPE	VOLTAGE-WATTAGE
550.0026-E	Tungsten	12V-12W
550.0027-E	Tungsten	12V-18W
550.0023-E	Tungsten	12V-25W

\*Lamps for RS10QWPBH.  
For the complete list, please see the lamp chart on pages 156 to 158



### DIMENSIONS

Dimensions are approximate and subject to change.

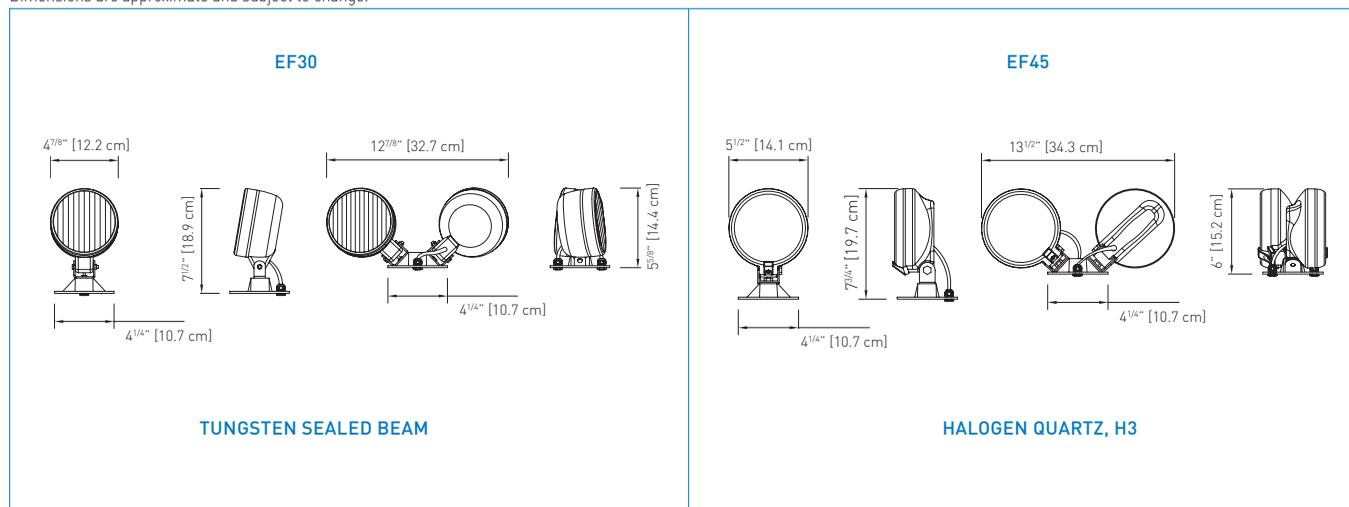

TUNGSTEN SEALED BEAM

HALOGEN QUARTZ, H3

### ORDERING INFORMATION

SERIES	LAMP STYLE	VOLTAGE	OPTIONS
EF30= single PAR 36 EF30D= double, PAR 36	S= sealed beam H= quartz sealed beam	-6V__W= tungsten, 6V - 8, 12, 18 or 25W, sealed beam -12V__W= tungsten, 12V - 12, 18 or 25W, sealed beam -6V__W= halogen, 6V - 8, 12 or 20W, quartz sealed beam -12V__W= halogen, 12V - 8, 12 or 37W, quartz sealed beam	FP= teflon coated lens

\*NOTE: "\_\_" = insert wattage required.

EXAMPLE: EF30S-6V9W

### ORDERING INFORMATION

SERIES	LAMP STYLE	VOLTAGE	OPTIONS
EF45Q= single EF45DQ= double	S= sealed beam H= quartz sealed beam	-12V55W= halogen, 12V - 55W, H3 -24V70W= halogen, 24V - 70W, H3	FP= teflon coated lens

\*NOTE: "\_\_" = insert wattage required.

EXAMPLE: EF45QS-12V55W



# EF41 Series

## Hazardous Location

Project/Location: \_\_\_\_\_

Contractor: \_\_\_\_\_

Date: \_\_\_\_\_

Prepared by: \_\_\_\_\_

### FEATURES

- Quality illumination requires fewer fixtures
- Certified Class I Zone 2, Groups IIA, IIB and IIC
- Certified Class I Division 2, Groups A, B, C and D as per CSA C22.2 No.137-M1981
- Temperature Codes: T3B (10W and 12W MR16 lamps) and T2C (20W MR16 lamps), as per Canadian Electrical Code, Part I and CSA C22.2 No.137-M1981
- Extreme operational temperature range: -40°C to +40°C.
- Choice of single- or double-lamp models
- High-efficacy MR16 halogen lamps of 10W, 12W and 20W (see specification table)
- Input voltage: 6V, 12V, 24V or 120V
- Fully gasketed Die-Cast aluminum back plate
- Clear polycarbonate cover, UV and impact resistant
- Easy installation on a 4" octagonal box (included)
- Comes standard with tamper-proof screws and bit
- Meets or exceeds CSA 22.2 No.141



### DIMENSIONS

Dimensions are approximate and subject to change.

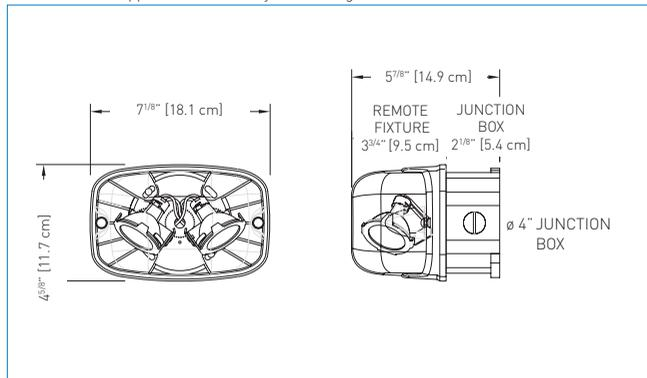

### TYPICAL SPECIFICATIONS

Supply and install **Emergi-Lite® EF41 Series** remote emergency lighting fixture. The fixture shall have a single- or double-lamp configuration (as specified) and shall include a fully gasketed Die-Cast aluminum back plate and a clear heavy-duty UV resistant polycarbonate cover. The fixture shall come standard with a 4" octagonal box, stainless steel tamper-proof screws and dedicated screwdriver bit.

The fixture shall be certified for use in hazardous locations Class I, Division 2, Groups A, B, C and D and shall be listed to CSA C22.2 No. 141 and CSA C22.2 No.137-M1981. The fixture shall be rated with a temperature code for the selected lamps as in the table below.

Each lamp in the fixture shall be able to be oriented without tools and should be equipped with MR16 halogen lamp(s) of \_\_\_\_\_ V \_\_\_\_\_ W.

The remote unit shall be **Emergi-Lite®** model: \_\_\_\_\_ .

### REPLACEMENT LAMPS

MODEL	LAMP TYPE	VOLTAGE/WATTAGE	TEMPERATURE CODE
580.0079-E	MR16 Flood	6V-10W	T3B (Max. 165°C)
580.0068-E	MR16-IR Flood (high output)	12V-20W-H	T2C (Max. 230°C)
580.0077-E	MR16 Flood	24V-20W	T2C (Max. 230°C)
580.0080-E	MR16 Flood	12V-12W	T3B (Max. 165°C)
580.0070-E	MR16 Flood	24V-12W	T3B (Max. 165°C)

For the complete list, please see the lamp chart on pages 156 to 158

### ORDERING INFORMATION

SERIES	NUMBER OF LAMPS	LAMP TYPE	COLOUR	VOLTAGE/WATTAGE/LAMP TYPE
EF41	Blank= one lamp D= two lamps	M= MR16 MH= MR16 high output (12V-20W only)	-G= grey	-6V10W= MR16, 6V-10W -12V12W= MR16, 12V-12W -12V20W= MR16, 12V-20W -24V12W= MR16, 24V-12W -24V20W= MR16, 24V-20W -12/20H= MR16 high output, 12V-20W

EXAMPLE: EF41M-G-6V10W

Project/Location:

Contractor:

Date:

Prepared by:

# EFXPR Series

## Hazardous Location



### FEATURES

- CSA Certified for use in hazardous locations:
  - Class I, Divisions 1 and 2, Groups A, B, C, D
  - Class II, Divisions 1 and 2, Groups E, F, G
  - Class III, Divisions 1 and 2
- Die-Cast aluminum body with grey epoxy powder coat finish
- Clear, impact and heat resistant prismatic glass globe
- Available in 6, 12 and 24V
- Available with single-lamp or twin-lamp combination
- New, easy-to-build catalogue number based on the **Emergi-Lite®** Severity Codes
- Meets or exceeds CSA 22.2 No.141



### TYPICAL SPECIFICATIONS

Supply and install the **Emergi-Lite® EFXPR Series** of hazardous location remote heads. The head housing will be Die-Cast aluminum with grey epoxy powder coat finish. The lens shall be a clear, impact and heat resistant prismatic glass globe. The head shall be factory sealed. External seals shall not be required.

The remote shall come complete with a \_\_\_\_\_ mounting connection and include \_\_\_\_\_ lamp(s) rated \_\_\_\_\_ V \_\_\_\_\_ W.

The remote head shall be suitable for Class \_\_\_\_\_, Division \_\_\_\_\_, Group \_\_\_\_\_.

The remote unit shall be **Emergi-Lite®** model: \_\_\_\_\_.

### REPLACEMENT LAMPS

MODEL	TYPE	VOLTAGE/WATTAGE
580.0011-E	Halogen	6V-12W
580.0015-E		12V-12W
580.0027-E		12V-20W
580.0023-E		24V-20W

### DIMENSIONS

Dimensions are approximate and subject to change.

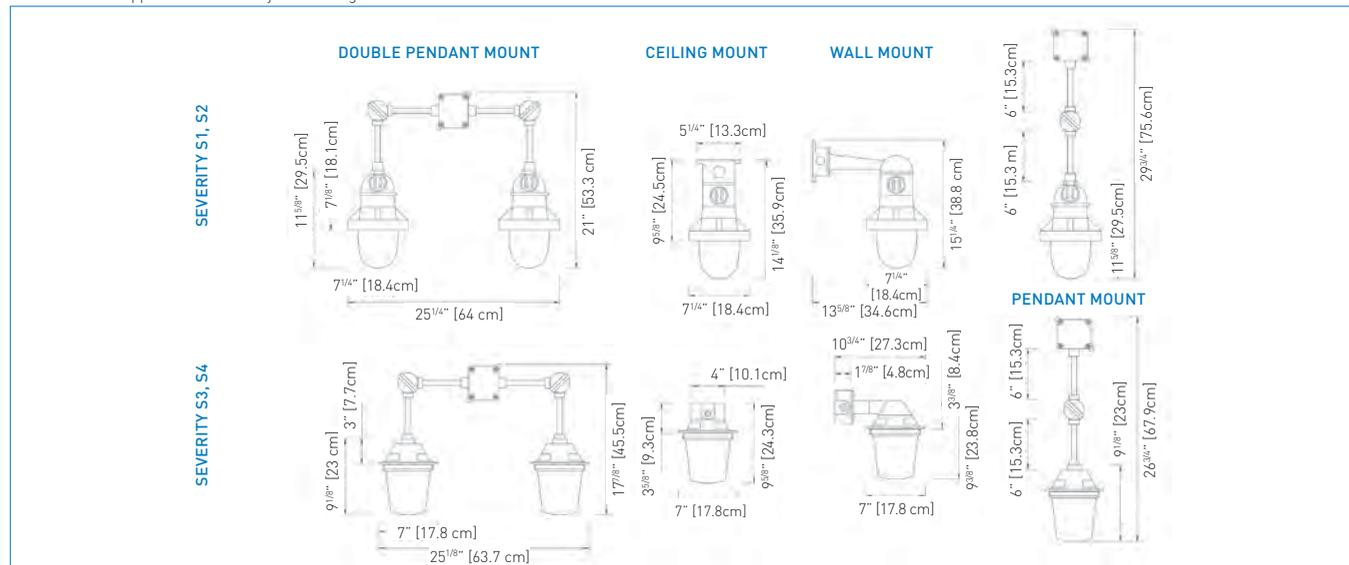

1.

ENVIRONMENT	SEVERITY CODE
Cl. I, Div. 1, Gr. B	S1
Cl. I, Div. 1, Gr. C, D	S2
Cl. I, Div. 2, Gr. B, C, D	S3

2.

CERTIFICATION GUIDE FOR REMOTE LIGHTING FIXTURES (40°C AMBIENT)				
Severity Code	S1	S2	S3	S4
Temperature Code	T4A	T6	T1	T3C (E.G.F.)
CSA/UL rating	Max. 120°C [248°F]	Max. 85°C [185°F]	Max. 450°C [842°F]	Max. 165°C [329°F]

### ORDERING INFORMATION

SERIES	MOUNTING	NUMBER OF LAMPS	SEVERITY CODE	VOLTAGE	LAMP WATTAGE/TYPE
EFXPR	C= ceiling mount P= pendant mount W= wall mount	11= single remote, one lamp 12= single remote, two lamps 21= double remote, one lamp* *Pendant mount only.	S1= CL.1, Div.1, Gr.A, B S2= CL.1, Div.1, Gr.C, D S3= CL.1, Div.2, Gr.A, B, C, D S4= CL.2, Div.1,&2, Gr.E, F, G CL3, Div. 1&2	-6V= 6V -12V= 12V -24V= 24V -120V= 120V	12W= halogen, 6V, 12V-12W, quartz bi-pin 20W= halogen, 12, 24V-20W, quartz bi-pin

EXAMPLE: EFXPRP11S3-6V12W

# Lamp Chart

LAMP TYPE	CODE	VOLTAGE	LUMEN												
				LUXRAY		EF40		LITRAY		RETRACT-A-LITE		EF9 / Q / M		EF18/D/T	
				A	B	A	B	A	B	A	B	A	B	A	B
 MR16 halogen lamps	580.0074-E	6V - 6W	40			7'	1'					8'	3'		
	580.0079-E	6V - 10W (flood)	77			21'	20'	X	X			23'	22'		
	580.0080-E	12V - 12W (flood)	135			25'	17'	16'	-	31'	19'	31'	19'		
	580.0075-E	12V - 20W*	270									54'	41'		
	580.0064-E	12V - 20W (flood)	245			50'	36'	36'	-	53'	39'	53'	39'		
	580.0068-E	12V - 20WH (flood)	417			65'	50'			70'	54'	70'	54'		
	580.0090-E	12V - 35WH (flood)	853							130'	110'	130'	110'		
	580.0089-E	12V - 50WH (flood)	1550							160'	171'	160'	171'		
	580.0083-E	12V - 35W (flood)	490							96'	86'	96'	86'		
	580.0076-E	12V - 50W (flood)	785							126'	100'	126'	100'		
	580.0077-E	24V - 20W (flood)	240			46'	37'	X	X	48'	38'				
	580.0070-E	24V - 12W (flood)	95			22'	13'	X	X	25'	15'	25'	15'		
	580.0084-E	24V - 35W (flood)	460							76'	60'				
	580.0078-E	24V - 50W (flood)	875							139'	12'				
	580.0065-E	120V - 20W (flood)	100			26'	17'								
580.0066-E	120V - 35W (flood)	230													
580.0067-E	120V - 50W (flood)	460													
 MR16, LED lamps	580.0097-E	6V - 4W	130			35'	23'	X	X	X	X	38'	25'		
	580.0093-E	12V - 4W	170			39'	23'	28'	-	41'	25'	41'	25'		
	580.0104-E	12V - 5W	340			71'	56'	71'	56'	71'	56'	71'	56'		
	580.0098-E	24V - 4W	200			41'	52'	X	X	52'	41'	52'	41'		
	580.0095-E	120V - 4W	200												
	580.0106-E	12V - 6W	510			100'	85'	100'	85'	100'	85'	100'	85'		
 par 36, Sealed beam halogen lamps	550.0036-E	6V - 8W	155											X	X
	550.0037-E	6V - 10W	190											X	X
	550.0021-E	6V - 20W	380											68'	55'
	550.0024-E	12V - 8W	130											25'	18'
	550.0025-E	12V - 12W	240											45'	37'
	550.0030-E	6V - 12W	225											X	X
 par 36, Sealed beam lamps	550.0018-E	6V - 8W	130											17'	14'
	550.0016-E	6V - 18W	270											29'	18'
	550.0017-E	6V - 25W	400											75'	48'
	550.0026-E	12V - 12W	190											31'	23'
	550.0027-E	12V - 18W	210											31'	19'
	550.0023-E	12V - 25W	395											68'	43'
 t-3 1/4, Xenon lamps	570.0213-E	6V - 6W	120	17'	-										
	570.0214-E	6V - 10W	180	25'	18'										
	570.0215-E	12V - 6W	105	X	X										
	570.0216-E	12V - 10W	200	X	X										
	570.0211-E	24V - 12W	240											X	X

A= TYPICAL SPACING 7" MOUNTING 6" WIDE  
B= TYPICAL SPACING 15" MOUNTING 6" WIDE

TYPICAL SPACING IS BASED ON A 6" WIDE PATH AND 80.50.20 REFLECTANCES.

EF26/DS/D		DISTINCTION		EFR		EF15		EF11		EF30		EF25		EF39		EF41	
A	B	A	B	A	B	A	B	A	B	A	B	A	B	A	B	A	B
X	X	8'	3'	X	X			X	X			X	X	X	X		
X	X	23'	22'	X	X			X	X			160'	171'	21'	20'	21'	20'
X	X	31'	19'	31'	19'			X	X			31'	19'	25'	17'	25'	17'
								X	X								
		53'	39'	53'	39'							53'	39'	50'	36'	X	X
X	X	70'	54'	70'	54'							70'	54'	65'	50'		
X	X	130'	110'	130'	110'							130'	110'	X	X		
X	X	160'	171'	160'	171'							160'	171'	X	X		
		96'	86'	96'	86'							96'	86'	X	X		
		126'	100'	126'	100'							126'	100'	X	X	X	X
X		48'	38'	X	X							48'	38'	46'	37'	X	X
		25'	15'	X	X			X	X			25'	15'	22'	13'		
X	X	76'	60'	X	X							76'	60'	X	X		
X	X	139'	12'	X	X							139'	112'	X	X		
		28'	19'	X	X									26'	17'	21'	20'
		42'	38'	X	X									X	X		
		65'	58'	X	X									X	X		
X	X	38'	25'	38'	25'									X	X		
X	X	41'	25'	41'	25'									X	X		
71'	56'	71'	56'	71'	56'									71'	56'		
X	X	52'	41'	52'	41'									X	X		
		43'	39'														
100'	85'	100'	85'	100'	85'											100'	85'
								X	X	X	X						
								X	X	X	X						
								68'	55'	68'	55'	68'	55'				
								25'	18'	25'	18'	25'	18'				
								45'	37'	45'	37'	45'	37'				
								X	X	X	X						
								17'	14'	17'	14'	17'	14'				
								29'	18'	29'	18'	29'	18'				
								75'	48'	75'	48'	75'	48'				
								31'	23'	31'	23'	31'	23'				
								X	X	X	X						
								68'	43'	68'	43'	68'	43'				

Consult your sales representative

A= TYPICAL SPACING 7" MOUNTING 6" WIDE  
 B= TYPICAL SPACING 15" MOUNTING 6" WIDE

TYPICAL SPACING IS BASED ON A 6" WIDE PATH AND 80.50.20 REFLECTANCES.

# Lamp Chart

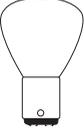
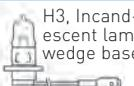
LAMP TYPE	CODE	VOLTAGE	LUMEN	PROVIDER®		EF9 / Q / M		EF18/D/T		EF26/ DS/D		EF15		EF11		EF30		EFXPR	
				A	B	A	B	A	B	A	B	A	B	A	B	A	B	A	B
					570.0040-E	24V - 18W	250					X	X			X	X	X	X
S8, High intensity tungsten lamps double contact bayonet base	570.0037-E	6V - 18W	300					10'	-			10'	-	10'	-				
	570.0031-E	12V - 25W	400					X	X			X	X	X	X				
	570.0061-E	24V - 25W	400					X	X			X	X	X	X				
	570.0120-E	120V - 15W	94					X	X	x	x	16'	5'	X	X				
	570.0025-E	12V - 9W	138					X	X			X		X	X				
	570.0020-E	6V - 13W	188																
	570.0011-E	12V - 9W	126																
	570.0038-E	6V - 25W	400					X	X			X	X	X	X				
	570.0022-E	12V - 13W	188					X	X			X	X	X	X				
	570.0030-E	12V - 18W	276					X	X			X	X	X	X				
	570.0058-E	24V - 9W	75					X	X			X	X	X	X				
	580.0012-E	6V - 6W	113			X	X	X	X			X	X	X	X				
	580.0017-E	6V - 10W	200			X	X	X	X			X	X	X	X				
	580.0013-E	6V - 8W	163			23'	14'	17'	14'	17'	14'	17'	14'	17'	14'				
	580.0011-E	6V - 12W	240			23'	16'	15'	12'	15'	12'	15'	12'	15'	12'			X	X
	580.0022-E	6V - 20W	400					23'	17'			23'	17'	23'	17'			X	X
	580.0014-E	12V - 8W	163			24'	17'	16'	13'	16'	13'	16'	13'	16'	13'				
	580.0015-E	12V - 12W	276			X	X	20'	15'	20'	15'	20'	15'	20'	15'			X	X
	580.0023-E	24V - 20W	133					21'	15'	21'	15'	21'	15'	21'	15'			X	X
	580.0016-E	12V - 14W	300					X	X			X	X	X	X				
	580.0027-E	12V - 20W	314					34'	26'	34'	26'	34'	26'	34'	26'			X	X
	580.0030-E	12V - 55W	748					108'	78'					X		104'	74'		
	580.0031-E	24V - 70W	791					104'	74'					X		108'	74'		
	570.0026-E	6V - 7.2W	100	X	X			X	X	X	X	X	X	X	X				
	570.0016-E	6V - 9W	150	X	X	12'	5'	12'	-	12'	-	12'	-	12'	-				
	570.0025-E	12V - 9W	138	X	X	14'	8'	18'	13'	18'	13'	18'	13'	18'	13'				
	570.0028-E	12V - 12W	150					x	x			X	X	X	X				
	570.0029-E	12V - 18W	264			24'	14'	18'	12'	18'	12'	18'	12'	18'	12'				
	570.0045-E	24V - 9W	113	X	X	12'	2'	15	9'	15'	9'	15'	9'	15'	9'				
	570.0046-E	24V - 18W	240			21'	10'	21'	15'	21'	15'	21'	15'	21'	15'				
	570.0012-E	6V - 5.4W	68	X	X			X	X			X	X	X	X				

A= TYPICAL SPACING 7" MOUNTING 6" WIDE  
 B= TYPICAL SPACING 15" MOUNTING 6" WIDE

TYPICAL SPACING IS BASED ON A 6" WIDE PATH AND 80.50.20 REFLECTANCES.

# Glossary

<b>FP</b>	Food Processing	A protective teflon coating that is applied to the glass lens of a lighting fixture to prevent broken shards from falling if the glass is accidentally broken or vandalised.
<b>TP</b>	Tamper-proof screws*	Screws that require a special bit. Can be used on certain units to deny access to unauthorized personnel.

\*Only applicable to remotes



CENTRAL  
SYSTEMS

UNITY  
SERIES

CH  
SERIES

AC INVERTERS



# CENTRAL SYSTEMS

# TABLE OF CONTENTS

							
<b>WHAT IS EMEX?</b>	<b>IPS SINGLE PHASE SERIES</b>	<b>IPS THREE PHASE SERIES</b>	<b>SYSTEM OPTIONS</b>	<b>USER INTERFACE &amp; DISPLAY FUNCTIONS</b>	<b>CENTRAL SYSTEM REQUEST DATA FORM</b>	<b>UNITY SERIES</b>	<b>CH SERIES</b>
P. 164-165	P. 166-167	P. 168-169	P. 170	P. 171	P. 172	P. 174-175	P. 176-178

# What is Emex?

A General Presentation about Emex Central Systems

Project/Location:

Contractor:

Date:

Prepared by:

## CHOOSING THE RIGHT SYSTEM

**There are a variety of ways in which back-up power can be provided. However, even though certain methods are suitable for critical applications, they may not necessarily be suitable for Emergency Lighting.**

This is because an Emergency Lighting system has unique load characteristics. And since Emergency Lighting is a critical life-safety installation, it is vital that a Central Battery System is designed with these load characteristics in mind. EMEX Power central inverter systems are specifically designed to provide emergency power for emergency lighting systems in a power failure.



**In choosing the right AC system to support emergency lighting it is important to consider the following questions:**

### Overload performance

Is the system able to start the full load without the mains supply present. How does the system perform in a total power failure (ie is the system able to start the load without the bypass supply being available)?

### Repeat duty

CSA141-10 requires a central battery system to fully recharge within 24 hours. Is the charger able to recharge the batteries quickly (80% in 14 hours or 100% after 24 hours)?

### Energy consumption and heat dissipation

Are the inverter and charger permanently running, shortening the battery life, generating heat, wasting energy and shortening component life? Are cooling fans running continuously, generating noise?

### Maintenance

Is the system easy to service and maintain? Is the system designed in a modular format, or would the failure of even a minor component require the whole system to be shut down and stripped for repair?.

## General information on UPS systems:

### Recharge period

UPS systems which are designed primarily for computer back-up generally offer short run times, 5 or 10 minutes. The long run times required for emergency lighting call for more powerful chargers to recharge the larger bank of batteries needed in the time prescribed by CSA.

### Overload performance

An emergency lighting load will impose large "in-rush" currents when starting lamps from cold. However, UPS systems are often designed to shut down at only 125% overload and revert to the incoming supply. During a total power failure situation, this could result in total failure of the emergency lighting system. Furthermore, a UPS may fail to clear a breaker on a lighting circuit, meaning that a single short circuit fault could result in loss of the entire emergency lighting supply.

### Energy consumption and battery life

Most UPS systems operate in the "on-line" mode, whereby the inverter runs constantly to supply the load, and power is taken from the battery with the charger running constantly. This places an excessive ripple on the battery (contrary to the advice given by most battery manufacturers). Also, the system is constantly generating heat which has a further detrimental effect on battery life. There are energy costs and heat generation issues must be addressed when running an on-line system.

Project/Location:

Contractor:

Date:

Prepared by:

# What is Emex?

## A General Presentation about Emex Central Systems

### SYSTEM DESIGN

The EMEX Power inverter and charger modules utilize solid state electronics of the highest reliability to provide a rugged, easy to maintain system with exceptional performance for emergency lighting use. The system has been designed solely for emergency lighting, and not modified from other less essential power supply requirements. As such, the system has exceptional overload performance without the need to over-specify the rating of the inverter to ensure faults can be cleared.

Each module has input and output protection and each module measures and limits its own current.

Alarms and status indications are provided on the front panel display, which provide clear and concise information, rather than a long list of parameters, which may be confusing.

### SERIES HIGHLIGHTS

#### Performance

The EMEX-Power Systems work with lighting loads to provide full light output for minimum 30 min. It is designed to support incandescent, fluorescent and LED loads. It will power these loads at cold starts for all normally off circuits or normally on circuits.

#### True Sine Waveform

Using a solid-state, pulse width modulation (PWM) inverter, the systems produce pure sinusoidal output waveform with less than 5% Total Harmonic Distortion (THD) for linear loads.

#### Reliability

The product is third generation inverter technology. LVD (Low Voltage Disconnect) circuitry eliminates excessive battery drain after long power outages.

#### Batteries

Automatic restart and recharge upon restoration of utility.

#### Approvals

- CSA C22.2 No. 141-10 – Emergency Lighting Equipment
- CSA C22.2 No. 107.3 – Uninterruptible Power Systems
- UL 1778 – Uninterruptible Power Systems

#### Applications

EMEX-Power Systems can be used in almost every type of building, especially in architecturally sensitive applications or when maintenance costs and testing of individual unit equipment becomes significant. Our systems are designed to work with power factor corrected as well as the most recent T5 and T5-HO electronic ballasts.

## FEATURES

#### SELF-DIAGNOSTIC/SELF-TESTING

Programmable monthly and annual self-testing. Proven self-diagnostic with information stored in separate memory logs for Test, Event and Alarm. Microprocessor monitoring and control.

#### LOW HEAT DISSIPATION

Very low heat loss in standby operating mode (see specifications for exact values). Convection cooling in normal mode with forced air during emergency and recharge mode. Battery cabinets: convection cooling only.

#### VERSATILE INSTALLATION

Modular design, easy front access freestanding cabinets, fasten together when more than one cabinet is required. Optional seismic kit available. All wiring provided is pre-cut and terminated, along with the necessary hardware for proper installation.

#### COMPLETE PROTECTION

Battery circuit breakers are standard. Modular standard systems offer overload capacity, short-circuit protection, current-limiting, low-battery disconnect and brownout protection as standard.

#### THERMAL PERFORMANCE

Bonded oversized heat sinks for maximum thermal performance. Cooling fans are energized only in inverter and recharge modes.

#### MONITORING AND CONTROL

User friendly programmable interface with LCD display provides full metering values, easy program and control functions and a wide range of visual and audible alarms.

## BENEFITS

#### COMPLIANCE WITH NFPA101

The self-testing meets the requirements of NFPA and UL. User programmable time of testing. Test results, events or alarms can be downloaded from history logs. Load monitoring. Reduced testing/service time.

#### LESS AIR-CONDITIONING

Reduced costs for air-conditioning required to ensure the optimum operating temperature when compared with equivalent systems that dissipate much more heat. Higher reliability of fans and electronic components.

#### EASY TO INSTALL

Quick installation and connection through flexible cable entries and fast access terminal blocks. Low MTTR (<30 min.) due to modular design, quick disconnect means and frontal access.

#### REDUCED DAMAGE RISKS

The full protection of the system will eliminate damage created by external events and will increase lifetime of the electronics and the batteries.

#### INCREASED MTBF

Increased reliability and reduced preventative maintenance. No air filters needed.

#### EASY MAINTENANCE

Diagnostics, troubleshooting, preventative maintenance and service are made easier by using the front panel display or the history logs.

# IPS SINGLE PHASE SERIES

Interruptible emergency lighting inverter system 3KVA – 15KVA

Project/Location: \_\_\_\_\_

Contractor: \_\_\_\_\_

Date: \_\_\_\_\_

Prepared by: \_\_\_\_\_



## FEATURES

- PWM/Power Mosfet technology
- Self-testing/Self-diagnostic
- User programmable with password protection
- User programmable variable time delay
- Optional 100% normally Off output
- RS485 MODBUS RTU communication port
- Micro-processor controlled
- 30, 60, 90, 120 minutes run times
- Summary alarm form C dry contact
- Generator compatibility
- Electronic and magnetic ballast compatible
- Automatic event, test and alarm log
- LCD display
- Maintenance free standard batteries
- Forced air cooling during emergency and recharge mode only
- Off when on standby

## ELECTRICAL/MECHANICAL CHARACTERISTICS FOR 30 MINUTES BACK-UP TIME

POWER RATING KVA/KW	EFFIC. AT FULL LOAD %	MAX. INPUT CURRENT (A) <sup>(1)</sup>				HEAT LOSS IN NORMAL MODE (BTU/HR)	BATT. VDC	BATT. ADC	NO. OF BATT. <sup>(1)</sup>	IPS CABINET DIMENSIONS			NO. OF BATT. CAB. <sup>(1)(2)</sup>	BATT. CABINET DIMENSIONS			IPS CABINET WEIGHT KG <sup>(1)</sup>	BATT. CABINET WEIGHT KG (EMPTY) <sup>(1)</sup>	BATTERY WEIGHT KG <sup>(1)</sup>	TOTAL SYSTEM WEIGHT KG <sup>(1)</sup>
		120V	240V	277V	347V					W"	H"	D"		W"	H"	D"				
3.0	98%	42	21	18	14	546	120	34	10	30	71	27	NA	NA	NA	NA	240	NA	105	345
6.0	98%	67	33	29	23	546	120	68	20	30	71	27	NA	NA	NA	NA	290	NA	210	500
9.0	98%	92	46	40	32	546	120	101	10	30	71	27	NA	NA	NA	NA	340	NA	372	712
12.0	98%	117	58	51	40	546	120	135	20	30	77	27	1	30	77	27	390	140	550	1080
15.0	98%	142	71	61	49	546	120	168	20	30	77	27	1	30	77	27	440	140	550	1130

1- For 30 min. discharge time. For other discharge times, consult factory.

2- Batteries are installed in the IPS cabinet for 3 to 9.0KVA systems, for 30 minutes only.

## ORDERING INFORMATION<sup>(1)</sup>

SERIES	SYSTEM VOLTAGE	KVA/KW	RUN TIME	EXTERNAL CIRCUIT BREAKER	OPTIONS
E= Series	1= 120-120 input-output 2= 120/240-120/240 [3 wire in-out] 3= 277-277 4= 347-347	A= 3 B= 6 C= 9 D= 12 E= 15*	3= 30 minutes 6= 60 minutes 9= 90 minutes 12= 120 minutes	B= no breakers N####= normally on F####= normally off  First two digits= Qty. 01 to 99 max (specify) Last two digits= Amp rating 10, 15, 20, 25... (specify)	A= fast recovery charge B= remote meter panel C= remote alarm panel D= ethernet port E= output trip alarm F= NEXUS® system interface G= "inverter on" dry contact H= normally off full capacity output I= extended battery warranty* J= external maintenance bypass K= seismic mounting bracket L= drip shield M= second output terminal block N= normally on & normally off output** * Consult your sales representative. ** Full capacity available on either output

EXAMPLE: E1A3N1020

Project/Location:

Contractor:

Date:

Prepared by:

# IPS SINGLE PHASE SERIES

Interruptible emergency lighting inverter system 3KVA –15KVA

## SYSTEM SPECIFICATIONS

### GENERAL

<b>DESIGN</b>	Stand-by, PWM inverter type utilizing Power Mosfet technology with 500ms transfer time.
<b>CONTROL</b>	Microprocessor controlled, 4 x 20-character display with touch pad controls & functions
<b>METERING</b>	Input & Output Voltage, Battery Voltage, Battery & Output Current, Output VA, Temperature
<b>COMMUNICATIONS</b>	RS-485 MODBUS RTU Port (DB-9)

### ELECTRICAL INPUT

<b>VOLTAGE</b>	120, 277, 347VAC 2-wire or 120/240VAC 3-wire, 1-phase, +10%/ -15%
<b>INPUT FREQUENCY</b>	60Hz

### ELECTRICAL OUTPUT

<b>VOLTAGE</b>	120, 277, 347VAC 2-wire or 120/240 3-wire, 1-phase
<b>DYNAMIC VOLTAGE</b>	+/-2% for +/-25% load step change, +/-3% for a 50% load step change, recovery within 3 cycles
<b>HARMONIC DISTORTION</b>	<5% THD for linear load
<b>OUTPUT FREQUENCY</b>	60Hz +/- 2Hz during emergency mode
<b>LOAD POWER FACTOR</b>	0.7 lag to 0.9 lead
<b>INVERTER OVERLOAD</b>	120% continuous, 150% for 1 minute and 200% for 10 seconds
<b>PROTECTION</b>	Optional External Distribution Circuit Breaker
<b>CREST FACTOR</b>	3

### ENVIRONMENTAL CONDITIONS

<b>STORAGE/TRANSPORT</b>	32°F to 104°F (0°C to 40°C) without batteries 68°F to 86°F (20°C to 30°C) with batteries <sup>(1)</sup>
<b>OPERATING TEMPERATURE</b>	System operates safely from 32°F to 104°F (0°C to 40°C) but optimum operation is between 68°F and 77°F (20°C to 25°C). Battery performance can be affected by temperature.
<b>ALTITUDE</b>	<10,000 feet (above sea level) without de-rating
<b>RELATIVE HUMIDITY</b>	0 to 95% non-condensing
<b>AUDIBLE NOISE</b>	45 dBA at 1m from surface in emergency mode

(1) - max. 3 months at 77°F-86°F (25°C-30°C)

## SINGLE LINE DIAGRAM

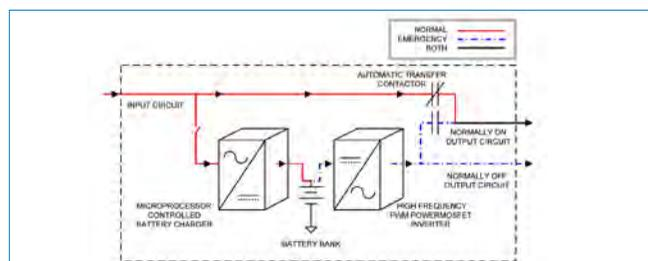

### CABINETS

Modular design, freestanding NEMA type 1 steel cabinets powder coated for corrosion and scratch resistance. Front access design through hinged lockable doors requires only 42" front, 2" back and side clearance and 12" top clearance without drip shield. Top conduit entry Gland Plate.

### INVERTER

Using Power Mosfet/PWM technology the inverter converts DC voltage supplied by the batteries to AC voltage of a precise stabilized amplitude and frequency, suitable for most sophisticated electrical equipment. True sinusoidal output waveform with very low distortion (less than 5% for linear loads). Overload capability of 120% continuous, 150% for 1 minute and 200% for 10 seconds.

### CHARGER

Fully automatic, temperature compensated, charger recharges fully discharged batteries in maximum 24 hours at nominal AC input voltage. AC input current limiting and over-voltage protection included.

### BATTERY

System is provided standard with 10 year, maintenance free, sealed valve regulated, lead calcium batteries. 30, 60, 90 & 120 min. standard discharge time at full load under normal operating temperature (20°C to 25°C). Low Voltage Disconnect protection included. No special ventilation required.

### SUPERVISION

Automatic self tests consist of a 2-minute monthly, 1/3 discharge at 6 months and full annual discharge. The front-mounted control panel includes, a 4-line 20-character LCD display with a keypad to control and monitor the operation of the system. This allows the operator to easily "watch" system functions as they occur and check on virtually any aspect of the system's operation. Standard RS485 MODBUS RTU diagnostic interface.

### ALARMS

Battery High/Low, Low Voltage Disconnect, Battery Disconnect, Maintained Lamp Off, Charger Fail, Supply From Battery, System Inhibit, Circuit Breaker Trip, Module Breaker Trip, Inverter Undervoltage, Inverter Overvoltage, Output Overcurrent, Hi Temp, Over Temp, Unit in Bypass, Inverter Frequency Control Failed, Processor Reset.

### OPTIONAL FEATURES

External Output Circuit Breakers, Output Trip Alarms, Extended Battery Warranty, 12 Hours Fast Recharge, External Maintenance Bypass Switch, Remote Meter Panel, Ethernet Port, Nexus® System Interface, Dripshield, Remote Alarm Panel, Normally Off Output, Seismic Mounting Brackets, Dry Contact Relay.

### FACTORY START-UP

Includes one additional year of warranty. See warranty conditions.

### WARRANTY

(full limited warranty conditions available upon request)

Limited manufacturer warranty is one-year, parts and labor, for system electronics. Battery warranty is one year full plus 9 years pro-rata for a total of 10 years, under normal operating conditions. System must be put in service within 6 months from ship date in order to validate warranty. Consult factory for other battery types.

# IPS THREE PHASE SERIES

Interruptible emergency lighting inverter system 4.5KVA –54KVA

Project/Location: \_\_\_\_\_

Contractor: \_\_\_\_\_

Date: \_\_\_\_\_

Prepared by: \_\_\_\_\_



## FEATURES

- PWM/Power Mosfet technology
- Self-testing/Self-diagnostic
- User programmable with password protection
- User programmable variable time delay
- Optional 100% normally Off output
- RS485 MODBUS RTU communication port
- Micro-processor controlled
- 30, 60, 90, 120 minutes run times
- Summary alarm form C dry contact
- Generator compatibility
- Electronic and magnetic ballast compatible
- Automatic event, test and alarm log
- LCD display
- Maintenance free standard batteries
- Forced air cooling during emergency and recharge modes only
- Off when on standby

## ELECTRICAL/MECHANICAL CHARACTERISTICS FOR 30 MINUTES BACK-UP TIME

POWER RATING KVA/KW	EFFIC. AT FULL LOAD %	MAX. INPUT CURRENT (All1)			HEAT LOSS IN NORMAL MODE (BTU/HR)	BATT. VDC	BATT. ADC	NO. OF BATT. (1)	NO. OF IPS CAB. (1)(2)	IPS CABINET DIMENSIONS			NO. OF 20 BATT. CAB. (1)(2)	BATT. CABINET DIMENSIONS			NO. OF 30 BATT. CAB. (1)(2)	BATT. CABINET DIMENSIONS			TOTAL IPS CABINET WEIGHT KG (1)(2)	TOTAL BATT. CABINET WEIGHT KG (EMPTY)(1)	BATTERY WEIGHT KG (1)	TOTAL SYSTEM WEIGHT KG (1)
		208/120V	480/277V	600/347V						W"	H"	D"		W"	H"	D"		W"	H"	D"				
4.5	98%	29	13	10	546	120	50	20	1	30	71	27	NA	NA	NA	NA	NA	NA	NA	265	NA	210	475	
9.0	98%	42	18	14	546	120	101	10	1	30	71	27	NA	NA	NA	NA	NA	NA	NA	340	NA	372	712	
13.5	98%	54	23	19	546	120	151	20	1	30	77	27	1	30	77	27	NA	NA	NA	415	140	550	1105	
18.0	98%	67	29	23	546	120	202	20	1	30	77	27	1	30	77	27	NA	NA	NA	540	140	744	1424	
22.5	98%	79	34	27	546	120	252	30	1	30	77	27	NA	NA	NA	1	30	71	30	615	165	825	1605	
27.0	98%	92	40	32	546	120	303	30	1	30	77	27	NA	NA	NA	1	30	77	30	690	165	1116	1971	
31.5	98%	104	45	36	1092	120	353	30	2	30	77	27	1	30	77	27	NA	NA	NA	905	140	1116	2161	
36.0	98%	117	51	40	1092	120	403	40	2	30	77	27	NA	NA	NA	1	30	77	30	1030	165	1488	2683	
40.5	98%	129	56	45	1092	120	454	40	2	30	77	27	2	30	77	27	NA	NA	NA	1105	280	1488	2873	
45.0	98%	142	61	49	1092	120	504	50	2	30	77	27	1	30	77	27	1	30	77	30	1180	305	1860	3345
49.5	98%	NA	67	53	1092	120	555	50	2	30	77	27	1	30	77	27	1	30	77	30	1255	305	1860	3420
54.0	98%	NA	73	58	1092	120	605	60	2	30	77	27	NA	NA	NA	2	30	77	30	1380	330	2232	3942	

1- For 30 min. discharge time. For other discharge times, consult factory.  
 2- Batteries are installed in the IPS cabinet for 4.5 to 9.0KVA systems, for 30 minutes only.

## ORDERING INFORMATION<sup>(1)</sup>

SERIES	SYSTEM VOLTAGE	KVA/KW	RUN TIME	EXTERNAL CIRCUIT BREAKER	OPTIONS
EIII= Series	1= 120/208 4 wire in-out 2= 277/480 3= 347/600	A= 4.5 B= 9 C= 13.5 D= 18 E= 22.5 F= 27 G= 31.5 H= 36 I=40.5 J= 45** K= 49.5* L= 54*	3= 30 minutes 6= 60 minutes 9= 90 minutes 12= 120 minutes	B= no breakers N####= normally on F####= normally off  First two digits= Qty. 01 to 99 max (specify) Last two digits= Amp rating 10, 15, 20, 25... (specify)  Example: N1020	A= fast recovery charge B= remote meter panel C= remote alarm panel D= ethernet port E= output trip alarm F= NEXUS® system interface G= "inverter on" dry contact H= normally off full capacity output I= extended battery warranty* J= external maintenance by pass K= seismic mounting bracket L= drip shield M= second output terminal block N= normally on & normally off output** * Consult your sales representative. ** Full capacity available on either output

EXAMPLE: EIII1A3N1020

Project/Location: \_\_\_\_\_

Contractor: \_\_\_\_\_

Date: \_\_\_\_\_

Prepared by: \_\_\_\_\_

# IPS THREE PHASE SERIES

Interruptible emergency lighting inverter system 4.5KVA –54KVA

## SYSTEM SPECIFICATIONS

### GENERAL

<b>DESIGN</b>	Stand-by. PWM inverter type utilizing Power Mosfet technology with 500ms transfer time.
<b>CONTROL</b>	Microprocessor controlled, 4 x 20-character display with touch pad controls & functions
<b>METERING</b>	Input & Output Voltage, Battery Voltage, Battery & Output Current, Output VA, Temperature
<b>COMMUNICATIONS</b>	RS-485 MODBUS RTU Port (DB-9)

### ELECTRICAL INPUT

<b>VOLTAGE</b>	120/208, 277/480, 347/600VAC 3-phase 4-wire +10% / -15%.
<b>INPUT FREQUENCY</b>	60Hz

### ELECTRICAL OUTPUT

<b>VOLTAGE</b>	120/208, 277/480, 347/600VAC 3-phase 4-wire.
<b>DYNAMIC VOLTAGE</b>	+/-2% for +/-25% load step change, +/-3% for a 50% load step change, recovery within 3 cycles
<b>HARMONIC DISTORTION</b>	<5% THD for linear load
<b>OUTPUT FREQUENCY</b>	60Hz +/- 2Hz during emergency mode
<b>LOAD POWER FACTOR</b>	0.7 lag to 0.9 lead
<b>INVERTER OVERLOAD</b>	120% continuous, 150% for 1 minute and 200% for 10 seconds
<b>PROTECTION</b>	Optional External Distribution Circuit Breaker
<b>CREST FACTOR</b>	3

### ENVIRONMENTAL CONDITIONS

<b>STORAGE/TRANSPORT</b>	32°F to 104°F [0°C to 40°C] without batteries 68°F to 86°F [20°C to 30°C] with batteries <sup>(1)</sup>
<b>OPERATING TEMPERATURE</b>	System operates safely from 32°F to 104°F [0°C to 40°C] but optimum operation is between 68°F and 77°F [20°C to 25°C]. Battery performance can be affected by temperature.
<b>ALTITUDE</b>	<10,000 feet (above sea level) without de-rating
<b>RELATIVE HUMIDITY</b>	0 to 95% non-condensing
<b>AUDIBLE NOISE</b>	45 dBA at 1m from surface in emergency mode

(1) - max. 3 months at 77°F-86°F [25°C-30°C]

## SINGLE LINE DIAGRAM

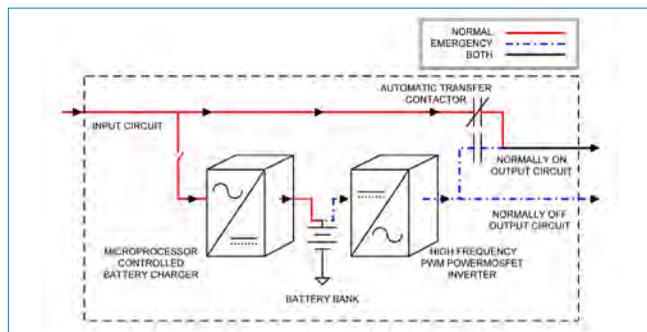

### CABINETS

Modular design, freestanding NEMA type 1 steel cabinets powder coated for corrosion and scratch resistance. Front access design through hinged lockable doors requires only 42" front, 2" back and side clearance and 12" top clearance without drip shield. Top conduit entry Gland Plate.

### INVERTER

Using Power Mosfet/PWM technology the inverter converts DC voltage supplied by the batteries to AC voltage of a precise stabilized amplitude and frequency, suitable for most sophisticated electrical equipment. True sinusoidal output waveform with very low distortion (less than 5% for linear loads). Overload capability of 120% continuous, 150% for 1 minute and 200% for 10 seconds.

### CHARGER

Fully automatic, temperature compensated, charger recharges fully discharged batteries in maximum 24 hours at nominal AC input voltage. AC input current limiting and over-voltage protection included.

### BATTERY

System is provided standard with 10 year, maintenance free, sealed valve regulated, lead calcium batteries. 30, 60, 90 & 120 min. standard discharge time at full load under normal operating temperature (20°C to 25°C). Low Voltage Disconnect protection included. No special ventilation required.

### SUPERVISION

Automatic self tests consist of a 2-minute monthly, 1/3 discharge at 6 months and full annual discharge. The front-mounted control panel includes, a 4-line 20-character LCD display with keypad to control and monitor the operation of the system. This allows the operator to easily "watch" system functions as they occur and check on virtually any aspect of the system's operation. Standard RS485 MODBUS RTU diagnostic interface.

### ALARMS

Battery High/Low, Low Voltage Disconnect, Battery Disconnect, Maintained Lamp Off, Charger Fail, Supply From Battery, System Inhibit, Circuit Breaker Trip, Module Breaker Trip, Inverter Undervoltage, Inverter Overvoltage, Output Overcurrent, Hi Temp, Over Temp, Unit in Bypass, Inverter Frequency Control Failed, Processor Reset.

### OPTIONAL FEATURES

External Output Circuit Breakers, Output Trip Alarms, Extended Battery Warranty, 12 Hours Fast Recharge, External Maintenance Bypass Switch, Remote Meter Panel, Ethernet Port, NEXUS® System Interface, Dripshield, Remote Alarm Panel, Normally Off Output, Seismic Mounting Brackets, Dry Contact Relay.

### FACTORY START-UP

Includes one additional year of warranty. See warranty conditions.

### WARRANTY

(full limited warranty conditions available upon request)

Limited manufacturer warranty is one-year, parts and labor, for system electronics. Battery warranty is one year full plus 9 years pro-rata for a total of 10 years, under normal operating conditions. System must be put in service within 6 months from ship date in order to validate warranty. Consult factory for other battery types.

# Systems Options

## Details

Project/Location:

Contractor:

Date:

Prepared by:

### **(-A) 12 HOUR FAST RECHARGE**

Battery charger upgrade option which decreases the time required to recharge a fully discharged battery to a fully charged state. The normal 24 hour recharge time is reduced to a 12 hour period.

### **(-B) REMOTE METER PANEL**

The panel allows monitoring of parameters and control from remote locations up to 200 feet away from the inverter system. Also, the remote panel provides a complete touch pad interface allowing the user to monitor, control and program the inverter system.

### **(-C) REMOTE SUMMARY ALARM PANEL**

Wall mountable box provides visual and audible alarms with silence switch. The panel consists of LED indicators and built in audible alarm and may be located up to 1,000 feet away from the inverter system.

### **(-D) ETHERNET PORT**

Interface to ethernet network. Provides status information and allows system management via internet browser.

### **(-E) OUTPUT TRIP ALARM**

System triggers an alarm when any output breaker trips.

### **(-F) NEXUS® SYSTEM INTERFACE**

Allows remote monitoring of the system from a server (wireless or cabled communication).

### **(-G) INVERTER ON DRY CONTACTS**

Form C dry contacts that will change state when the system transfers to battery.

### **(-H) NORMALLY OFF OUTPUT**

This output circuit is dedicated for the emergency only equipment. Emergency only equipment operates during power outages and when the system is on battery back up. This option leaves the normally off load circuits off during normal utility power conditions.

### **(-I) EXTENDED BATTERY WARRANTY**

Extends battery warranty from 10 years pro-rated to 20 years pro-rated.

### **(-J) EXTERNAL MAINTENANCE BYPASS SWITCH**

The external maintenance bypass switch is mounted in a maximum of 42"H x 36"W x 12"D NEMA 1 separate enclosure, used to completely isolate the inverter system from the connected load and AC utility input. This option allows the system to be safely powered down for maintenance or service.

### **(-K) SEISMIC MOUNTING KIT**

The seismic mounting kit option is designed to prevent system movement during seismic events. Heavy duty brackets are provided to secure system cabinetry to your surfaces.

### **(-L) DRIP SHIELD**

Hood cover to protect the enclosure against falling water from sprinkler systems.

### **(-M) SECOND OUTPUT TERMINAL BLOCK**

The output of the Central System is divided into two. The load can be connected to either outputs.

### **(-N) NORMALLY ON & NORMALLY OFF OUTPUTS**

The Central System can have both normally on and normally off outputs. Either output can handle 100% of the load.

Project/Location:

Contractor:

Date:

Prepared by:

# User Interface & Display Functions

## METER & READING FUNCTIONS MENU

- AC Voltage Output
- AC Current Output Normally On
- AC Current Output Normally Off
- Battery Voltage
- Battery Charging Current
- Battery Discharging Current
- KVA Total Output
- Cabinet Internal Temperature
- Inverter Frequency
- Real Time Clock
- Time Delay
- Monthly Test Result
- Half Year Test Result
- Annual Test Result
- Event Log Reading

## SERVICE MENU FUNCTIONS

- Passkeyword protected
- Set Battery Voltage & Current Ranges
- Set System Voltage & Current Ranges
- Set System Phase
- Set Normally OFF Load
- Set Language
- Set Real Time Clock & Calendar
- Set Time Delay Function
- Set Manual Test Duration
- Set Self Test Sequence
- Set Buzzer Function



## ADMINISTRATION MENU FUNCTIONS

- Passkeyword protected
- Read/Set Serial Number
- Read/Set Manufacturing Date
- Read/Set Installation Date
- Read Firmware Version
- Read/Clear Battery Elapse Time
- Read/Clear Total Power Failures
- Read/Clear Total Alarms
- Clear Event Log
- Enter Calibration Routine

## ALARM AND EVENTS

- Event Logging (1000) Type Date & Hour
- Transfer Mode
- Standby
- Load Off
- Stop Mode
- Lock-Out Mode
- Forced Transfer
- Battery Volt
- Battery Disconnect
- Mains Out Of Range
- Manual Test
- Monthly Test
- Half Year Test
- Yearly Test
- Modbus Transfer

## SYSTEM TESTING

EMEX Central Battery Systems provide manual and automatic test functions. Manual test can be activated any time using the test key provided on the control panel. Manual testing will do a programmable fixed test time and can be aborted any time by pushing again on the test key. Automatic test and diagnostic is done following an annual sequence. Every month a quick diagnostic test of 2 minutes is performed. At the 6 month mark, a 1/3 timed discharge test is done, and at the 12 month, a full discharge, down to LVD is performed. Pass/Fail and discharge time are registered in the event log. Test time and date is programmed using the Service Menu.

# Central System Request Data

Project/Location:	_____
Contractor:	_____
Date:	_____
Prepared by:	_____

## 1) INPUT VOLTAGE

- |                                  |                                     |                                     |                                     |                                 |
|----------------------------------|-------------------------------------|-------------------------------------|-------------------------------------|---------------------------------|
| Single phase (2 wire + ground)   | 120VAC <input type="checkbox"/>     | 208VAC <input type="checkbox"/>     | 277VAC <input type="checkbox"/>     | 347VAC <input type="checkbox"/> |
| Single phase (3 wire + ground)   | 120/240VAC <input type="checkbox"/> |                                     |                                     |                                 |
| Three phase (4 wire + ground, Y) | 120/208VAC <input type="checkbox"/> | 277/480VAC <input type="checkbox"/> | 347/600VAC <input type="checkbox"/> |                                 |
| Three phase (3 wire + ground, Δ) | 208VAC <input type="checkbox"/>     | 480VAC <input type="checkbox"/>     | 600VAC <input type="checkbox"/>     |                                 |

## 2) OUTPUT VOLTAGE

- |                                  |                                     |                                     |                                     |                                 |
|----------------------------------|-------------------------------------|-------------------------------------|-------------------------------------|---------------------------------|
| Single phase (2 wire + ground)   | 120VAC <input type="checkbox"/>     | 208VAC <input type="checkbox"/>     | 277VAC <input type="checkbox"/>     | 347VAC <input type="checkbox"/> |
| Single phase (3 wire + ground)   | 120/240VAC <input type="checkbox"/> | 120/277VAC <input type="checkbox"/> |                                     |                                 |
| Three phase (4 wire + ground, Y) | 120/208VAC <input type="checkbox"/> | 277/480VAC <input type="checkbox"/> | 347/600VAC <input type="checkbox"/> |                                 |

## 3) SYSTEM CAPACITY

KVA rating: \_\_\_\_\_

- a) Please consider total power consumption of the complete fixture, not just the lamp wattage  
 b) Even if the systems can run with 100% load, it is recommended as standard practice to use a system with a capacity at least 20% over maximum connected load

## 4) RUNTIME

- 30 minutes       60 minutes       90 minutes       120 minutes  
 Other \_\_\_\_\_

## 5) TYPE OF LOADS

- Incandescent       Fluorescent       L.E.D.  
 Others \_\_\_\_\_

## 6) MODE OF OPERATION

- Normally ON (24/7)       Normally OFF (emergency only)

## 7) OUTPUT CIRCUIT BREAKERS

- |               |            |                  |  |   |                                     |
|---------------|------------|------------------|--|---|-------------------------------------|
| # of CB _____ | Amps _____ | # of poles _____ | Normally "On" <input type="checkbox"/> | Normally "Off" <input type="checkbox"/> | Trip alarm <input type="checkbox"/> |
| # of CB _____ | Amps _____ | # of poles _____ | Normally "On" <input type="checkbox"/> | Normally "Off" <input type="checkbox"/> | Trip alarm <input type="checkbox"/> |

## 8) OPTIONS (REFER TO AVAILABLE OPTIONS FOR EACH SYSTEM TYPE)

- |  |  |
|--|--|
| <input type="checkbox"/> [-A] 12 Hour Fast Recharge      | <input type="checkbox"/> [-H] Normally Off Output                |
| <input type="checkbox"/> [-B] Remote Meter Panel         | <input type="checkbox"/> [-I] Extended Battery Warranty          |
| <input type="checkbox"/> [-C] Remote Summary Alarm Panel | <input type="checkbox"/> [-J] External Maintenance Bypass Switch |
| <input type="checkbox"/> [-D] Ethernet Port              | <input type="checkbox"/> [-K] Seismic Mounting Kit               |
| <input type="checkbox"/> [-E] Output Trip Alarm          | <input type="checkbox"/> [-L] Drip Shield                        |
| <input type="checkbox"/> [-F] NEXUS® System Interface    | <input type="checkbox"/> [-M] Second Output Terminal Block       |
| <input type="checkbox"/> [-G] Inverter On Dry Contacts   | <input type="checkbox"/> [-N] Normally On & Normally Off outputs |

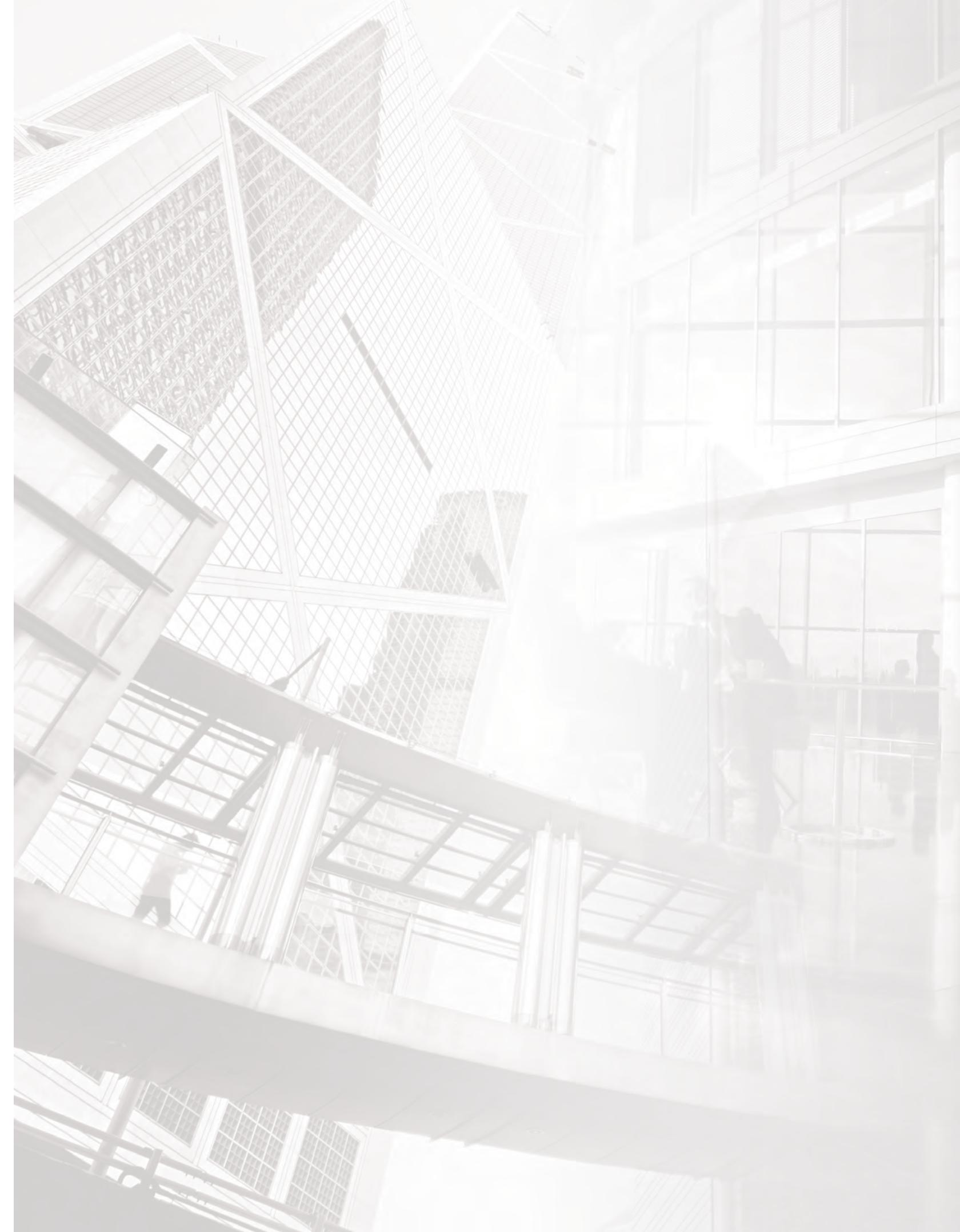



# Unity Series

120VDC Central Single Source  
Emergency Lighting System

Project/Location:	_____
Contractor:	_____
Date:	_____
Prepared by:	_____

## Time and labour saver only one conduit required!

In an existing or new installation where exit signs and emergency lighting may be supplied by a single 120VDC source using a common negative wire, one normally on positive and one normally off positive. 3 wire output from the system reduces the number of conductors by up to 40%. It also eliminates 50% of the conduit, EMT or BX runs by using a single common conduit for LED exits and emergency lighting remotes.

## FEATURES

- Single-source 120VDC supply for both exit and emergency lights
- Reduced number of conductors
- Eliminates 50% of conduit, BX or EMT runs for exit and emergency lighting
- Control and supervision functions on single modular board
- Complete package of full supervisory functions and alarms included in standard unit
- Floor-mount cabinet
- Battery is sealed maintenance free lead calcium
- All **Unity Series** systems are designed and manufactured in Canada
- CSA and Ontario Hydro approved
- BMEC (Building Materials Evaluation Commission) approved for compliance to the Ontario Building Code
- Overall reduction on power consumption using LED Exit Signs

## OPERATIONS

**Unity Series** Central Emergency Lighting Systems are available in free-standing cabinet style enclosures

- Heavy duty, sheet-steel cabinet
- Cabinets are painted ASA No. 61 grey electrolyte resistant enamel
- Locking and hinged front door
- Front access to battery charger for ease of inspection and servicing

## CHARGER CONTROLS

**Emergi-lite®**'s solid state fully automatic charger features single module control board design. This feature provides cost effective superior performing equipment, with ease of maintenance and service ability.

## STANDARD FEATURES AND CONTROLS

- LVD at 91% of nominal
- Temperature Compensation
- Ground Fault Alarm (Audible & Visual)
- DC Volt & Ammeter (2% Accuracy)
- AC present LED indicator
- Float level Charge LED indicator
- Equalize level Charge LED indicator
- Charger Failure Alarm
- AC Failure Alarm
- High Battery Voltage Alarm
- Test Switch
- Remote Monitor Alarm Panel
- Brownout Protection
- Dry Contacts
- BMEC - Ontario Building Materials Evaluation Commission Approved
- SPF - sprinkler-proof cabinet comes with drip shield

## OPTIONAL FEATURES CODE

• Time Delay	TD
• 3 Phase Sensing	3PH
• 12 Hour Recharge	12HR
• Battery exerciser	CYC
• Input battery circuit breaker	BCB
• Common Zone sensing	ZSC

## APPLICATION

New construction or retro-fit, the **Unity Series** utilizes the latest technology and engineering to reduce the cost of emergency lighting installations. The unique 3 wire design allows for the use of just one conduit. With one positive dc normally energized conductor and a common negative conductor the LED exits are supplied constant power. With the same common negative conductor and another positive DC conductor the remote emergency lights are powered on demand. Available in sizes from 4120W to 22520W for 30 minutes. Other runtimes available. Please consult factory.

## ELECTRICAL

**Input:** 120V, 208V, 240V, 277V, 347V, 600VAC 60HZ Single Phase

**Output:** 120VDC 3 wire (normally on positive, common negative and normally off positive).

Systems have been designed for minimum 1/2 hour operation time and are capable of full recharge in 24 hours. For systems rating chart and ordering guide please see next page. Other discharge times are available upon request.



Project/Location:

Contractor:

Date:

Prepared by:

# Unity Series

## 120VDC Central Single Source Emergency Lighting System



### WARRANTY

The complete system is guaranteed for a period of one (1) year against defects in workmanship and materials. The battery portion of the equipment carries a ten (10) year pro-rata warranty during its useful service life against defects in workmanship and materials. The battery warranty is subject to the provision of normal testing and inspection as specified in the Canadian Electrical Code, Section 46-102, and National Fire Code of Canada. Limit room ambient temperature between 20°C to 25°C (68°F to 77°F). Optimum system performance occurs at 25°C (77°F). A battery service life is defined as the period which the battery could still provide at least 80% of its rated capacity.

### APPROVALS

- CSA Certified
- Ontario Hydro: Rule 46-108 (3)

### ENCLOSURE DIMENSIONS

SYSTEM SERIES	H X W X D
UNI 4120	38" (96.5 cm) x 38" (96.5 cm) x 18" (45.7 cm)
UNI 5660-11260	38" (96.5 cm) x 38" (96.5 cm) x 28" (71.1 cm)
UNI 13140-22520	56" (142.2 cm) x 38" (96.5 cm) x 28" (71.1 cm)

### UNIT RATING

**SL Series batteries:** maintenance free, sealed Lead-Calcium. Watts at 91% of nominal voltage.

CAPACITY IN WATTS	30 MIN	1H00	1H30	2H00
UNI 4120	4 120	2 450	1 790	1 440
UNI 5660	5 660	4 015	2 935	2 355
UNI 9390	9 390	5 590	4 080	3 290
UNI 11260	11 260	6 700	4 890	3 940
UNI 13140	13 140	7 820	5 710	4 600
UNI 18780	18 780	11 180	8 160	6 580
UNI 22520	22 520	13 400	9 780	7 880

### ORDERING INFORMATION

SYSTEM DESIGNATION	A.C. INPUT VOLTAGE (1PH)	BATTERY TYPE	CAPACITY IN WATTS	QTY OF EXIT SIGNS	MOUNTING	D.C. OUTPUT VOLTAGE	OPERATING TIME	OPTIONS
UNI	120= 120VAC 208= 208VAC 240= 240VAC 277= 277VAC 347= 347VAC 600= 600VAC	SG = sealed Lead Calcium	_____*	50E= 50 Exit Signs  100E= 100 Exit Signs	C= Console	120= 120VDC	30= 30 minutes 60= 60 minutes 90= 90 minutes 120= 120 minutes	TD= Time delay (15 minutes)* 3PH= 3 phase sensing 12HR= 12 hour recharge CYC= Battery exerciser BCB= Battery circuit breaker ZSC= Common zone sensing** * Specify time. ** Specify No. of zones.

\*Select from Battery Capacity chart in folder

For other discharge times, please consult your sales representative.

### TYPICAL INTERCONNECTION WIRING DIAGRAM

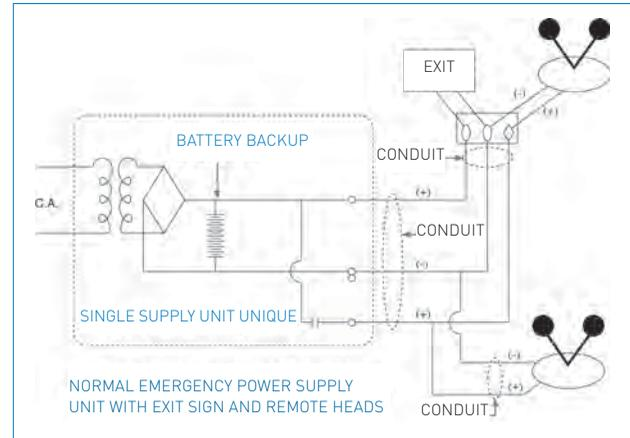

CAD Drawing illustrates how the Unity Series is applied, saving time, material and money. Call your local Emergi-Lite® Representative for further information, or application assistance.





# CH Series

DC Central Emergency Lighting System

Project/Location:
Contractor:
Date:
Prepared by:

## Fully automatic charger, battery and specified transfer and distribution features

**Emergi-Lite**®'s DC Systems are utilized where a large number of remote heads or standard 120V incandescent fixtures may be supplied from a single source. The systems offer the advantage of a central location for maintenance with full supervision of all operating functions. Contact your **Emergi-Lite**® representative for information.

### FEATURES

- 24, 36 and 120 VDC systems sealed lead acid batteries
- Control and supervision functions on single modular board
- Complete package of full supervisory functions and alarms included in standard system
- Totally sealed maintenance free Lead Calcium batteries
- All systems are designed and manufactured in Canada
- CSA certified
- BMEC (Building Materials Evaluation Commission) approved for compliance to the Ontario Building Code

### BATTERY

#### Sealed Maintenance-Free Lead Calcium Gas Recombination (SL Series)

Uses gas recombination to eliminate the escape of hydrogen. Thick plates are constructed of high strength material which resists shedding, flaking, or mechanical failure. Design Life: 10 years under normal operating conditions.

### CHARGER FEATURES

**Emergi-Lite**® has developed a unique modular charger design in which all electronic control functions and pilot lights are mounted on a single control board. This is connected to the operating power components using screw type connectors— making the circuit board easily removable by means of only four screws. Any required field service, consequently, is faster and significantly simpler than with older style multiple board designs. All chargers include a contactor which automatically disconnects the batteries from the load when battery bank voltage falls below 91% of nominal, in order to prevent over-discharge of batteries. The operating temperature for the system is from 20°C to 25°C (68°F to 77°F). The control board is temperature compensated in order to meet the battery required float voltage at temperatures below and above 25°C, as recommended by battery manufacturers. Internal control allows for spark free battery bank connection during installation and scheduled maintenance procedures.

### CHARGING OPERATION

The charger will fully recharge the battery within a twenty four hour period from a full discharge. The charger maintains regulation of  $\pm 0.5\%$  of voltage for a  $\pm 10\%$  input voltage variation. The charger provides automatic equalize cycle whenever the charge current is more than a preset value. The charger operates in an equalize mode after each utility power return. This ensures maximum battery capacity at all times, with maintained life expectancy

### STANDARD CONTROLS

The front panel includes the following controls:

- DC Battery Voltmeter (2% Accuracy)
- DC Charge Rate Ammeter (2% Accuracy)
- Green "ac on" LED (on at all times except during power failure)
- Green "float" LED (indicates that the battery is receiving float charge to maintain the battery at full charge at all times)
- Amber "equalize" LED (indicates that the charger is in the high charge equalize mode, balancing the charge level in the individual battery cells)
- Brown-out protection
- Test switch
- A.C input circuit breaker

### STANDARD ALARMS

- AC Failure LED and Alarm
- High Battery Voltage LED and Alarm
- Charger Failure LED and Alarm
- Ground Leakage Alarm
- An audible alarm and a common LED shall indicate "Ground Leakage" and/or Fuse/Circuit Breaker open/trip alarm
- High ambient temperature

### DISTRIBUTION OPTIONS

A separate distribution panel is available for all systems. A choice of fuses or circuit breakers is available. Fuse Distribution Panel Select -OPF ( ) for separate distribution fuse panel. Select -OFA ( ) for separate distribution fuse panel with visual and audible alarm on main console for failure of any fuse.

Note: "( )" indicates the number of circuits required.

Circuit Breaker Distribution Panel Specify - CBO ( ) for separate circuit breaker panel. Specify - OCA ( ) for separate circuit breaker panel with visual and audible alarm on main console for tripping or opening of any breaker.



Project/Location:	_____
Contractor:	_____
Date:	_____
Prepared by:	_____

# CH Series

## DC Central Emergency Lighting System



### TRANSFER OPTIONS

- System may be selected to either turn on a normally "off" load or alternatively on 120VDC systems, maintain a normally "on" load
- Normally "off" (DC load): (CP)
- If the lamp load is going to be turned on in the event of power failure add suffix -CP to the model number
- Normally "on" (AC/DC load): (TS) 120 V DC systems only
- The 120V incandescent load shall have 120VAC power normally supplied to it and the load shall be transferred to 120VDC upon failure. Add suffix -TS to the model number. For other AC input voltages please contact factory
- Both Normally "on" & "off" loads: (CP/TS)
- Both of the above apply

### OTHER OPTIONS

CODE	DESCRIPTION
Time delay	TD
3 phase sensing	3PH
Battery circuit breaker	BCB
Battery exerciser	CYC
Common Zone Sensing	ZSC( )*
Individual zone sensing, specify number of zones	ZSI( )*

\* Zone explanation: each specified zone relay monitors an individual lighting circuit in a building. Should the monitored circuits lose AC power, the connected lighting load will automatically illuminate:

- a - all zones if ZSC is specified
- b - that zone only if ZSI is specified

### CABINETS

Systems are available in a free standing floor mount cabinet. The cabinet shall be constructed of not less than 14 gauge steel with corrosion resistant undercoating. Standard finish is ASA61 grey baked enamel.

### WARRANTY

The complete system is guaranteed for a period of one (1) year against defects in workmanship and materials. The battery portion of the equipment carries a ten (10) year pro-rata warranty during its useful service life against defects in workmanship and materials. The battery warranty is subject to the provision of normal testing and inspection as specified in the Canadian Electrical Code, Section 46-102, and National Fire Code of Canada. Limit room ambient temperature between 20°C to 25°C (68°F to 77°F). Optimum system performance occurs at 25°C (77°F). A battery service life is defined as the period which the battery could still provide at least 80% of its rated capacity.

### TYPICAL SPECIFICATION

Provide and install a complete emergency lighting system as described herein and shown on the drawings. The system shall consist of a charger, battery and specified transfer and distribution features. The charger shall be fully automatic solid state type using integrated circuit control. The output voltage variation shall be  $\pm 0.5\%$  for input variation of  $\pm 10\%$ . The charger shall recharge the battery within 24 hours after a power failure. The charger shall include a contactor to automatically disconnect the battery from the load when the battery voltage falls below 91% of nominal. The charger shall be of a modular design with all pilot lights and electronic control functions on a single board mounted behind the front panel. The single control board shall have LED pilot lights for the following functions (which shall show through the front panel):

- Green "ac on" LED
- Green "float" Charge LED
- Amber "equalize" LED
- The single control board shall also include LED and an audible alarm with call-back function for the following alarms:
  - AC Failure
  - High Battery Voltage
  - Charger Failure
  - Battery Ground Leakage
  - High ambient temperature

### OPTIONAL ALARMS

- Fuse/Circuit Breaker Open/Trip

### SELECT SL BATTERY

Select battery bank voltage, capacity and duration of required backup time. Select AC input voltage. Select system transfer option from CP ( ), TS ( ), or CP ( )/TS ( ) where the load watts are shown in brackets.

### SELECT OPTIONS

The equipment shall be provided with a separate distribution panel with \_\_\_\_\_ fuses or circuit breakers (select one) rated at \_\_\_\_\_ Amps.

Optional: All distribution fuse or circuit breaker panels shall be alarmed so that if a fuse or circuit breaker has failed during operation, a visual and audible alarm is activated. The system shall be – **Emergi-Lite®** System CH (select model number from ordering information chart). Select remote fixture from fixture section of Catalogue.



# CH Series

DC Central Emergency Lighting System

Project/Location: \_\_\_\_\_

Contractor: \_\_\_\_\_

Date: \_\_\_\_\_

Prepared by: \_\_\_\_\_

## SG SERIES :

### Battery Capacity Chart

MODEL	NOMINAL BACKUP CAPACITY				
	30 MIN	60 MIN	90 MIN	120 MIN	
A	CH24SG820	820W	490W	355W	285W
B	CH24SG1280	1130W	800W	585W	470W
C	CH24SG1875	1875W	1115W	815W	655W
D	CH24SG2250	2250W	1340W	975W	785W
E	CH24SG2625	2625W	1560W	1140W	920W
F	CH24SG3755	3755W	2235W	1630W	1315W
G	CH36SG1230	1230W	730W	537W	432W
H	CH36SG1920	1695W	1205W	880W	705W
I	CH36SG2815	2815W	1675W	1220W	985W
J	CH36SG3375	3375W	2010W	1465W	1180W
K	CH36SG3940	3940W	2345W	1710W	1380W
L	CH120SG4120	4120W	2450W	1790W	1440W
M	CH120SG5660	5660W	4015W	2935W	2355W
N	CH120SG9390	9390W	5590W	4080W	3290W
O	CH120SG11260	11260W	6700W	4890W	3940W
P	CH120SG13140	13140W	7820W	5710W	4600W
Q	CH120SG18780	18780W	11180W	8160W	6580W
R	CH120SG22520	22520W	13400W	9780W	7880W

All capacities are in watts to 91% of nominal voltage. Note: For other voltages and capacities contact your sales representative.

## FEATURES

- One set of dry contacts for remote fault sensings
- Remote alarm panel
- Drip shield (2.5" overhang on console)
- Brownout

## CABINET DIMENSIONS

SERIES	DIMENSIONS H X W X D
CH24SG820-3755	25" X 29" X 14"
CH36SG1230-3375	
CH36SG3940	38" X 38" X 18"
CH120SG4120	
CH120SG5660-11260	38" X 38" X 28"
CH120SG13140-22520	56" X 38" X 28"

Electronics and batteries are in the same cabinet.

## ORDERING INFORMATION

SYSTEM DESIGNATION	D.C. OUTPUT VOLTAGE	BATTERY TYPE	CAPACITY IN WATTS	OPERATING TIME	A.C. INPUT VOLTAGE (1PH)	TRANSFER OPTIONS	DISTRIBUTION OPTIONS	OPTIONS
CH	24 = 24VDC 36 = 36VDC 120 = 120VDC	SG= sealed Lead-Calcium	_____*	30 = 30 min 60 = 60 min 90 = 90 min 120 = 120 min	120 = 120VAC 208 = 208VAC 240 = 240VAC 277 = 277VAC 347 = 347VAC 600 = 600VAC	CP= normally off load TS= normally on load CP/TS= normally on and off load*	OPF= fuse panel* OFA= fuse panel with alarm CBO= circuit breaker panel* OCA= circuit breaker panel with breaker trip alarm	TD= Time delay (15 minutes)* 3PH= 3 phase sensing 12HR= 12 hour recharge CYC= Battery exerciser BCB= Battery circuit breaker ZSC= Common zone sensing**
			* Select from Battery Capacity chart in folder			* Specify Watts for each type of load.	*Specify number of circuits	* Specify time. ** Specify No. of zones.







# OPTIONS & ACCESSORIES

# TABLE OF CONTENTS

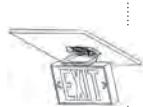
						
<b>LED RETROFIT KITS</b>	<b>LED BULB SERIES</b>	<b>48 &amp; FPS SERIES</b>	<b>EZ2 CANOPY</b>	<b>PENDANT KIT</b>	<b>WIRE GUARDS</b>	<b>NEXUS</b>
P. 184-185	P. 186	P. 187	P. 188	P. 189	P. 190-191	P. 192-193



# LED Retrofit Kits

Project/Location: \_\_\_\_\_

Contractor: \_\_\_\_\_

Date: \_\_\_\_\_

Prepared by: \_\_\_\_\_

## Convert high-consumption incandescent and fluorescent lamps to energy-efficient LED lamps

Converting existing Exit Signage from incandescent or fluorescent lamps to LED (light emitting diodes) lamps drastically reduces operating and maintenance costs for building owners and property managers. As part of energy-efficiency programs, some Canadian electric utilities are also actively promoting conversion to LED with incentive and rebate programs for installers and building owners/managers.

### FEATURES

**Emergi-Lite® offers four retrofit kit options; all based on the long-life ALINGAP LED technology:**

- SNAP II Series
- SNAP III Series
- SNAP I Series
- Bulb Series

### Benefits of using LED lamps in Exit Signs:

- Exceptional energy-efficiency – reduces energy consumption by up to 90%
- Extremely long life – 10 to 25 years
- Important reduction in maintenance and energy costs
- Average payback is less than two years (see page 6)
- Retrofit kits are easy to install
- Improved visibility and reliability: **ALINGAP** LED technology

### TYPICAL SPECIFICATION

Converting existing exit signage from incandescent or fluorescent lamps to LED (light emitting diodes) lamps drastically reduces operating and maintenance costs for building owners and property managers.

As part of energy efficiency programs, some Canadian electric utilities are also actively promoting conversion to LED with incentive and rebate programs for installers and building owners/managers.



### SNAP II SERIES

- Quick and easy to install
- Long-life, energy-efficient red **ALINGAP** LED technology
- Module features two independent circuits – one for AC input; one for DC input
- Universal AC input: 120/277/347VAC; universal two-wire DC input: 6 to 24VDC
- Power consumption of 1.1W per module
- 10 year limited warranty

### DIMENSIONS

Dimensions are approximate and subject to change.

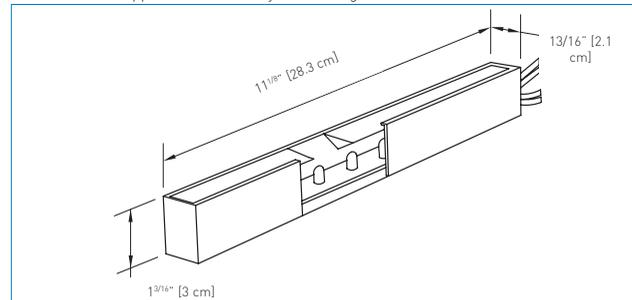

### POWER CONSUMPTION

MODEL	AC SPECS		DC SPECS	
SNAP II	120/277/347VAC	1.1W	6 to 24VDC	1.3W

### ORDERING INFORMATION

SERIES	VOLTAGE
SNAP II= hardwire retrofit kit 11.0" [28cm] long	-UN= 120/277/347VAC, 6/12/24VDC -U36= 120/277/347VAC, 36VDC
SNAP IIB= hardwire retrofit kit 9.5" [24cm] long*	-U48= 120/277/347VAC, 48VDC -U120= 120/347VAC, 120VDC -120V-1H2= 120VAC, 120VDC, 2 wires

\*Available in UN voltage only.

EXAMPLE: SNAPII-UN

Project/Location:

Contractor:

Date:

Prepared by:

# LED Retrofit Kits



New Design:  
0.65W; 60% off power consumption.

## SNAP III SERIES

- Easiest to install in its class
- Compact size makes it ideal for virtually all Exit Signs
- Can be retrofitted directly on fluorescent ballast
- Long-life, energy-efficient red ALINGAP LED technology
- Available with AC adaptor for all types of lamp sockets
- 10 year limited warranty

## DIMENSIONS

Dimensions are approximate and subject to change.

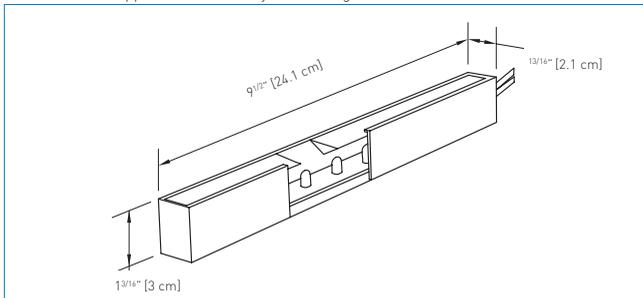

## POWER CONSUMPTION

MODEL	AC SPECS	DC SPECS
SNAP III	120VAC; 86VAC step down from 347VAC	0.65W N/A N/A

## ORDERING INFORMATION

SERIES	BASE
SNAP III= for standard applications	-C= candelabra -I= intermediate -M= medium -B= bayonet -F= G23 compact fluorescent -UN= complete set of bases (excludes "F" base) -H= 120VAC (hardwire) -2H= 277VAC (hardwire) -3H= 347VAC (hardwire)

EXAMPLE: SNAPIII-C



## SNAP I SERIES

- Easiest to install in its class
- Compact size makes it ideal for virtually all Exit Signs
- Can be retrofitted directly on fluorescent ballast
- Suitable for all AC line applications including Exit Signs equipped with in-line diodes
- Long-life, energy-efficient ALINGAP LED technology

## DIMENSIONS

Dimensions are approximate and subject to change.

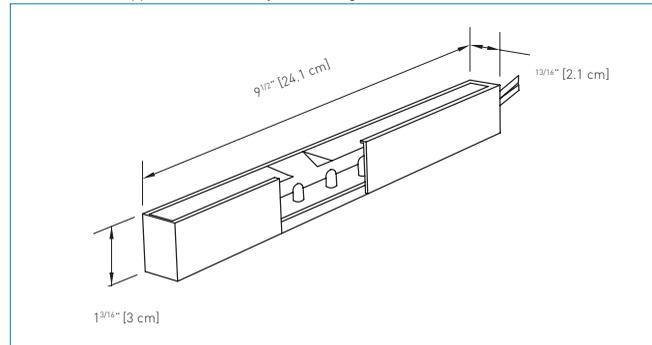

## POWER CONSUMPTION

MODEL	AC SPECS	DC SPECS
SNAP I	120VAC; 120VAC with in-line diodes	2.8W N/A N/A

## ORDERING INFORMATION

SERIES	BASE
SNAP I = with or without in-line diodes	-C= candelabra -I= intermediate -M= medium -B= bayonet -F= G23 compact fluorescent -UN= complete set of bases (excludes "F" base) -H= 120VAC (hardwire) -2H= 277VAC (hardwire) -3H= 347VAC (hardwire)

EXAMPLE: SNAP I-C



# LED Retrofit Kits

Project/Location:	_____
Contractor:	_____
Date:	_____
Prepared by:	_____



## BULB SERIES

- Quick and easy to install
- Available with a wide range of lamp bases for quick lamp to lamp replacement
- Long-life, energy-efficient **ALINGAP** LED technology
- 120VAC or 120VAC with in-line diode

## DIMENSIONS

Dimensions are approximate and subject to change.

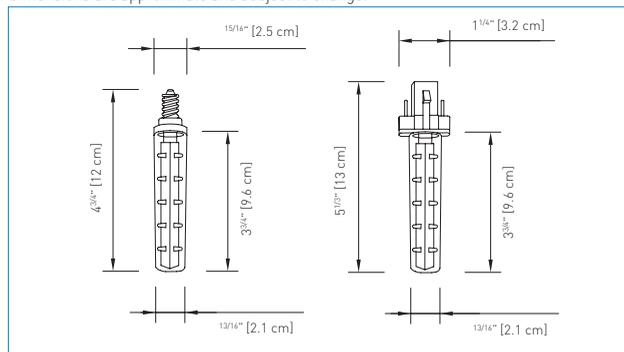

## POWER CONSUMPTION

MODEL	AC SPECS		DC SPECS	
BULB I	120VAC	0.90W	N/A	N/A
BULB II	120VAC	2.6W	120VDC	2.6W

## ORDERING INFORMATION

SERIES	BASE
<b>BULBI/HB</b> = standard version <b>BULBII/HB</b> = with or without in-line diodes (2.5W), high brightness	<b>C</b> = candelabra <b>I</b> = intermediate <b>M</b> = medium <b>B</b> = bayonet <b>F</b> = G23 compact fluorescent

EXAMPLE: BULBI-C

## TYPICAL SPECIFICATIONS

The following is an example of the savings you can generate by simply installing an LED retrofit kit in an existing incandescent Exit Sign.

The Retrofit Kit Cost:	\$70.00
Installation cost (per unit) for a retrofit kit (Labour):	\$5.00
Wattage rating per incandescent lamp in existing fixture:	15W
Number of incandescent lamps per fixture:	2
Wattage rating of Emergi-Lite LMRUNIV retrofit kit:	1.7W
My existing incandescent exit lamps last for:	4 Months
My replacement labour cost:	\$25.00/Hour
Estimated lamp replacement time per exit:	20 Minutes
Current material cost for each Exit Sign lamp:	\$1.00/Lamp
My current energy cost:	\$0.060/\$ Per kWh
<b>THE PAYBACK FOR YOUR INSTALLATION IS:</b>	1.06 Years
<b>THE ANNUAL RETURN ON INVESTMENT IS:</b>	94.50 %
<b>ANNUAL SAVINGS:</b>	\$70.87

For more information, please consult your sales representative.

Project/Location:

Contractor:

Date:

Prepared by:

# 48 Series & FPS Series

## Fluorescent Inverters



### FEATURES

- All FPS Series are fully load tested prior to shipment
- Inverter is 100% solid state, short and open circuit proof
- Polarized DC input (48 Series only)
- 120VAC 60Hz input is standard, 277 and 347VAC available as options
- 25%, 50% or 80% lamp lumen output
- Mounts directly in ballast channel, remote or optional T-Bar fixture
- CSA listed



### TYPICAL SPECIFICATIONS

**48 Series:** The electrical contractor shall supply and install **Emergi-Lite® 48 Series** remote fluorescent inverter ballasts for each fixture as shown on plans. The inverter shall operate on \_\_\_\_\_ VDC input for \_\_\_\_\_ minutes during a power failure. The fluorescent lamp shall be maintained at \_\_\_\_\_ % lumen output for one lamp only. The inverter is to be connected to the remote battery unit as shown on plans (battery unit to be selected according to voltage/wattage and duration required). The inverter shall be capable of illuminating the fluorescent lamp even when it is burned out under normal AC operation.

**FPS Series:** The electrical contractor shall supply and install **Emergi-Lite® FPS Series** fluorescent inverters for each fixture as shown on plans. The **FPS Series** inverter shall operate for \_\_\_\_\_ minutes during a power failure. The fluorescent lamp shall be maintained at \_\_\_\_\_ % of nominal lumen output. The **FPS Series** inverter shall be capable of illuminating the fluorescent lamp even when it is out under normal AC operations.

### DIMENSIONS

Dimensions are approximate and subject to change.

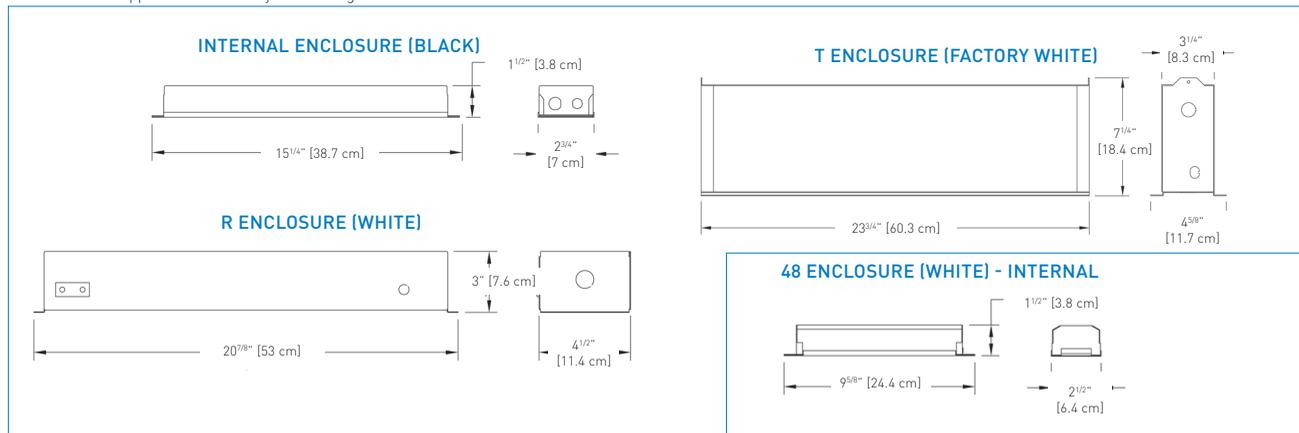

### ORDERING INFORMATION 48 SERIES

48 SERIES	LUMENS / (%) FOR 48" TUBE	VOLTAGE
4806= 6V	25= 25% (800 lumens)	Blank= 120VAC -2= 277VAC -3= 347VAC
4812= 12V	Lumen outputs based on averages.	
4824= 24V	60= 50% (1600 lumens)	
4832= 32V	24"/20W=1260 48"/40W=3200	
4848= 48V	96"/75W=6300	
48120= 120V	100= 80% (2560 lumens) Inverters will operate T12, T8, or "U" type lamps.	

EXAMPLE: 4812-25-3

### D.C. POWER CONSUMPTION

SERIES	OUTPUT %	LUMENS	W
FPS-800	25	800	10
FPS-1600	50	1600	20
FPS-3200	80	2560	32

### ORDERING INFORMATION FPS SERIES

SERIES	LUMENS / (%) FOR 48" TUBE	MIN. RUNTIME	HOUSING	AC VOLTAGE
FPS	25= 25% (800 lumens) Lumen outputs based on averages. 60= 50% (1600 lumens) 24"/20W=1260 48"/40W=3200 96"/75W=6300 100= 80% (2560 lumens) Inverters will operate T12, T8, or "U" type lamps.	30= 30 minutes 60= 60 minutes 90= 90 minutes 120= 120 minutes*	Blank= internal* R= remote mounting enclosure T= T-Bar	Blank= 120VAC -2= 277VAC -3= 347VAC
		*FPS100 in T-Bar cabinet only.	*Not available for FPS100.	

EXAMPLE: FPS60/30

# EZ2™ Canopy

Quick and Easy Installation

Project/Location: \_\_\_\_\_

Contractor: \_\_\_\_\_

Date: \_\_\_\_\_

Prepared by: \_\_\_\_\_

## DIMENSIONS

Dimensions are approximate and subject to change.

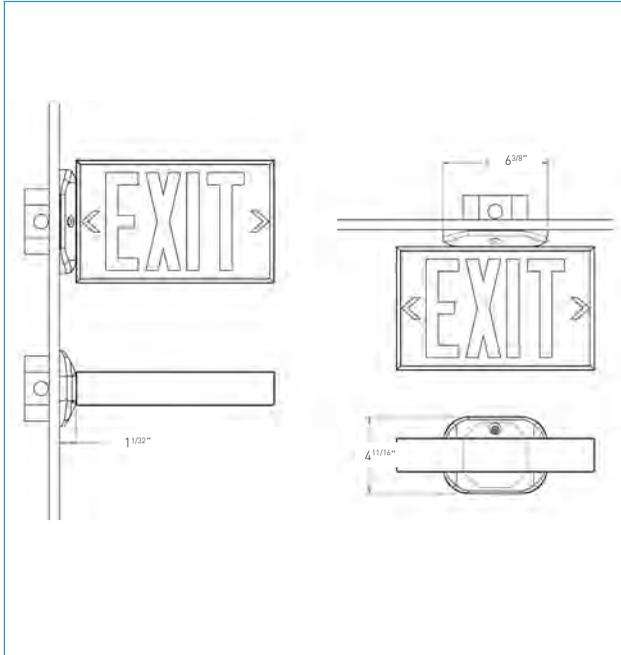

The **EZ2™ Canopy** allows the installer to make all of the electrical connections using both hands without having to juggle with the Exit Sign, making it our most contractor friendly product feature to date. Simply attach the backplate to the junction box, clip the canopy on the Exit Sign, hang the canopy on the back plate, make your connections using both hands, slide the unit in place, one screw and the job is done!

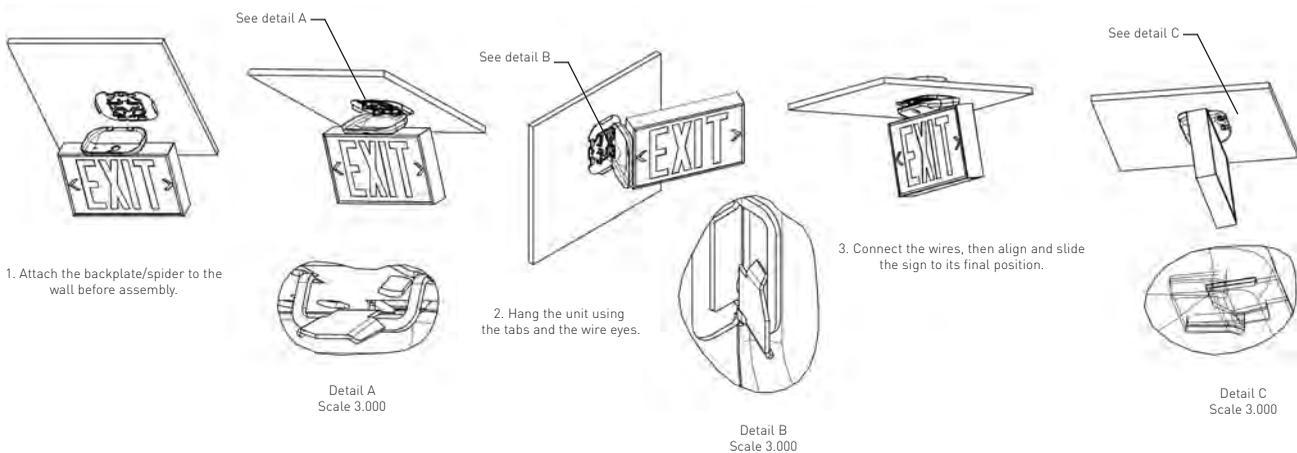

Project/Location:

Contractor:

Date:

Prepared by:

# Pendant Kit



## DIMENSIONS

Dimensions are approximate and subject to change.

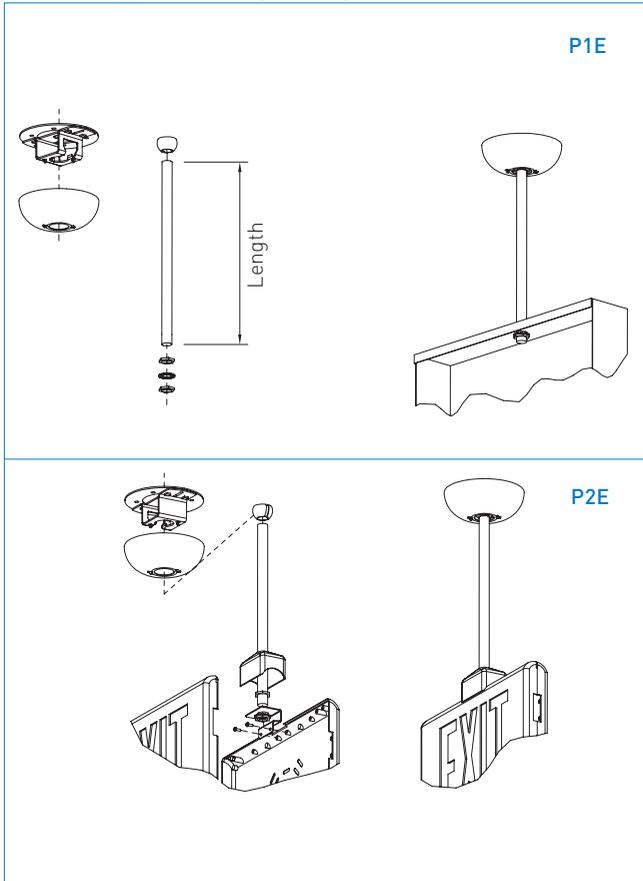

## TYPICAL SPECIFICATIONS

Offered in a variety of colours and lengths, **Emergi-Lite®** Pendant Kits are designed to facilitate the installation of Exit Signs at regular mounting heights.

Compatible with both horizontal and sloped ceilings, these Pendant Kits are truly universal and will adapt to any application.

Please consult your sales representative.

## ORDERING INFORMATION

SERIES	LENGTH (IN)	COLOUR
P1E*	6 12 18 24	W= white B= black SG= silver grey
P2E*	6 12 18 24	W= white B= black SG= silver grey
P23E* Edge-Lit	6 12 18 24	W= white B= black SG= silver grey
P4E* New Premier™ Plastic Exit	6 12 18 24	W= white B= black

\*Other lengths available on demand. Consult your sales representative.

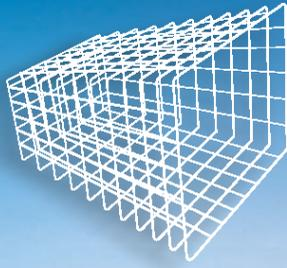

# Wire Guards

Project/Location:	_____
Contractor:	_____
Date:	_____
Prepared by:	_____

## EXIT SIGNS

PART #	MOUNTING	SIGNS		DIMENSIONS		
				W	H	D
460.0027-E	End Mount	LPEX100 LPEX50 LPEX600-N Series - Nema-4X Exit EX160 LPEX300	EX10 EN SR160 ES	10 1/2" (26.7 cm)	6" (15.2 cm)	16" (40.6 cm)
460.0028-E	Ceiling Mount	LPEX100 LPEX50 LPEX600 - Nema-4X EX160	LPEX300 EX10 EN SR160 ES	14 1/2" (36.8 cm)	6 1/4" (15.9 cm)	10 1/2" (26.5 cm)
460.0034-E	Wall Mount	12ESL-SR Sortie WP36	12ESL-EX C8SRPK-P	28 1/8" (71.5 cm)	21 1/8" (53.7 cm)	10" (25.4 cm)
460.0048-E	End Mount	LPSR100 C8SR50	LPSR300 C8SR10	10 1/2" (26.7 cm)	6" (15.2 cm)	21" (53.3 cm)
460.0057-E	Wall Mount	LPSR100 C8SR50	LPSR300 C8SR10	20 3/4" (52.7 cm)	10" (25.4 cm)	4" (10.2cm)
460.0058-E	Ceiling Mount	LPSR100 C8SR50	LPSR300 C8SR10	21 3/4" (55.2 cm)	5 1/2" (14 cm)	10 1/2" (26.7cm)
460.0059-E	Wall Mount	C8ES300 bilingual C8SE10	C8ES70 bilingual C8ES10	31" (86.4 cm)	10" (25.4 cm)	4 1/2" (14 cm)
460.0060-E	End Mount	LPEX600-N - Nema-4X Combo	EX10-P	20" (50.8 cm)	12" (30.5 cm)	15" (38.1 cm)
460.0060-E	Wall Mount	EN LPEX600-N Combo	EX10-P	20" (50.8 cm)	12" (30.5 cm)	15" (38.1 cm)
460.0078-E	Wall Mount	C8SR50-P Combo LPEX600-N - Nema-4X Combo	EX10-P ENC Premier™ Combo	18" (45.7 cm)	18" (45.7 cm)	7" (17.8 cm)
460.0079-E	Wall Mount	LPEX100 LPEX50 LPEX600 - Nema-4X EX160 LPEX300	EX10 Premier™ Exit EN ES SR160	14 1/4" (36.2 cm)	9 7/8" (25.0 cm)	4 5/8" (11.7 cm)
460.0080-E	Wall Mount	EXHZ combo (class1 Div2)	LPEXHZ Exit	15 1/4" (38.7 cm)	14 1/8" (35.9 cm)	6 1/2" (16.5 cm)
460.0081-E	Wall Mount	12ESL-EX, EAC, EX10-P, SR, ESC		20" (50.8 cm)	17 1/8" (43.6 cm)	8 1/2" (21.6 cm)
460.0091-E	Wall Mount	EX10-P		15" (38.1 cm)	10 1/2" (26.7 cm)	1" (2.5 cm)
460.0092-E	Ceiling Mount	C8SR10 C8ES300 Bilingual C8ES70	EX10-P C8ES70	31" (53.3 cm)	4.5" (11.4 cm)	10" (25.4 cm)
460.0103-E	Wall Mount	C8SRPK-P	C8E/S35R	25" (63.5 cm)	15" (38.1 cm)	6" (15.2 cm)
460.0104-E	End Mount	C8SR10		25" (63.5 cm)	10" (25.4 cm)	20" (50.8 cm)

Project/Location:

Contractor:

Date:

Prepared by:

# Wire Guards & Mounting Shelves

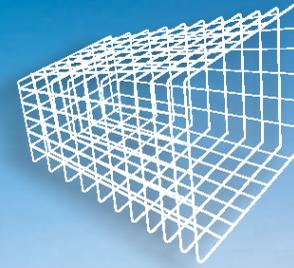

## BATTERY UNITS

PART	MOUNTING	COMMERCIAL, DECO UNIT	DIMENSIONS		
			W	H	D
460.0078-E	Wall Mount	"A" Cabinet-6V, 12V, 24V-Max. 144W	8" (45.7 cm)	8" (45.7 cm)	7" (17.8 cm)
460.0081-E	Wall Mount	"B" Cabinet-6V-180W 12V-200 to 360W 24V-200 to 288W	20" (50.8 cm)	17 1/8" (43.6 cm)	8 1/2" (21.6 cm)
460.0034-E 460.0097-E	Wall Mount	"C" Cabinet-12V-650watts 24V-350 to 720W Q-BIC	28 1/8" (71.5 cm)	21 1/8" (53.7 cm)	10" (25.4 cm)
			31" (53.3 cm)	70" (17.8 cm)	6" (15.2 cm)

## SMALL, 6V

460.0080-E	Wall Mount	6V, 12V - 18 to 72W	15 1/4" (38.7 cm)	14 1/8" (35.9 cm)	6 1/2" (16.5 cm)
------------	------------	---------------------	----------------------	----------------------	---------------------

## INDUSTRIAL

460.0082-E	Wall Mount	Small Cabinet	12" (30.5 cm)	9" (3.5 cm)	9" (3.5 cm)
460.0081-E		Medium and Large Cabinet	20" (50.8 cm)	17 1/8" (43.6 cm)	8 1/2" (21.6 cm)

## REMOTE HEADS

PART #	REMOTE HEADS	DIMENSIONS		
		W	H	D
460.0029-E	EF9, EF9Q, EF9M, EF11, EF25	8 1/4" (21.5 cm)	6 1/4" (15.9 cm)	6 3/4" (17.2 cm)
460.0031-E	EF26D, EF18T, EF11D	25 1/4" (64.1 cm)	8 1/2" (21.5 cm)	8 1/2" (21.5 cm)
460.0032-E	EF26DS, EF150	9 1/2" (24.1 cm)	9 1/2" (24.1 cm)	6 1/8" (15.6 cm)
460.0033-E	EF15	9 1/2" (24.1 cm)	9 1/2" (24.1 cm)	4" (10.2 cm)
460.0035-E	EF18, EF11, EF30, EF26, EF39, EF40	8 1/4" (21.5 cm)	6 1/4" (15.9 cm)	8 1/2" (21.5 cm)
460.0082-E	EF18D, EF11D, EF30D, Literay™, Lux-Ray™, Retract-a-Lite™	12" (30.5 cm)	9" (22.9 cm)	9" (22.9 cm)
460.0100-E	Provider™	14" (35.6 cm)	5.8" (14.7 cm)	5.6" (14.2 cm)

## MOUNTING SHELVES

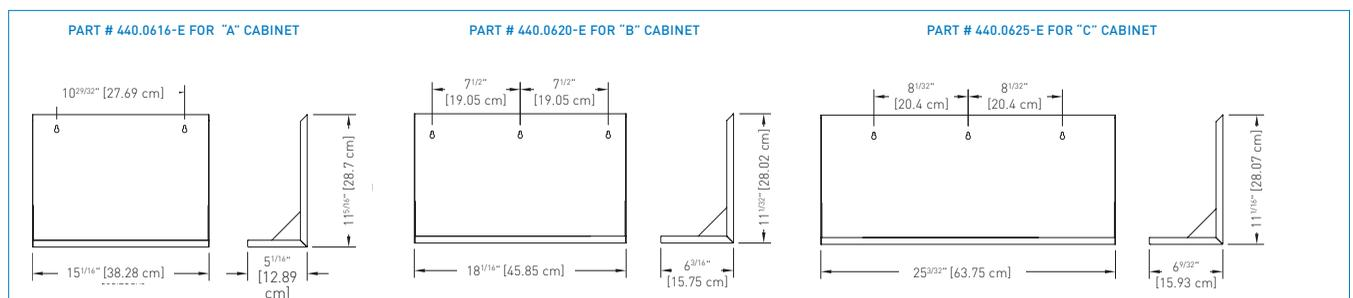

# NEXUS® EMERGENCY LIGHTING MANAGEMENT SYSTEM

## ARE YOU PREPARED FOR A SAFETY INSPECTION?

Building & Life Safety Codes oblige building owners/managers to ensure the safe evacuation of a building in the event of an emergency. In the interest of public safety, building owners/managers must meet the outlined requirements for exit signs and emergency lighting equipment, including the following:

- Conduct a discharge test every month.
- Conduct functional tests annually.
- Keep a log book of maintenance information.

Complying with these requirements can be labour intensive and costly, especially in large buildings where testing every emergency light requires many man-hours.

Disrupting the power supply during lengthy inspections can also put public safety at risk.

## MANAGE TESTING WITH NEXUS® TO SAVE TIME AND COSTS

Nexus® is a real-time monitoring system that manages the status of your entire Emergency Lighting and Exit Sign system from a central control unit. Nexus® runs diagnostics, performs required monthly and annual functional tests, generates maintenance logs and runs compliance reports.

Available in wired or wireless (RF) versions, Nexus® installations often pay for themselves in less than two years. In addition to operational savings, Nexus® helps increase system reliability and performance and reduces the risk of failed inspections. One building or a group of properties under the same management can be monitored with Nexus®.



## MAXIMIZE SYSTEM AVAILABILITY

By allowing maintenance personnel to easily maintain and monitor the emergency lighting system without having to manually check each unit, Nexus® reduces the hours required to disrupt the power supply for inspections. With Nexus®, monthly tests and reports on the status of all emergency lights and exit signs can be done individually, in groups, or together.

Advantages of the Nexus® system include saving labor; maximizing system availability by testing units in groups and stages rather than setting all units in recovery mode; and the convenience of self-monitoring. Nexus® indicates the location of a faulty unit and reports it instantly without requiring a manual search.

## UPDATE STATUS INSTANTLY

Nexus® passes messages both to and from the emergency units to instruct the units to perform all mandatory testing by communicating between the emergency units and a centrally located controller.

Nexus® is a proven system supported by a 5-year warranty, and can contribute to LEED certification and support green building initiatives.



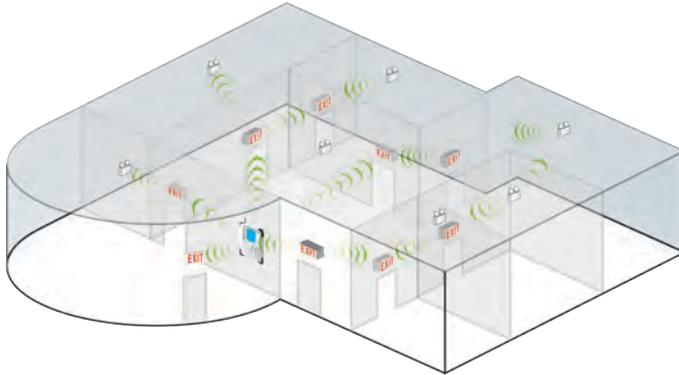

### SMALL SYSTEM EXAMPLE

In a system of fewer than 100 units it is most likely that the only hardware required, other than the emergency units themselves, is a controller. All communication would occur wirelessly and installation would not vary greatly from a non-monitored system. Once the units are in place, the system will establish the mesh network. The building itself could be quite large as each unit only needs to be able to communicate with its close neighbours and does not need to communicate directly with the controller.

### LARGE SYSTEM EXAMPLE

The Nexus® RF system has been designed to be extremely flexible and provides for a range of system options. Each large site will need to be assessed for the best system solution with the assistance of Thomas & Betts technical staff.

The basic Nexus® RF system is designed to run on an Ethernet network which is present in most modern buildings; however, through a range of interface cards the backbone of the network could be WLAN.

As with the small system example, site performance will be optimized through the careful selection and placement of Area Controller Routers and the Area Controller to form efficient clusters. Building layout and materials will also play some role in determining the best solution to deliver a highly effective means of testing and maintenance requirements.

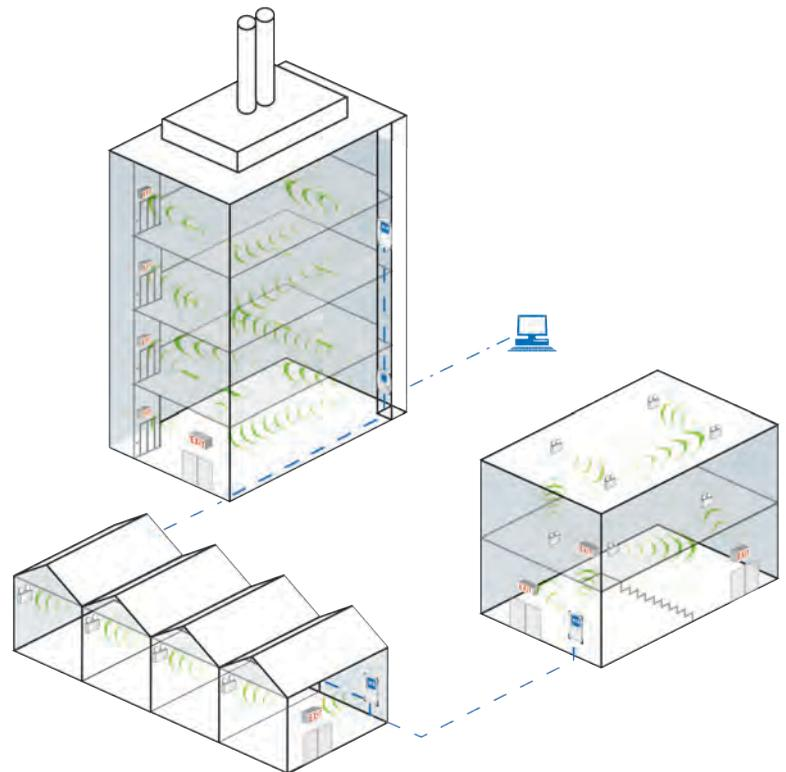



TECHNICAL  
INFO

ELECTRICAL  
CODE

BUILDING  
CODE

WARRANTY



# TECHNICAL INFORMATION

# TABLE OF CONTENTS



<b>WIRE SIZE GUIDE</b>	<b>BATTERY UNIT CAPACITY CHART</b>	<b>ELECTRICAL CODE</b>	<b>BUILDING CODE</b>	<b>FIRE &amp; GENERATOR ROOM</b>	<b>LIMITED WARRANTY</b>	<b>PRODUCT INDEX</b>
P. 198	P. 199	P. 200-201	P. 202-205	P. 200	P. 207	P. 208

# Wire Size Guide

When remote fixtures and exit signs are connected to emergency lighting units of less than 50 volts, circuit runs must be sufficient size to maintain a proper operating voltage to all lamps. The maximum allowable voltage drop should not exceed 5%. Proper wire size can be selected from the following table or by use of the following formula:

$$CM = \frac{22 \times W \times L}{.05 \times E^2}$$

**CM**= Wire size in circular mills

**W**= Emergency load in watts

**L**= Length of circuit in feet

**E**= Line Voltage

**22**= Constant

**.05**= Factor for max. allowable voltage drop

## LENGTH OF WIRE RUN (in feet)

	WIRE SIZE	WATTS													
		13	18	25	30	35	50	60	75	100	150	200	250	300	400
6V	12	41	30	21	18	15	11	9	8	6	4	—	—	—	—
	10	65	47	32	28	24	17	14	11	9	6	—	—	—	—
	8	110	75	54	45	39	27	22	18	14	9	7	—	—	—
	6	165	120	86	71	62	43	36	29	22	15	11	9	—	—
12V	12	165	110	85	71	61	42	35	29	21	14	10	8	—	—
	10	260	190	136	112	97	68	52	45	34	23	17	14	11	—
	8	415	300	215	180	154	108	90	72	54	36	27	21	18	—
	6	660	475	340	285	245	170	140	114	86	57	43	34	28	—
4	1050	760	540	455	390	275	225	182	137	91	68	55	45	—	
24V	12	660	440	340	284	244	168	140	116	84	56	40	32	26	21
	10	1040	760	544	448	388	272	208	180	136	92	68	52	44	34
	8	1668	1200	860	720	616	432	360	288	216	144	108	84	72	54
	6	2640	1900	1360	1140	980	680	560	456	344	228	172	136	112	85
4	4200	3040	2160	1810	1560	1100	900	728	548	364	272	220	180	100	
32V	12	1160	840	600	500	435	300	250	200	150	100	75	60	50	42
	10	—	1340	960	800	690	480	400	320	240	160	120	96	80	63
	8	—	—	1540	1280	1110	770	640	510	385	255	192	154	128	100
	6	—	—	—	—	1740	1220	1020	815	610	405	305	240	200	163
4	—	—	—	—	—	—	1620	1300	970	650	485	390	325	260	
48V	12	—	1899	1367	1139	949	680	—	455	341	227	170	136	113	68
	10	—	—	—	1811	1509	1085	—	724	543	362	271	217	181	108
	8	—	—	—	—	—	1729	—	1152	864	576	432	345	288	172
	6	—	—	—	—	—	—	—	1832	1374	916	687	549	458	274
120V	12	14964	—	7792	—	—	3896	—	—	1945	1300	977	720	650	608
	10	23787	—	12367	—	—	6193	—	—	3093	2067	1553	1238	1033	966
	8	37810	—	19705	—	—	9852	—	—	4820	3289	2471	1970	1644	1538
	6	60159	—	31327	—	—	15663	—	—	7822	5229	3929	3132	2614	2445

# Battery Unit Capacity Chart

## BATTERY UNIT

	WATTAGE CAPACITY				
	30MIN	1H00	1H30	2H00	4H00
6V - 36W	36	21	15	12	6
6V - 72W	72	42	30	24	12
6V - 108W	108	63	45	36	18
6V - 180W	180	105	75	60	30
12V - 36W	36	21	15	12	6
12V - 72W	72	42	30	24	12
12V - 100W	100	58	42	33	17
12V - 144W	144	84	60	48	24
12V - 200W	200	117	83	67	33
12V - 250W	250	144	100	83	42
12V - 288W	288	168	120	96	48
12V - 360W	360	210	150	120	60
24V - 144W	144	84	60	48	24
24V - 200W	200	117	83	67	33
24V - 288W	288	168	120	96	48
24V - 350W	350	200	144	120	60
24V - 432W	432	250	180	144	72
24V - 550W	550	320	230	180	90



ESL



ESLT



ESLPK



RETRACT-A-LITE



DEL

# Electrical Code

Extracts from the Canadian  
Electrical Code 2010

## SECTION 46 — EMERGENCY POWER SUPPLY, UNIT EQUIPMENT, EXIT SIGNS, AND LIFE SAFETY SYSTEMS

### 46-000 SCOPE (SEE APPENDIX B)

- 1 This Section applies to the installation, operation, and maintenance of
  - (a) emergency power supply and unit equipment intended to provide power to life safety systems; and
  - (b) emergency power supply and unit equipment intended to provide illumination of exit signs, in the event of failure of the normal supply, where the emergency power supply is required by the National Building Code of Canada.
- 2 This Section applies to the wiring between the emergency power supply and life safety systems that are required by the National Building Code of Canada to be provided with an emergency power supply
- 3 This Section applies to the wiring of exit signs
- 4 The requirements of this Section supplement or amend the general requirements of this Code

### 46-002 SPECIAL TERMINOLOGY (SEE APPENDIX B)

In this Section, the following definitions apply:

#### Emergency power supply

Emergency power, supplied by a generator, batteries, or a combination thereof, that is required by the National Building Code of Canada.

#### Life safety systems

Emergency lighting and fire alarm systems that are required to be provided with an emergency power supply from batteries, generators, or a combination thereof, and electrical equipment for building services such as fire pumps, elevators, smoke-venting fans, smoke control fans, and dampers that are required to be provided with an emergency power supply by an emergency generator in conformance with the National Building Code of Canada.

#### Unit equipment

Unit equipment for emergency lighting conforming to CSA C22.2 No. 141.

## GENERAL

### 46-100 CAPACITY

Emergency power supply and unit equipment shall have adequate capacity and rating to ensure the satisfactory operation of all connected equipment when the principal source of power fails.

### 46-102 INSTRUCTIONS

- 1 Complete instructions for the operation and care of an emergency power supply or unit equipment that shall specify testing at least once every month to ensure security of operation shall be posted on the premises in a frame under glass.
- 2 The form of instructions and their locations shall be in compliance with the National Building Code of Canada.

### 46-104 MAINTENANCE

Where batteries are used as a source of the emergency power supply, the batteries shall be kept

- (a) in proper condition; and
- (b) fully charged at all times

### 46-106 ARRANGEMENT OF LAMPS

- 1 Emergency lights shall be arranged so that the failure of any one lamp will not leave in total darkness the area normally illuminated by it.
- 2 No appliance or lamp, other than those required for emergency purposes, shall be supplied by the emergency circuits.

### 46-108 WIRING METHOD (SEE APPENDICES B AND G)

- 1 Except as permitted by Subrule (3), Rule 46-304(3), and Rule 46-400(2), the following conductors shall be installed in accordance with Subrule (2):
  - (a) conductors required for operation of life safety systems and installed between an emergency power supply and life safety systems;
  - (b) conductors between an emergency power supply and exit signs; and
  - (c) conductors between unit equipment and remote lamps.
- 2 Conductors described in Subrule (1) shall be
  - (a) installed in metal raceway of the totally enclosed type;
  - (b) incorporated in a cable having a metal armour or sheath;
  - (c) installed in rigid non-metallic conduit; or
  - (d) installed in electrical non-metallic tubing where embedded in at least 50 mm of masonry or poured concrete.
- 3 Not with standing Subrule (2), conductors installed in buildings of combustible construction in accordance with Rules 12-506 to 12-520 shall be permitted to be
  - (a) run as a non-metallic-sheathed cable; or
  - (b) installed in a totally enclosed non-metallic raceway.
- 4 Conductors installed in accordance with Subrule (1) shall be kept entirely independent of all other conductors and equipment and shall not enter a luminaire, raceway, box, cabinet, or unit equipment occupied by other conductors except where necessary
  - (a) in transfer switches; and
  - (b) in exit signs and emergency lights supplied from two sources.
- 5 Conductors between an emergency power supply and any electrical equipment that is not defined as a "life safety system" in accordance with this Section shall not enter a luminaire, raceway, box, or cabinet occupied by conductors installed as described in Subrule (1), except where necessary in busways, splitters, and other similar enclosures provided for connection to the overcurrent device for an emergency power supply described in Rule 46-208(1).

## EMERGENCY POWER SUPPLY

### 46-200 EMERGENCY POWER SUPPLY (SEE APPENDIX B)

Rules 46-202 to 46-212 apply only to emergency power supply from central standby power sources.

### 46-202 TYPES OF EMERGENCY POWER SUPPLY (SEE APPENDIX G)

- 1 The emergency power supply shall be a standby supply consisting of
  - (a) a storage battery of the rechargeable type having sufficient capacity to supply and maintain at not less than 91% of full voltage the total load of the emergency circuits for the time period required by the National Building Code of Canada, but in no case less than 30 min, and equipped with a charging means to maintain the battery in a charged condition automatically; or
  - (b) a generator.
- 2 Automobile batteries and lead batteries not of the enclosed glass-jar type are not considered suitable under Subrule (1) and shall be used only where a deviation has been allowed in accordance with Rule 2-030.

# Electrical Code

Extracts from the Canadian  
Electrical Code 2010

- 3 Where a generator is used, it shall be
  - (a) of sufficient capacity to carry the load;
  - (b) arranged to start automatically without failure and without undue delay upon the failure of the normal power supply to any transfer switch connected to this generator; and
  - (c) in conformance with CSA C282.

## 46-204 PROTECTION OF ELECTRICAL CONDUCTORS (SEE APPENDICES B AND G)

All power, control, and communication conductors between an emergency generator as described in Rule 46-202(3), and electrical equipment required to be installed as a part of the emergency power supply and located outside the generator room shall be protected against fire exposure to provide continued operation in compliance with the National Building Code of Canada.

## 46-206 CONTROL

- 1 An emergency power supply shall be controlled by automatic transfer equipment that actuates the emergency power supply upon failure of the normal current supply and that is accessible only to authorized persons.
- 2 An automatic light-actuated device, approved for the purpose, shall be permitted to be used to control separately the lights located in an area that is adequately illuminated during daylight hours without the need for artificial lighting.

## 46-208 OVERCURRENT PROTECTION

- 1 The overcurrent device for an emergency power supply shall be coordinated with the overcurrent devices of feeders and branch circuits supplying life safety systems and other electrical equipment connected to the emergency power supply in order to provide selective operation of the branch circuit overcurrent device when a fault occurs in that branch circuit.
- 2 The branch circuit overcurrent devices shall be accessible only to authorized persons.

## 46-210 AUDIBLE AND VISUAL TROUBLE-SIGNAL DEVICES

- 1 Every emergency power supply shall be equipped with audible and visual trouble-signal devices that warn of derangement of the current source or sources and that indicate when exit signs or life safety systems are supplied from the emergency power supply.
- 2 Audible trouble signals shall be permitted to be wired so that (a) they can be silenced, but a red warning or trouble light shall continue to provide the protective function; and
  - (b) when the system is restored to normal, the audible signal will
    - (i) sound, indicating the need to restore the silencing switch to its normal position; or
    - (ii) reset automatically so as to provide sound for any subsequent operation of the emergency power supply.

## 46-212 REMOTE LAMPS

Lamps shall be permitted to be mounted at some distance from the current supply that feeds them, but the voltage drop in the wiring feeding such lamps shall not exceed 5% of the applied voltage.

## UNIT EQUIPMENT

### 46-300 UNIT EQUIPMENT (SEE APPENDIX B)

Rules 46-302 to 46-306 apply to individual unit equipment for emergency lighting only.

### 46-302 MOUNTING OF EQUIPMENT

Each unit equipment shall be mounted with the bottom of the enclosure not less than 2 m above the floor, wherever practicable.

## 46-304 SUPPLY CONNECTIONS

Each unit equipment shall be mounted with the bottom of the enclosure not less than 2 m above the floor, wherever practicable.

- 1 Receptacles to which unit equipment is to be connected shall be not less than 2.5 m above the floor, where practicable, and shall be not more than 1.5 m from the location of the unit equipment.
- 2 Unit equipment shall be permanently connected to the supply if
  - (a) the voltage rating exceeds 250 V; or
  - (b) the marked input rating exceeds 24 A.
- 3 Where the ratings in Subrule (2) are not exceeded, the unit equipment shall be permitted to be connected using the flexible cord and attachment plug supplied with the equipment.
- 4 Unit equipment shall be installed in such a manner that it will be automatically actuated upon failure of the power supply to the normal lighting in the area covered by that unit equipment.

## 46-306 REMOTE LAMPS (SEE APPENDIX B)

- 1 The size of circuit conductors to remote lamps shall be such that the voltage drop does not exceed 5% of the marked output voltage of the unit equipment, or such other voltage drop for which the performance of unit equipment is certified when connected to the specific remote lamp being installed.
- 2 Remote lamps shall be suitable for remote connection and shall be included in the list of lamps provided with the unit equipment.
- 3 The number of lamps connected to a single unit equipment shall not result in a load in excess of the watts output rating marked on the equipment for the emergency period required by the National Building Code of Canada, and the load shall be computed from the information in the list of lamps referred to in Subrule (2).

## EXIT SIGNS

### 46-400 EXIT SIGNS (SEE APPENDICES B AND G)

- 1 Where exit signs are connected to an electrical circuit, that circuit shall be used for no other purpose.
- 2 Notwithstanding Subrule (1), exit signs shall be permitted to be connected to a circuit supplying emergency lighting in the area where these exit signs are installed.
- 3 Exit signs in Subrules (1) and (2) shall be illuminated by an emergency power supply where emergency lighting is required by the National Building Code of Canada.

# Building Code

Extracts from the National Building  
Code of Canada 2010

## 3.2.6. ADDITIONAL REQUIREMENTS FOR HIGH BUILDINGS (SEE APPENDIX B.)

### 3.2.6.1. APPLICATION

- 1 This Subsection applies to a building
  - a) of Group A, D, E or F major occupancy classification that is more than
    - i) 36 m high, measured between grade and the floor level of the top storey, or
    - ii) 18 m high, measured between grade and the floor level of the top storey, and in which the cumulative or total occupant load on or above any storey above grade, other than the first storey, divided by 1.8 times the width in metres of all exit stairs at that storey, exceeds 300,
  - b) containing a Group B major occupancy in which the floor level of the highest storey of that major occupancy is more than 18 m above grade,
  - c) containing a floor area or part of a floor area located above the third storey designed or intended as a Group B, Division 2 or 3 occupancy, or
  - d) containing a Group C major occupancy whose floor level is more than 18 m above grade.

### 3.2.7.3. EMERGENCY LIGHTING

- 1 Emergency lighting shall be provided to an average level of illumination not less than 10 lx at floor or tread level in
  - a) exits
  - b) principal routes providing access to exit in open floor areas and in service rooms,
  - c) corridors used by the public,
  - d) corridors serving sleeping rooms in a treatment occupancy,
  - e) corridors serving sleeping rooms in a care occupancy, except corridors serving sleeping rooms within individual suites of care occupancy,
  - f) corridors serving classrooms,
  - g) underground walkways,
  - h) public corridors,
  - i) floor areas or parts thereof where the public may congregate
    - i) in Group A, Division 1 occupancies, or
    - ii) in Group A, Division 2 and 3 occupancies having an occupant load of 60 or more,
  - j) floor areas or parts thereof of daycare centres where persons are cared for, and
  - k) food preparation areas in commercial kitchens.
- 2 Emergency lighting to provide an average level of illumination of not less than 10 lx at floor or catwalk level shall be included in a service space referred to in Sentence 3.2.1.1.[8].
- 3 The minimum value of the illumination required by Sentences (1) and (2) shall be not less than 1 lx.
- 4 In addition to the requirements of Sentences (1) to (3), the installation of battery-operated emergency lighting in buildings or part thereof where treatment is provided shall conform to the appropriate requirements of CSA Z32, "Electrical Safety and Essential Electrical Systems in Health Care Facilities".

### 3.2.7.4. EMERGENCY POWER FOR LIGHTING

- 1 An emergency power supply shall be
  - a) provided to maintain the emergency lighting required by this Subsection from a power source such as batteries or generators that will continue to supply power in the event that the regular power supply to the building is interrupted, and
  - b) so designed and installed that upon failure of the regular power it will assume the electrical load automatically for a period of
    - i) 2 h for a building within the scope of Subsection 3.2.6.,
    - ii) 1 h for a building of Group B major occupancy classification that is not within the scope of Subsection 3.2.6., and
    - iii) 30 min for a building of any other occupancy. (See Appendix A.)
- 2 If self-contained emergency lighting units are used, they shall conform to CSA C22.2 No. 141, "Emergency Lighting Equipment."

### 3.2.7.5. EMERGENCY POWER SUPPLY INSTALLATION

- 1 Except as required by Articles 3.2.7.6. and 3.2.7.7., an emergency electrical power supply system shall be installed in conformance with CAN/CSA-C282, "Emergency Electrical Power Supply for Buildings." (See Sentence 3.2.7.8.(1) for emergency electrical power supply for voice communication systems).

## 3.4.5. EXIT SIGNS

### 3.4.5.1. EXIT SIGNS

- 1 Every exit door shall have an exit sign placed over or adjacent to it if the exit serves
  - a) a building more than 2 storeys in building height,
  - b) a building having an occupant load of more than 150, or
  - c) a room or floor area that has a fire escape as part of a required means of egress
- 2 Every exit sign shall
  - a) be visible on approach to the exit,
  - b) except as permitted in Sentence (3), consist of a green pictogram and a white or lightly tinted graphical symbol meeting the colour specifications referred to in ISO 3 864-1, "Graphical symbols – Safety colours and safety signs – Part 1: Design principles for safety signs in workplaces and public areas," and
  - c) conform to the dimensions indicated in ISO 7010, "Graphical symbols – Safety colours and safety signs – Safety signs used in workplaces and public areas," for the following symbols (see Appendix A):
    - i) E001 emergency exit left,
    - ii) E002 emergency exit right,
    - iii) E005 90-degree directional arrow, and
    - iv) E006 45-degree directional arrow
- 3 Internally illuminated exit signs shall be continuously illuminated and
  - a) where illumination of the sign is powered by an electrical circuit, be constructed in conformance with CSA C22.2 No. 141, "Emergency Lighting Equipment," or
  - b) where illumination of the sign is not powered by an electrical circuit, be constructed in conformance with CAN/ULC-S572, "Photoluminescent and Self-Luminous Signs and Path Marking Systems."
- 4 Externally illuminated exit signs shall be continuously illuminated and be constructed in conformance with CAN/ULC-S572, "Photoluminescent and Self-Luminous Signs and Path Marking Systems." (See Appendix A.)
- 5 The circuitry serving lighting for externally and internally illuminated exit signs shall
  - a) serve no equipment other than emergency equipment, and
  - b) be connected to an emergency power supply as described in Article 3.2.7.4.

# Building Code

## Extracts from the National Building Code of Canada 2010

- 6 Where no exit is visible from a public corridor, from a corridor used by the public in a Group A or B major occupancy, or from principal routes serving an open floor area having an occupant load of more than 150, an exit sign conforming to Clauses (2)(b) and (c) with an arrow or pointer indicating the direction of egress shall be provided.
- 7 Except for egress doorways described in Sentence 3.3.2.4.(4), an exit sign conforming to Sentences (2) to (5) shall be placed over or adjacent to every egress doorway from rooms with an occupant load of more than 60 in Group A, Division 1 occupancies, dance halls, licensed beverage establishments, and other similar occupancies that, when occupied, have lighting levels below that which would provide easy identification of the egress doorway.

### 3.4.5.2. SIGNS FOR STAIRS AND RAMPS AT EXIT LEVEL

- 1 In a building more than 2 storeys in building height, any part of an exit ramp or stairway that continues up or down past the lowest exit level shall have a posted sign clearly indicating that it does not lead to an exit.

## 9.9.11. SIGNS

### 9.9.11.1. APPLICATION

- 1 This Subsection applies to all exits except those serving not more than one dwelling unit or a house with a secondary suite.

### 9.9.11.2. VISIBILITY OF EXITS

- 1 Exits shall be located so as to be clearly visible or their locations shall be clearly indicated.

### 9.9.11.3. EXIT SIGNS

- 1 Every exit door shall have an exit sign placed over it or adjacent to it if the exit serves
  - a) a building that is 3 storeys in building height,
  - b) a building having an occupant load of more than 150, or
  - c) a room or floor area that has a fire escape as part of a required means of egress.
- 2 Every exit sign shall
  - a) be visible on approach to the exit,
  - b) except as permitted in Sentence (3), consist of a green pictogram and a white or lightly tinted graphical symbol meeting the colour specifications referred to in ISO 3864-1, "Graphical symbols – Safety colours and safety signs – Part 1: Design principles for safety signs in workplaces and public areas," and
  - c) conform to the dimensions indicated in ISO 7010, "Graphical symbols – Safety colours and safety signs – Safety signs used in workplaces and public areas," for the following symbols (see A-3.4.5.1.(2)(c) in Appendix A):
    - i) E001 emergency exit left,
    - ii) E002 emergency exit right,
    - iii) E005 90-degree directional arrow, and
    - iv) E006 45-degree directional arrow.
- 3 Internally illuminated exit signs shall be continuously illuminated and
  - a) where illumination of the sign is powered by an electrical circuit, be constructed in conformance with CSA C22.2 No. 141, "Emergency Lighting Equipment," or
  - b) where illumination of the sign is not powered by an electrical circuit, be constructed in conformance with CAN/ULC-S572, "Photoluminescent and Self-Luminous Signs and Path Marking Systems."
- 4 Externally illuminated exit signs shall be continuously illuminated and be constructed in conformance with CAN/ULC-S572, "Photoluminescent and Self-Luminous Signs and Path Marking Systems." (See A-3.4.5.1.(4) in Appendix A.)

- 5 The circuitry serving lighting for externally and internally illuminated exit signs shall
  - a) serve no equipment other than emergency equipment, and
  - b) be connected to an emergency power supply as described in Sentences 9.9.12.3.(2), (3) and (7).
- 6 Where no exit is visible from a public corridor, from a corridor used by the public, or from principal routes serving an open floor area having an occupant load of more than 150, an exit sign conforming to Clauses (2)(b) and (c) with an arrow or pointer indicating the direction of egress shall be provided

### 9.9.11.4. SIGNS FOR STAIRS AND RAMPS AT EXIT LEVEL

- 1 In buildings that are 3 storeys in building height, any part of an exit ramp or stairway that continues up or down past the lowest exit level shall be clearly marked to indicate that it does not lead to an exit, if the portion beyond the exit level may be mistaken as the direction of exit travel.

## 9.9.12. LIGHTING

### 9.9.11.4. SIGNS FOR STAIRS AND RAMPS AT EXIT LEVEL

- 1 This Subsection applies to the lighting of all means of egress except those within dwelling units or a house with a secondary suite.

### 9.9.12.2. REQUIRED LIGHTING IN EGRESS FACILITIES

- 1 Every exit, public corridor or corridor providing access to exit for the public shall be equipped to provide illumination to an average level of not less than 50 lx at floor or tread level and at all points such as angles and intersections at changes of level where there are stairs or ramps.
- 2 The minimum value of the illumination required by Sentence (1) shall be not less than 10 lx

### 9.9.12.3. EMERGENCY LIGHTING

- 1 Emergency lighting shall be provided in
  - a) exits,
  - b) principal routes providing access to exit in an open floor area,
  - c) corridors used by the public,
  - d) underground walkways, and
  - e) public corridors.
- 2 Emergency lighting required in Sentence (1) shall be provided from a source of energy separate from the electrical supply for the building.
- 3 Lighting required in Sentence (1) shall be designed to be automatically actuated for a period of at least 30 min when the electric lighting in the affected area is interrupted.
- 4 Illumination from lighting required in Sentence (1) shall be provided to average levels of not less than 10 lx at floor or tread level.
- 5 The minimum value of the illumination required by Sentence (4) shall be not less than 1 lx.
- 6 Where incandescent lighting is provided, lighting equal to 1 W/m<sup>2</sup> of floor area shall be considered to meet the requirement in Sentence (4).
- 7 Where self-contained emergency lighting units are used, they shall conform to CSA C22.2 No. 141, "Emergency Lighting Equipment."

# Building Code

Extracts from the National Building Code of Canada 2010

## APPENDIX A EXPLANATORY MATERIAL

### A-3.1.2. Use Classification

The purpose of classification is to determine which requirements apply.

This Code requires classification in accordance with every major occupancy for which the building is used or intended to be used. Where necessary, an application clause has been inserted in this Part to explain how to choose between the alternative requirements which multiple occupancy classification may present.

#### A-3.1.2.1.[1] Major Occupancy Classification.

The following are examples of the major occupancy classifications described in Table 3.1.2.1.:

EXAMPLES		GROUP	DIVISION
Motion picture theatres Opera houses Television studios admitting a viewing audience Theatres, including experimental theatres		A	1
Art galleries Auditoria Bowling alleys Churches and similar places of worship Clubs, nonresidential Community halls Courtrooms Dance halls Exhibition halls (other than classified in Group E) Gymnasias	Lecture halls Libraries Licensed beverage establishments Museums Passenger stations and depots Recreational piers Restaurants Schools and colleges, nonresidential Undertaking premises	A	2
Arenas Indoor swimming pools, with or without spectator seating Rinks		A	3
Amusement park structures (not elsewhere classified) Bleachers Grandstands	Reviewing stands Stadiums	A	4
Jails Penitentiaries Police stations with detention quarters	Prisons Psychiatric hospitals with detention quarters Reformatories with detention quarters	B	1
Care facilities with treatment Convalescent /recovery/rehabilitation centres with treatment Hospices with treatment Hospitals	Infirmaries Nursing homes with treatment Psychiatric hospitals without detention quarters Respite centres with treatment	B	2
Assisted/supportive living facilities Care facilities without treatment Children's custodial homes Convalescent/recovery/rehabilitation centres without treatment	Group homes Hospices without treatment Nursing homes without treatment Reformatories without detention quarters Respite centres without treatment	B	3
Apartments Boarding houses Clubs, residential Colleges, residential Convents Dormitories	Hotels Houses Lodging houses Monasteries Motels Schools, residential	C	

## EXAMPLES

## GROUP

## DIVISION

Banks Barber and hairdressing shops Beauty parlours Dental offices Dry cleaning establishments, self-service, not using flammable or explosive solvents or cleaners Laundries, self-service	Medical offices Offices Police stations without detention quarters Radio stations Small tool and appliance rental and service establishments	D	
Department stores Exhibition halls Markets	Shops Stores Supermarkets	E	
Bulk plants for flammable liquids Bulk storage warehouses for hazardous substances Cereal mills Chemical manufacturing or processing plants Distilleries Dry cleaning plants Feed mills	Flour mills Grain elevators Lacquer factories Mattress factories Paint, varnish and pyroxylin product factories Rubber processing plants Spray painting operations Waste paper processing plants	F	1
Aircraft hangars Box factories Candy plants Cold storage plants Dry cleaning establishments not using flammable or explosive solvents or cleaners Electrical substations Factories Freight depots Helicopter landing areas on roofs Laboratories Laundries, except self-service Mattress factories Planing mills	Printing plants Repair garages Salesrooms Service stations Storage rooms Television studios not admitting a viewing audience Warehouses Wholesale rooms Woodworking factories Workshops	F	2
Creameries Factories Laboratories Light-aircraft hangars (storage only) Power plants Salesrooms	Sample display rooms Storage garages, including open air parking garages Storage rooms Warehouses Workshops	F	3

### A-3.4.5.1.(2)(C) GRAPHICAL SYMBOLS FOR EXIT SIGNS

#### ISO 7010, "Graphical" symbols – Safety colours

and safety signs – Safety signs used in workplaces and public areas," identifies the following internationally recognized symbols for use at required exits



### "EMERGENCY EXIT RIGHT" (E001) SYMBOL FROM ISO 7010



#### Figure A-3.4.5.1.(2)(c)-B

#### 90-degree directional arrow (E005) from ISO 7010

#### A-3.4.5.1.(4) Externally Illuminated Signs

An external lighting source is required to properly charge photoluminescent signs. These types of signs must be lit in conformance with the charging requirements stated in CAN/ULC-S572.

#### A-3.4.6. Application to Means of Egress

The requirements in Subsection 3.4.6. apply to interior and exterior exits, as well as to ramps, stairways and passageways used by the public as access to exit. The treads, risers, landings, handrails and guards for the latter access to exit facilities must thus be provided in conformance with the appropriate requirements for exit facilities.

# Fire Code

Extracts from the National Fire Code of Canada 2010

# Generator Room

Extracts from the Canadian Standards Association 2010

## 2.7. SAFETY TO LIFE

### 2.7.3. EXIT LIGHTING, EXIT SIGNS AND EMERGENCY LIGHTING

#### 2.7.3.1. INSTALLATION AND MAINTENANCE

- 1) Exit lighting, exit signs and emergency lighting shall be provided in buildings in conformance with the NBC. (See Appendix A.)
- 2) Exit lighting and exit signs shall be illuminated during times when the building is occupied.
- 3) Emergency lighting shall be maintained in operating condition, in conformance with Section 6.5.

## 6.5. EMERGENCY POWER SYSTEMS AND UNIT EQUIPMENT FOR EMERGENCY LIGHTING

### 6.5.1.1. INSPECTION, TESTING AND MAINTENANCE

- 1) Except as provided in Articles 6.5.1.2. to 6.5.1.5., emergency power systems shall be inspected, tested and maintained in conformance with CAN/CSA-C282, "Emergency Electrical Power Supply for Buildings."
- 2) An emergency electrical power supply system for emergency equipment for health care facilities shall be inspected, tested and maintained in conformance with CSA Z32, "Electrical Safety and Essential Electrical Systems in Health Care Facilities." (See Appendix A.)

### 6.5.1.2. NOTIFICATION

- 1) When an emergency power system or any part thereof is shut down, the supervisory staff shall be notified in conformance with Section 2.8.

### 6.5.1.3. INSTRUCTIONS

- 1) Where an emergency power system is installed, instructions shall be provided for switching on essential loads and for starting the generator when this is not done automatically.

### 6.5.1.4. RECORDS

- 1) Written records shall be maintained as required in CAN/CSA-C282, "Emergency Electrical Power Supply for Buildings".

### 6.5.1.6. INSPECTION OF UNIT EQUIPMENT

- 1) Self-contained emergency lighting unit equipment shall be inspected at intervals not greater than one month to ensure that
  - a) pilot lights are functioning and not obviously damaged or obstructed,
  - b) the terminal connections are clean, free of corrosion and lubricated when necessary,
  - c) the terminal clamps are clean and tight as per manufacturer's specifications, and
  - d) the battery surface is kept clean and dry.
- 2) Self-contained emergency lighting unit equipment shall be tested
  - a) at intervals not greater than one month to ensure that the emergency lights will function upon failure of the primary power supply, and
  - b) at intervals not greater than 12 months to ensure that the unit will provide emergency lighting for a duration equal to the design criterion under simulated power failure conditions.
- 3) After completion of the test required in Clause (2)(b), the charging conditions for voltage and current and the recovery period shall be tested to ensure that the charging system is functioning in accordance with the manufacturer's specifications.

## SECTION 6.11

### EMERGENCY LIGHTING

#### 6.11.1

The emergency electrical power supply room and the automatic transfer switch room, where separate, shall be equipped with unit equipment for emergency lighting that complies with CSA C22.2 No. 141. Sufficient lamps shall be provided to ensure that a minimum lighting level of 50 lx for 2 h is available at all equipment locations requiring adjustment or service.

Note: This illumination level is significantly greater than that specified in the NBCC, which requires 10 lx for egress route emergency lighting

#### 6.11.2

Emergency lighting units shall be tested in accordance with Table 2 and CSA C22.2 No. 141.

#### 6.11.3

The emergency lighting unit shall include

- (a) automatic self-diagnostic circuitry; and
- (b) a transient voltage surge suppressor on the supply side of power to the unit.

# Limited Warranty

## WARRANTY

- 1.1 **Emergi-Lite**® emergency lighting equipment units (excluding AC and DC Central Systems, lamps, pilot lights and fuses) are fully warranted to be free of defects in material and workmanship under normal use for a period of one (1) year. **Emergi-Lite**® emergency lighting equipment units with the NEXUS® option are fully warranted to be free of defects in material and workmanship under normal use for a period of five (5) years. The full warranty period begins on the date of installation or ninety (90) days from the date of shipment, whichever date is earlier.
- 1.2 DC and AC Central Systems are covered by a separate comprehensive warranty.
- 1.3 LED strips used in **Emergi-Lite**® Exit signs are warranted to be free of defects in material and workmanship under normal use for a period of ten (10) years. The full warranty period begins on the date of installation or ninety (90) days from the date of shipment, whichever date is earlier.
- 1.4 **Emergi-Lite**® unit equipment batteries are warranted to be free of defects in material and workmanship under normal use for a period of one (1) year full and nine (9) years Pro Rata. The full warranty period begins on the date of installation or ninety (90) days from the date of shipment, whichever date is earlier. Batteries have a maximum storage life (shelf life) of 6 months. Batteries must be recharged or placed in service within the 6 months storage life or battery warranty will be void.
- 2.1 Should defect appear in the equipment or batteries listed in the paragraph 1.1, 1.2, 1.3 or 1.4 above within the specified full warranty period, **Emergi-Lite**® will repair or replace equipment without charge (see paragraph 3.4). Such repair or replacement shall be the purchaser's exclusive remedy.
- 2.2 The Pro Rata Warranty period for batteries begins on the date the full warranty ends.
- 2.3 A battery determined to be defective during the Pro Rata Warranty Period shall be repaired or replaced at a cost equal to the net price in effect at the time, reduced by the percentage obtained in multiplying 10% by the number of full years remaining in the total warranty period. Such repair or replacement at this adjusted price shall be the purchaser's exclusive remedy.
- 3.1 All warranties are subject to proper installation and maintenance in accordance with the instructions supplied.
- 3.2 Any material deemed defective must be returned freight prepaid, to a service depot for evaluation (see paragraph 5.1). Any changes in circuitry or components by other than an authorized **Emergi-Lite**® personnel or its service companies will void the warranty.
- 3.3 All warranties are limited to the repair and/or replacement of parts or equipment, which, upon examination at our service depot, are determined to be defective and in our judgment are subject to repair or replacement under warranty. Replacement of lamps, pilot lights, and fuses is not included in the warranty.
- 3.4 If new replacement parts are shipped before defective goods are received for evaluation, the replacement parts will be invoiced at the net price in effect at the time. These charges will be credited if, upon receipt and evaluation of goods, a defect is determined. Only replacement parts will be shipped under these circumstances, if field replacement is possible. **Emergi-Lite**® factory only reserves the right to ship new unit equipment for replacement purposes. Unit returned after installation cannot be restored to 100% saleable condition.
- 4.1 In no event shall **Emergi-Lite**® be liable for back charges of any kind, including without limitation, labor charges for field repair or late penalties.
- 4.2 This warranty does not cover damages caused by abuse, improper maintenance or installation or damage due to installation areas with other than normal temperatures and environmental conditions per application specifications. **Emergi-Lite**® assumes no responsibility for any damages to people, property, apparatus or otherwise resulting from improper installation or maintenance of its emergency lighting unit equipment.
- 4.3 This warranty does not cover damages caused by abuse, fire or act of God.
- 4.4 In no event shall **Emergi-Lite**® be liable for incidental or consequential damages.
- 4.5 The foregoing warranty is in lieu of other warranties, expressed or implied. Except as stated in this warranty, **Emergi-Lite**® shall not be liable for any defects in, or breach of any contract relating to, the quality of performance of **Emergi-Lite**® equipment under any theory of law including, without limitation, contract, negligence, strict liability or misrepresentation.
- 4.6 **Emergi-Lite**® warranty coverage shall not apply to any equipment of another manufacturer used in conjunction with **Emergi-Lite**® equipment.
- 5.1 Defective goods returned to the factory must be shipped prepaid. Any and all collect returned shipments will be refused. Freight charges to return repaired equipment or ship replacement equipment to the purchaser to be paid by **Emergi-Lite**®. Factory will return repaired or replacement goods via same shipping method as received whenever possible and practical.

# PRODUCT INDEX

NAME	SERIES	PG	NAME	SERIES	PG	NAME	SERIES	PG	NAME	SERIES	PG
EDE	EDE	16-17	Premier™ Combo	PRE	56-57	ESLT	06ESLT	108-109	EF18	EF18	145
EX30	EX3	18-19	C8SRPK	C8SRPK1	58	ESLT	12ESLT	108-109	EF18D	EF18D	145
EAE	EAE	20	C8ESPK	C8SRPK2	59	ESLT	24ESLT	108-109	EF18T	EF18T	145
EX3	EX38	21	C8SRPK-P	C8SRPK	60-61	WP36	WP	110	Distinction™	EF150	146
EX3	EX39	21	EN	EN	62	Eclipse™	ECL	111	EFR Distinction™	EFR	147
C8SR3	C8SR38	22	LPEX600	LPEX60	63	JMLC	06JMLC	112-113	EF39	EF39	148-149
C8SR3	C8SR39	22	ENC	ENC	64	JMLC	12JMLC	112-113	EF25	EF25	150
EX3F	EX38F	23	LPEX600-N	LPEX60	65	JMLA	06JMLA	114	EF26	EF26	151
EX3F	EX39F	23	EH	EH	66	JMLA	12JMLA	114	EF26DS	EF26D	151
C8SR35	C8SR36	24	LPEXHZ	LPEXHZ	67	JEM18P	JEM	115	EF26D	EF26DS	151
C8SR35	C8SR36R	24	EHC	EHC	68-69	Premier™	06PRE	116-117	EF11	EF11	152
C8SR35	C8SR37	24	EXHZ	EXHZ	70-71	Premier™	12PRE	116-117	EF11D	EF11D	152
C8ES35 & C8SE35	C8ES	25	EX	EX	72-73	ESL	06ESL	118-119	EF11T	EF11T	152
C8ES35 & C8SE35	C8SE	25	LPEX-XP	LPEXXP	74-75	ESL	12ESL	118-119	EF30	EF30	153
C8E/S35R	C8ES	26	C8SRXP	C8SRXP1	76-77	ESL	24ESL	118-119	EF30D	EF30D	153
PRE	PRED	27	EXP	EXP	78-79	NXM	06NXM	120-121	EF30T	EF30T	153
LPEX100	LPEX	28	EXP	EXP	80-81	NXM	12NXM	120-121	EF45Q	EF45Q	154
LPSR100	LPSR	29	EX160	EX16	82	IPE	IPE	122	EF45DQ	EF45DQ	154
LPEX300	LPEX30	30	SR160	SR16	82	SIPE	SIPE	123	EF41	EF41	154
LPSR300	LPSR30	31	ET	ET	82	ESLPK	06ESL	124-125	EFXPR	EFXPR	155
C8ES300	C8ES30	32	Retrofit Kits	SNAP II	84	ESLPK	12ESL	124-125			
EA	EA	33	Retrofit Kits	SNAP III	85	ESLPK	24ESL	124-125			
LPEX50	LPEX5	34	Retrofit Kits	SNAP I	85	HZM	06HZM	126-127			
C8SR50	C8SR5	35	Retrofit Kits	BULBI/ HB	86	HZM	12HZM	126-127			
LPEX	LPEX	36				ESLNX	06ESL	128-129			
LPEX54	LPEX54	37	Retrofit Kits	BULBII/ HB	86	ESLNX	12ESL	128-129			
C8ES70 & C8SE70	C8	38	Pendant Kit	P1E	87	ESLNX	24ESL	128-129			
ES70B12	ES	39	Pendant Kit	P2E	87	48 & FPS	FPS800	130			
EAC	EAC	40-41	Pendant Kit	P23E	87	48 & FPS	FPS1600	130			
LPEX50-P	LPEX52	42	Pendant Kit	P4E	87	48 & FPS	FPS3200	130			
C8SR50-P	C8SR52	43	DEL Lux-Ray™	LUX	98-99	48 & FPS	FPS	130			
ES	ES	44	Retract-a-Lite™	RTL	100	DEL Lux-Ray™	LUX	138			
EX10	EX10	45	Mini Retract-a-Lite™	MR	101	EF40	EF40M	139			
C8SR10	C8SR10	46	Provider™	CPRO	102	Retract-a-Lite™	12RTL	140			
C8ES10 & C8SE10	C8	47	Distinction™	EFR2	103	Retract-a-Lite™	24RTL	140			
ESC	ESC	48	Distinction™	06ESL	104-105	Mini Retract-a-Lite™	MR	141			
EX10-P	EX10	49	Distinction™	12ESL	104-105	Literay™	EF33	142			
SR	SR12	50-51	Distinction™	24ESL	104-105	EF9/EF9Q/ EF9M	EF9	143			
12ESL-EX	12ESL	52	DEL	06DEL	106-107	EF15	EF15	144			
12ESL-SR	12ESL	53	DEL	12DEL	106-107						
EP	EP	54	DEL	24DEL	106-107						
Premier™ Exit	PRE	55									

The logo for EMERGI-LITE, featuring a stylized blue square icon with a white diagonal line to the left of the text "EMERGI-LITE" in a bold, blue, sans-serif font, followed by a registered trademark symbol (®).

[www.emergi-lite.ca](http://www.emergi-lite.ca)

**Thomas & Betts**  
A Member of the ABB Group

All information and specifications contained in this catalogue are subject to change due to engineer design, errors and omissions.  
Illustrations and diagrams within this catalogue may vary from actual products.  
© 2013 Thomas & Betts Limited. All rights reserved.  
Printed in Canada.  
2013/11/3000 Order No.: ELCAT-ENG