



RL3FTC THREE PHASE SERIES

Fast transfer emergency lighting inverter system 4.8KVA – 50KVA

new product

FEATURES

- 98% efficient at full load
- 2 ms transfer time
- PWM/IGBT technology
- Self-testing/self-diagnostic
- User programmable with password protection
- Standard input circuit breaker
- Internal maintenance bypass (MBB)
- RS232 communication port
- Microprocessor controlled
- 30 min. standard run time
- Generator compatibility
- Available in Y or Δ input configuration
- Custom voltages available
- Automatic event, test and alarm log
- LCD display
- Reduced footprint
- Maintenance-free VRLA batteries
- Forced air cooling during emergency mode only
- cUL Listed to CSA 22.2.141-15. Meets NFPA101



RL3FTC SERIES 30 MINUTE RUN TIME

PARTIAL MODEL NUMBER	POWER RATING (KW) 30 MIN.	VOLTAGE IN-OUT VAC	ELECTRONIC CABINET DIMENSIONS (CM)				BATTERIES		BATTERY CABINET DIMENSIONS (CM)				TOTAL SYSTEM WEIGHT (KG)	TOTAL NO. OF CABINETS	347V XFM CABINET
			W (CM)	H (CM)	D (CM)	WEIGHT (KG)	NO. OF BATTERIES	WEIGHT (KG)	W (CM)	H (CM)	D (CM)	WEIGHT (KG)			
1	4.8	120/208 or 277/480	76	119	64	243	12	198	44	157	64	129	570	2	Top cabinet
		347/600		175		329							656	2	
2	6.0	120/208 or 277/480	76	119	64	243	15	248	44	157	64	129	620	2	Top cabinet
		347/600		175		329							706	2	
3	8.0	120/208 or 277/480	76	119	64	243	20	330	44	157	64	129	702	2	Top cabinet
		347/600		175		329							788	2	
4	10.0	120/208 or 277/480	76	119	64	290	12	390	58	196	64	170	850	2	Top cabinet
		347/600		175		386							946	2	
5	12.5	120/208 or 277/480	76	119	64	290	15	488	58	196	64	170	948	2	Top cabinet
		347/600		175		396							1054	2	
6	16.7	120/208 or 277/480	76	119	64	290	20	650	58	196	64	170	1110	2	Top cabinet
		347/600		175		396							1217	2	
7	24.0	120/208 or 277/480	112	183	79	567	40	1301	122	183	79	295	2163	2	Side cabinet
		347/600	188			702							2297	3	
8	33.0	120/208 or 277/480	112	183	79	567	40	1301	122	183	79	295	2163	2	Side cabinet
		347/600	188			719							2315	3	
9	40.0	120/208 or 277/480	112	183	79	662	60	1951	122	183	79	318	2931	2	Side cabinet
		347/600	188			829							3098	3	
10	50.0	120/208 or 277/480	112	183	79	662	60	1951	122	183	79	318	2931	2	Side cabinet
		347/600	188			829							3098	3	



RL3FTC THREE PHASE SERIES

Fast transfer emergency lighting inverter system 4.8KVA – 50KVA

RL3FTC SERIES 60, 90 AND 120 MINUTE RUN TIME

PARTIAL MODEL NUMBER	POWER RATING (KW)			VOLTAGE IN-OUT VAC	ELECTRONIC CABINET DIMENSIONS (CM) ¹				BATTERIES		BATTERY CABINET DIMENSIONS (CM) ¹				TOTAL SYSTEM WEIGHT (KG)	TOTAL NO. OF CABINETS	347V XFM CABINET
	60 MIN.	90 MIN.	120 MIN.		W (CM)	H (CM)	D (CM)	WEIGHT (KG)	NO. OF BATTERIES	WEIGHT (KG)	W (CM)	H (CM)	D (CM)	WEIGHT (KG)			
1	4.8	4.44	4.08	120/208 or 277/480	76	119	64	243	12	390	76	119	64	95	728	2	Top cabinet
				347/600				329									
2	6.0	5.55	5.10	120/208 or 277/480	76	119	64	243	15	488	76	119	64	95	826	2	Top cabinet
				347/600				329									
3	8.0	7.40	6.80	120/208 or 277/480	76	119	64	243	20	650	76	119	64	105	998	2	Top cabinet
				347/600				329									
4	10.0	9.25	8.50	120/208 or 277/480	76	119	64	290	24	781	76	119	64	105	1176	2	Top cabinet
				347/600				386									
5	12.5	11.6	10.6	120/208 or 277/480	76	119	64	290	30	976	152	119	64	191	1456	3	Top cabinet
				347/600				396									
6	16.7	15.4	14.2	120/208 or 277/480	76	119	64	290	40	1301	152	119	64	210	1801	3	Top cabinet
				347/600				396									
7	24.0	22.2	20.4	120/208 or 277/480	112	183	79	567	60	1951	122	183	79	318	2836	2	Side cabinet
				347/600				702									
8	33.0	30.5	28.1	120/208 or 277/480	112	183	79	567	80	2602	244	183	79	590	3758	3	Side cabinet
				347/600				719									
9	40.0	37.0	34.0	120/208 or 277/480	112	183	79	662	100	3252	244	183	79	590	4504	3	Side cabinet
				347/600				829									
10	50.0	46.3	42.5	120/208 or 277/480	112	183	79	662	120	3903	244	183	79	635	5200	3	Side cabinet
				347/600				829									

¹The cabinet dimensions above include the side cabinet

DIMENSIONS

Dimensions are approximate and subject to change.

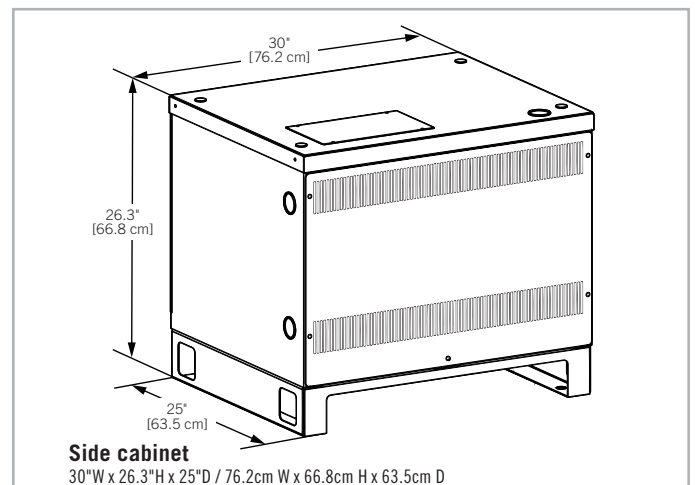
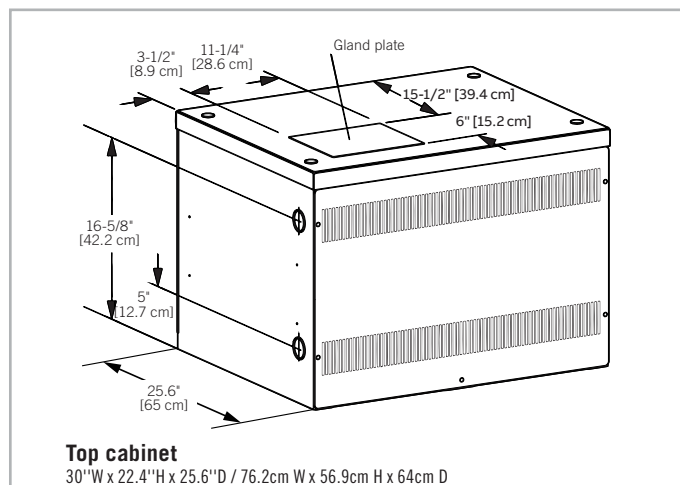



RL3FTC

THREE PHASE SERIES

System specifications

SYSTEM SPECIFICATIONS

GENERAL

DESIGN	Standby PWM inverter type utilizing IGBT technology with 2ms transfer time
CONTROL	Microprocessor controlled, 2 x 20-character display with touch pad controls & functions
METERING	Input and output voltage, battery voltage, battery and output current, output VA, temperature, inverter wattage
COMMUNICATION	RS-232 port (DB9)

ELECTRICAL INPUT

VOLTAGE	120/208, 277/480 or 347/600VAC, 3 phase 4-wire +10% - 15%. Contact factory for all other voltages
INPUT POWER WALK-IN	Limiting inrush current to less than 125%, 10 times for 1 line cycle
INPUT FREQUENCY	60Hz, +/-3%, 50Hz available upon request
PROTECTION	Input circuit breaker
HARMONIC DISTORTION	<10%
POWER FACTOR	0.5 lag/lead

ELECTRICAL OUTPUT

VOLTAGE	120/208, 277/480 or 347/600VAC, 3-phase 4 wire. Contact factory for all other voltages
STATIC VOLTAGE	Load current change +/-4%, battery discharge +/-4%
DYNAMIC VOLTAGE	+/-3% for +/-25% load step change +/-6% load step change, recovery within 3 cycles
HARMONIC DISTORTION	<3% THD for linear load
OUTPUT FREQUENCY	60Hz +/- 0.05Hz during emergency mode
LOAD POWER FACTOR	0.5 lag to 0.5 lead
OVERLOAD CAPABILITY	To 115% continuous rating - 150% for 2.5 seconds, 250% for 3 line cycles
PROTECTION	Optional distribution circuit breaker
CREST FACTOR	2.8

ENVIRONMENTAL CONDITIONS

STORAGE/TRANSPORT	<ul style="list-style-type: none"> -4°F to 158°F (-20°C to 70°C) without batteries max. 3 months at 104° F (40°C) -0°F to 104°F (-18°C to 40°C) with batteries
OPERATING TEMPERATURE	System operates safely from 32°F to 104°F (0°C to 40°C) but optimum operation is between 68°F and 86°F (20°C to 30°C). Battery performance can be affected by temperature
ALTITUDE	<10,000 feet (above sea level) without de-rating
RELATIVE HUMIDITY	0 to 95% non-condensing
AUDIBLE NOISE	50 dBA at 1m from surface in emergency mode

SINGLE LINE DIAGRAM

Normally on output circuit

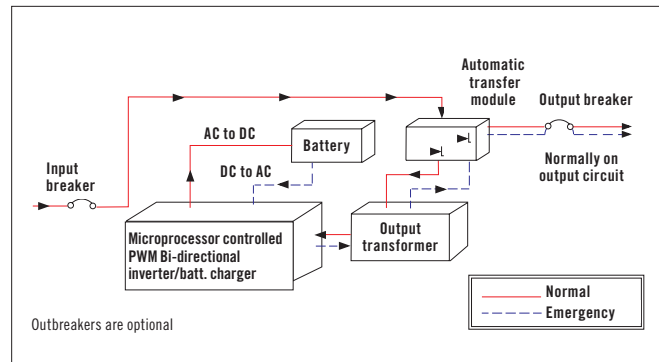

CABINETS

Modular design, freestanding NEMA type 1 steel cabinets powder coated for corrosion and scratch resistance. Front access design through hinged lockable doors requires only 39" front clearance and 12" top clearance. Cabinets are stackable up to 16.7kVA, if required to further reduce the footprint. Top and left side conduit entry with knockouts up to 16.7kVA. Left side only for 24kVA and up.

INVERTER

Using IGBT/PWM technology the inverter converts the DC voltage supplied by the batteries to AC voltage of a precise stabilized amplitude and frequency, suitable for most sophisticated electrical equipment. True sinusoidal output waveform with very low distortion (less than 3% for linear loads). Overload capability of up to 150% for 2.5 seconds.

CHARGER

Fully automatic, temperature compensated, microprocessor controlled charger recharges fully discharged batteries in maximum 24 hours at nominal AC input voltage. AC input current limiting and over-voltage protection included.

BATTERY

System is provided standard with 10 year, maintenance-free, sealed valve regulated, front terminals lead-calcium batteries. 20 year sealed lead-calcium battery also available. 30 min. standard discharge time at full load under normal operating temperature. Low voltage disconnect protection included. No special ventilation required.

SELF-DIAGNOSTIC

Automatic self-tests consist of a 5 minute monthly and full run time annual function. The front-mounted control panel includes 5 LED indicators, a 4 line 20 character LCD display, a keypad to control and monitor the internal operation of the system. This allows the operator to easily "watch" system functions as they occur and check on virtually any aspect of the system's operation. Standard RS232 diagnostic interface.

ALARMS

High/low battery charger voltage, high/low AC input voltage, near low battery, low battery, load reduction fault, output overload, high ambient temperature, inverter fault, output fault, optional output circuit breaker trip.

OPTIONAL FEATURES

Output circuit breakers, output trip alarms, 20 year sealed batteries, 12 hour fast recharge, internal/external maintenance bypass switch (BBM), battery cabinet fans, remote status panel, status monitoring contacts, load control interface for dimmer and switch bypass in emergency, remote summary alarm panel, summary alarm dry form C contact, inverter on dry contacts, normally-off output, bypass relays, seismic mounting, circuit breaker locks, battery temperature monitor, drip top (NEMA 2), output transfer delay, time delay, zone monitoring, BACnet IP or MS/TP, remote meter panel, MODBUS TCP/IP or RTU, serial to ethernet adapter.

FACTORY START-UP

Includes one additional year of warranty. See warranty conditions.

WARRANTY (Full limited warranty conditions available upon request)

Limited manufacturer warranty is one year, parts and labor, for system electronics or two year with factory start-up program. Battery warranty is one year full plus 9 years pro-rata for a total of 10 years, under normal operating conditions. System must be put in service within 6 months from ship date in order to validate warranty.



RL3FTC THREE PHASE SERIES

System specifications
and ordering information

ORDERING INFORMATION

INPUT/OUTPUT VOLTAGE ¹	BATTERY TYPE	W/KVA RATING	SYSTEM TYPE	RUN TIME	OUTPUT BREAKER CONFIG.	OUTPUT BREAKER VOLTAGE	OUTPUT BREAKER AMP. ²
1= 120/208-120/208 2= 277/480-277/480 3= 120/208-277/480 4= 277/480-120/208 5= 347/600-347/600 6= 120/208-347/600 7= 277/480-347/600 8= 347/600-120/208 9= 347/600-277/480	SC= Standard 6= Long-life 20 year sealed battery	4800= 4.8 6000= 6.0 8000= 8.0 10000= 10 12500= 12.5 16700= 16.7 24000= 24.0 33000= 33.0 40000= 40.0 50000= 50.0	RL3FTC	R30= 30 minutes R60= 60 minutes R90= 90 minutes R120= 120 minutes	B= Normally-on N= Normally-off	A= 120, 1 pole B= 208, 2 pole D= 277, 1 pole E= 120/208, 3 pole F= 277/480, 3 pole G= 480, 2 pole H= 347, 1 pole I= 347/600, 3 pole	10= 10 16= 16 20= 20 25= 25 32= 32 40= 40 50= 50 63= 63
¹ Special voltages may change the size, weight or number of cabinets							² Higher amp ratings available (contact factory)
OUTPUT BREAKER QTY.	OPTIONS			MONITORING ⁴		WARRANTY (1 YR. STD.)	ACCESSORIES
01-42= Choose the number of output breakers between 01 and 42 ³	A= Remote summary alarm panel (requires S option) BCF= Battery cabinet fans BTM= Battery temperature monitor BL= Breaker locks C= Status monitoring contacts DT= Drip top (NEMA 2) F= Fast charge I= Inverter on dry form C contact L= Load control interface (dimmer/switch bypass) M(BBM)= Internal maintenance bypass O= Output transfer delay P= Remote status panel (requires C option) S= Summary fault form C contacts T= Output trip alarm (supervised) V= Time delay 15 minutes Z= Seismic bracing/mounting ZM= Zone monitoring			BAC= Bacnet communication (MSTP) MOD= Modbus RTU BIP= BACnet IP MIP= Modbus TCP/IP R= Remote meter panel SEA= Serial to ethernet adapter		2YW= Startup and same day training 2YT= Startup, same day training and full run test ⁵ 5YP= 5 year preventative maintenance plan (startup included) 5YW= 5 year extended electronics warranty TR= Training if required on day other than startup	Blank= No accessories EMBP= External maintenance bypass switch ⁶ SPARES= Spare fuses and circuit boards SPAREF= Spare fuse kit
³ Maximum output breakers quantity available: 4.8k to 16.7k systems 12 unsupervised (1 pole) or 8 supervised (1 pole). With the addition of a top enclosure, an additional 30 unsupervised (1 pole) or 20 supervised (1 pole). 24k to 50k systems 36 unsupervised (1 pole), or 30 supervised (1 pole). Combinations of 1, 2 and/or 3 pole breakers available (contact factory)				⁴ May only choose one monitoring option		⁵ Load must be connected, additional day on-site required	⁶ Cannot be purchased with internal output breaker option

EXAMPLE: 1SC4800RL3FTCR60BA1005SBAC