



RLFT SINGLE PHASE SERIES

Fast transfer emergency lighting inverter system 1.5KVA –16.7KVA

new product

FEATURES

- 98% efficient at full load
- 2ms transfer time
- PWM/IGBT technology
- Self-testing/Self-diagnostic
- User programmable with password protection
- Standard input circuit breaker
- RS232 communication port
- Micro-processor controlled
- 30 min. standard run time
- Generator compatibility
- Custom and mixed voltages available
- Automatic event, test and alarm log
- Space saving single cabinet design
- Maintenance free standard batteries
- Forced air cooling during emergency mode only
- cUL Listed to CSA 22.2.141-15. Meets NFPA101



RLFT SERIES 30 MINUTE RUN TIME

PARTIAL MODEL NUMBER	POWER RATING (KW) 30 MIN.	VOLTAGE IN-OUT VAC	CABINET DIMENSIONS (CM)				BATTERIES		TOTAL SYSTEM WEIGHT (KG)	TOTAL NO. OF CABINETS	347V XFM CABINET
			W (CM)	H (CM)	D (CM)	WEIGHT (KG)	NO. OF BATTERIES	WEIGHT (KG)			
1	1.50	120 or 277	76	119	64	98	4	66	164	1	Top cabinet
		347		175		154			220		
2	2.25	120 or 277	76	119	64	104	6	99	203	1	Top cabinet
		347		175		161			260		
3	3.00	120 or 277	76	119	64	107	8	132	239	1	Top cabinet
		347		175		166			298		
4	3.75	120 or 277	76	119	64	109	10	165	274	1	Top cabinet
		347		175		171			336		
5	5.00	120 or 277	76	119	64	127	12	198	325	1	Top cabinet
		347		175		193			391		
6	6.00	120 or 277	122	193	64	274	15	248	522	1	Side cabinet
		347				198			356		
7	8.00	120 or 277	122	193	64	290	20	330	621	1	Side cabinet
		347				198			377		
8	10.0	120 or 277	122	193	64	356	12	390	746	1	Side cabinet
		347				198			449		
9	12.5	120 or 277	122	193	64	365	15	488	853	1	Side cabinet
		347				198			465		
10	16.7	120 or 277	122	193	64	401	20	650	1052	1	Side cabinet
		347				198			508		



RLFT SINGLE PHASE SERIES

Fast transfer emergency lighting inverter system 1.5KVA –16.7KVA

RLFT SERIES 60, 90 AND 120 MINUTE RUN TIME

PARTIAL MODEL NUMBER	POWER RATING (KW)			VOLTAGE IN-OUT VAC	CABINET DIMENSIONS (CM) ¹				BATTERIES		TOTAL SYSTEM WEIGHT (KG)	TOTAL NO. OF CABINETS	347V XFM CABINET
	60 MIN.	90 MIN.	120 MIN.		W (CM)	H (CM)	D (CM)	WEIGHT (KG)	NO. OF BATTERIES	WEIGHT (KG)			
1	1.50	1.39	1.28	120 or 277	76	119	64	98	4	130	228	1	Top cabinet
				347		175		154			284		
2	2.25	2.08	1.91	120 or 277	76	119	64	104	6	195	299	1	Top cabinet
				347		175		161			356		
3	3.00	2.78	2.55	120 or 277	76	119	64	107	8	260	367	1	Top cabinet
				347		175		166			426		
4	3.75	3.47	3.19	120 or 277	76	119	64	109	10	325	434	1	Top cabinet
				347		175		171			496		
5	5.00	4.63	4.25	120 or 277	76	119	64	127	12	390	517	1	Top cabinet
				347		175		193			583		
6	6.00	5.55	5.10	120 or 277	122	193	64	274	15	488	762	1	Side cabinet
				347	198			356			843		
7	8.00	7.40	6.80	120 or 277	122	193	64	290	20	650	941	1	Side cabinet
				347	198			377			1028		
8	10.0	9.25	8.50	120 or 277	122	193	64	356	24	781	1137	1	Side cabinet
				347	198			449			1230		
9	12.5	11.6	10.6	120 or 277	122	193	64	365	30	976	1341	1	Side cabinet
				347	198			465			1441		
10	16.7	15.4	14.2	120 or 277	122	193	64	401	40	1301	1702	1	Side cabinet
				347	198			508			1809		

DIMENSIONS

Dimensions are approximate and subject to change.

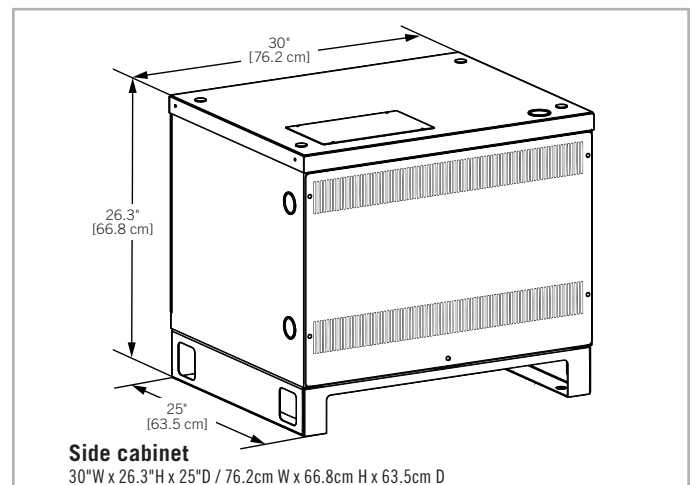
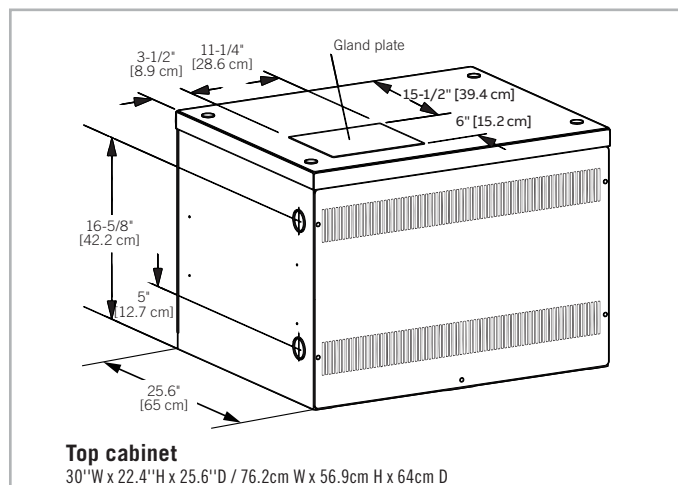



RLFT

SINGLE PHASE SERIES

System specifications

SYSTEM SPECIFICATIONS

GENERAL

DESIGN	Standby PWM inverter type utilizing IGBT technology with 2ms transfer time
CONTROL	Microprocessor controlled, 4 x 20-character OLED display with touch pad controls & functions. Continuous scrolling display of system status and faults, with alarm feature
METERING	Input and output voltage, battery voltage, battery and output current, output VA, temperature, inverter wattage
COMMUNICATION	RS-232 port (DB9)

ELECTRICAL INPUT

VOLTAGE	120, 208, 240, 277 or 347VAC 1-phase 2-wire +10% - 20%. Contact factory for all other voltages
INPUT POWER WALK-IN	Limiting inrush current to less than 125%, 10 times for 1 line cycle
INPUT FREQUENCY	60Hz, +/-3%
PROTECTION	Input circuit breaker
HARMONIC DISTORTION	<10%
POWER FACTOR	0.5 lag/lead

ELECTRICAL OUTPUT

VOLTAGE	120, 208, 240, 277 or 347VAC, 1-phase 2-wire. Contact factory for all other voltages
STATIC VOLTAGE	Load current change +/-4%, battery discharge +/-12.5%
DYNAMIC VOLTAGE	+/- 2% for a +/- 25% load step change +/- 3% for a 50% load step change, recovery within 10 cycles
HARMONIC DISTORTION	<3% THD for linear load
OUTPUT FREQUENCY	60Hz +/- 0.05Hz during emergency mode
LOAD POWER FACTOR	0.5 lag to 0.5 lead
OVERLOAD CAPABILITY	100% for continuous rating, 115% for 10 minutes, 150% for 16 line cycles
PROTECTION	Optional distribution circuit breaker
CREST FACTOR	2.8

ENVIRONMENTAL CONDITIONS

STORAGE/TRANSPORT	<ul style="list-style-type: none"> -4°F to 158°F (-20°C to 70°C) without batteries max. 3 months at 104° F (40° C) -0°F to 104°F (-18°C to 40°C) with batteries
OPERATING TEMPERATURE	System operates safely from 32°F to 104°F (0°C to 40°C) but optimum operation is between 68°F and 86°F (20°C to 30°C). Battery performance can be affected by temperature
ALTITUDE	<10,000 feet (above sea level) without de-rating
RELATIVE HUMIDITY	0 to 95% non-condensing
AUDIBLE NOISE	50 dBA at 1m from surface in emergency mode

SINGLE LINE DIAGRAM

Normally on output circuit

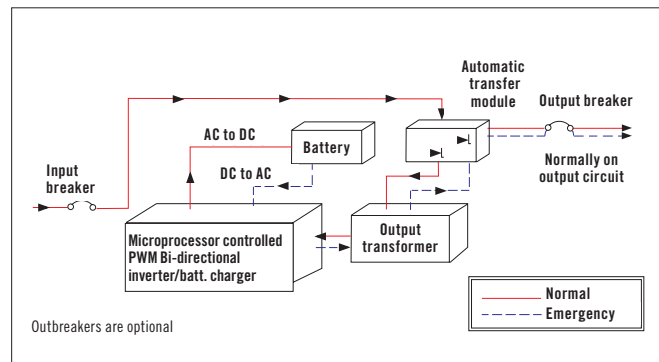

CABINETS

Modular design, freestanding NEMA type 1 steel cabinets powder coated for corrosion and scratch resistance. Front access design through hinged lockable doors requires only 39" front clearance and 12" top clearance. Cabinets are stackable up to 16.7kVA, if required to further reduce the footprint. Top and left side conduit entry with knockouts up to 16.7kVA.

INVERTER

Using IGBT/PWM technology the inverter converts the DC voltage supplied by the batteries to AC voltage of a precise stabilized amplitude and frequency, suitable for most sophisticated electrical equipment. True sinusoidal output waveform with very low distortion (less than 3% for linear loads). Overload capability of up to 150% for 16 line cycles.

CHARGER

Fully automatic, temperature compensated, microprocessor controlled charger recharges fully discharged batteries in maximum 24 hours at nominal AC input voltage. AC input current limiting and over-voltage protection included.

BATTERY

System is provided standard with 10 year, maintenance-free, sealed valve regulated, front terminals lead-calcium batteries. 30 min. standard discharge time at full load under normal operating temperature. Low voltage disconnect protection included. No special ventilation required.

SELF-DIAGNOSTIC

Automatic self-tests consist of a 5 minute monthly and full run time annual function. The front-mounted control panel includes, a 4 line 20 character OLED display, a keypad to control and monitor the internal operation of the system. This allows the operator to easily "watch" system functions as they occur and check on virtually any aspect of the system's operation. Standard RS232 diagnostic interface.

ALARMS

High/low battery charger voltage, charger fault high/low AC input voltage, near low battery voltage, load reduction fault, output overload shutdown, system test failure, high ambient temperature, inverter fault, output fault, optional output circuit breaker trip.

OPTIONAL FEATURES

Output circuit breakers, output trip alarms, 12 hour fast recharge, internal/external maintenance bypass switch (BBM), remote status panel, status monitoring contacts, load control interface for dimmer and switch bypass in emergency, remote summary alarm panel, summary alarm dry form status monitoring contacts, remote status panel, inverter on dry contacts, normally-off output, bypass relays, seismic mounting, circuit breaker locks, battery temperature monitor, drip top (NEMA 2), time delay, zone monitoring, BACnet IP or MS/TP, remote meter panel, MODBUS TCP/IP or RTU, serial to ethernet adapter.

FACTORY START-UP

Includes one additional year of warranty. See warranty conditions.

WARRANTY (Full limited warranty conditions available upon request)

Limited manufacturer warranty is one year, parts and labor, for system electronics or two year with factory start-up program. Battery warranty is one year full plus 9 years pro-rata for a total of 10 years, under normal operating conditions. System must be put in service within 6 months from ship date in order to validate warranty.



RLFT SINGLE PHASE SERIES

System specifications
and ordering information

ORDERING INFORMATION

INPUT/OUTPUT VOLTAGE	SERIES	NOMINAL CAPACITY	BATTERY TYPE	RUN TIME	OUTPUT BREAKER CONFIG.	OUTPUT BREAKER VOLTAGE	OUTPUT BREAKER AMPERAGE	OUTPUT BREAKER QTY.				
1= 120-120 2= 120-120/277 3= 208-120 ¹ 4= 240-120/240 5= 277-120 6= 277-277 7= 277-277/120 8= 208-120/240 ¹ 9= 347-347 A= 208-120/208 ¹	RLFT	1= 1500VA 2= 2250VA 3= 3000VA 4= 3750VA 5= 5000VA 6= 6000VA 7= 8000VA 8= 10.0KVA 9= 12.5KVA 10= 16.7KVA	SG= Standard	R30= 30 minutes R60= 60 minutes R90= 90 minutes R120= 120 minutes	B= Normally-on N= Normally-off ²	A= 120 B= 208 C= 240 D= 277 Z= 347	10= 10 Amp 16= 16 Amp 20= 20 Amps 25= 25 Amps 32= 32 Amps 40= 40 Amps 50= 50 Amps 63= 63 Amps	01-24= Choose the number of output breakers between 01 and 24 ³				
¹ Enclosure height will increase on 1.5 to 5kVA units					² Normally off loads cannot exceed 20% of total KVA rating with any combination of HID loads							
OPTIONS					MONITORING	WARRANTY (1 YR. STD.)		ACCESSORIES				
A= Remote summary alarm panel BL= Circuit breaker locks BTM= Battery temperature monitor C= Status monitoring contacts D= Drip top (NEMA 2) F= Battery charger upgrade (12 hours recharge) I= Inverter on dry form C contact L= Load control relay (dimmer/switch bypass) M(BBM)= Internal maintenance bypass P= Remote status panel (status alarms, requires C option)					R= Remote meter panel S= Summary fault form C contacts T= Output trip (supervised) alarm V= Time delay 15 minutes (15 minute retransfer time delay of normally off circuit after return of utility) Z= Seismic mounting (Anchorage based on calculations. For systems requiring OSHPD/Withstand testing, please contact the factory) ZM= Zone monitoring (quantity must be specified)		BAC= Bacnet communication (MSTP) MOD= Modbus RTU BIP= BACnet IP MIP= Modbus TCP/IP SEA= Serial to ethernet adapter		2YW= Startup and same day training 2YT= Startup, same day training and full run test ⁴ 5YP= 5 year preventative maintenance plan (startup included) 5YW= 5 year extended electronics warranty TR= Training if required on day other than startup ⁴ Load must be connected, additional day on-site required		Blank= No accessories EMBP= External maintenance bypass switch ⁵ SPARES= Spare fuses and circuit boards SPAREF= Spare fuse kit ⁵ Cannot be purchased with internal output breaker option	

EXAMPLE: 2RLFT2SG30BA1603BLBAC

³Maximum output breakers available: 12 unsupervised (1-pole), 8 supervised (1-pole) for 1.5KVA-5KVA; 24 unsupervised (1-pole), 18 supervised (1-pole) for 6KVA-16.7KVA; Breakers provided are 20 Amps unless specified otherwise. A 2-pole breaker occupies 2 positions. Additional output breakers available on 1.5KVA units with optional top mount enclosure. Contact factory for details.