



new product



FEATURES

- 98% efficient at full load
- 2ms transfer time
- PWM/IGBT technology
- Self-testing/self-diagnostic
- User programmable with password protection
- Standard input circuit breaker
- Standard output circuit breaker
- Micro-processor controlled
- Floor or wall mountable
- 30 min. standard run time
- Compatible with all lighting loads LED and HID
- Automatic event, test and alarm log
- Small footprint
- Maintenance-free standard batteries
- Forced air cooling during emergency mode only
- cUL Listed to CSA 22.2.141-15. Meets NFPA101

**RLFTM
SINGLE PHASE SERIES**

Fast transfer emergency lighting inverter system x 1000VA – 2800VA

RLFTM SERIES 30 MINUTE RUN TIME

PARTIAL MODEL NUMBER	POWER RATING (KW) 30 MIN.	VOLTAGE IN-OUT VAC	CABINET DIMENSIONS (CM)				BATTERIES		TOTAL SYSTEM WEIGHT (KG)	TOTAL NO. OF CABINETS
			W (CM)	H (CM)	D (CM)	WEIGHT (KG)	NO. OF BATTERIES	WEIGHT (KG)		
1	1.00	120 or 277	62	70	27	55	4	42	97	1
		347		110		90		132	1	
2	1.60	120 or 277	62	110	27	75	6	63	138	1
		347		140		108		171	1	
3	2.20	120 or 277	62	110	27	78	8	84	162	1
		347		140		108		192	1	
4	2.80	120 or 277	62	140	27	92	10	105	197	1
		347		180		127		233	1	

RLFTM SERIES 60, 90 AND 120 MINUTE RUN TIME

PARTIAL MODEL NUMBER	POWER RATING (KW)			VOLTAGE IN-OUT VAC	CABINET DIMENSIONS (CM)				BATTERIES		TOTAL SYSTEM WEIGHT (KG)	TOTAL NO. OF CABINETS
	60 MIN.	90 MIN.	120 MIN.		W (CM)	H (CM)	D (CM)	WEIGHT (KG)	NO. OF BATTERIES	WEIGHT (KG)		
1	1.00	0.90	0.80	120 or 277	62	70	27	55	4	66	121	1
				347		110		90		156	1	
2	1.60	1.44	1.28	120 or 277	62	110	27	75	6	99	174	1
				347		140		108		207	1	
3	2.20	1.98	1.76	120 or 277	62	110	27	78	8	132	210	1
				347		140		108		240	1	
4	2.80	2.52	2.24	120 or 277	62	140	27	92	10	165	257	1
				347		180		127		293	1	

SYSTEM SPECIFICATIONS

GENERAL

DESIGN	PWM inverter type utilizing IGBT technology with 2ms transfer time
CONTROL	Microprocessor controlled, 4 x 20-character display with touch pad controls & functions. Continuous scrolling display of system status and faults, with alarm feature
METERING	Input and output voltage, battery voltage, battery and system output current, output VA, temperature, inverter wattage
COMMUNICATION	Optional RS-232 port (DB9)

ELECTRICAL INPUT

VOLTAGE	120, 208, 240, 277 or 347VAC
INPUT POWER WALK-IN	Limiting inrush current to less than 125%, 10 times 1 line cycle for incandescent loads
INPUT FREQUENCY	60Hz, +/-3Hz
PROTECTION	Standard input circuit breaker
HARMONIC DISTORTION	<10%
POWER FACTOR	0.5 lag/lead

ELECTRICAL OUTPUT

VOLTAGE	120, 208, 240, 277, or 347VAC, 1-phase 2-wire, +10%/ -10%. Contact factory for all other voltages
STATIC VOLTAGE	Load current change +/-2%, battery discharge +/-12.5%
DYNAMIC VOLTAGE	+/-2% @ 25% load step change and +/-3% @50% load step change Recovery within 3 cycles
HARMONIC DISTORTION	<3% THD for linear load
OUTPUT FREQUENCY	60Hz +/- 0.05Hz during emergency mode
LOAD POWER FACTOR	0.5 lag to 0.5 lead
OVERLOAD CAPABILITY	100% for continuous rating, 115% for 10 minutes, 150% for 16 line cycles
PROTECTION	Optional distribution circuit breaker
CREST FACTOR	3.8

ENVIRONMENTAL CONDITIONS

STORAGE/TRANSPORT	<ul style="list-style-type: none"> -4°F to 158°F (-20°C to 70°C) without batteries -0°F to 104°F (-18°C to 40°C) with batteries max. 3 months at 104° F (40° C)
OPERATING TEMPERATURE	System operates safely from 32°F to 104°F (0°C to 40°C) UL924 listed to provided 30, 60, 90 and 120 mins of battery back up between 68° F and 86°F (20°C to30°C). Battery performance can be affected by temperature
ALTITUDE	<10,000 feet (above sea level) without de-rating
RELATIVE HUMIDITY	0 to 95% non-condensing
AUDIBLE NOISE	45 dBA at 1m from surface in emergency mode

SINGLE LINE DIAGRAM

Normally on output circuit

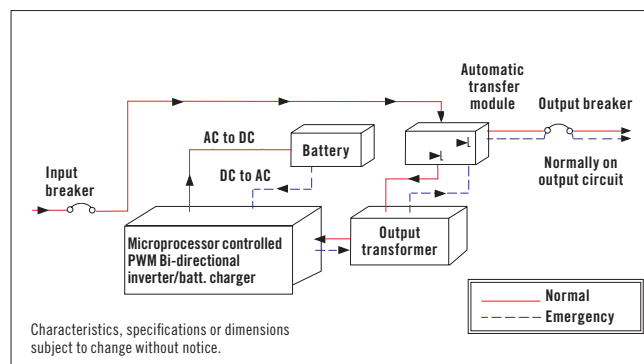

RLFTM

SINGLE PHASE SERIES

System specifications



RLFTM SINGLE PHASE SERIES

System specifications
and ordering information

CABINETS

Single freestanding or wall mount NEMA Type 1 steel cabinets powder coated for corrosion and scratch resistance. Front access design. Top and left side conduit entry with knockouts.

INVERTER

Using IGBT/PWM technology the inverter converts the DC voltage supplied by the batteries to AC voltage of a precise stabilized amplitude and frequency, suitable for most sophisticated electrical equipment. True sinusoidal output waveform with very low distortion (less than 3% for linear loads). Overload capability of up to 150% for 16 line cycles.

CHARGER

Fully automatic, temperature compensated, microprocessor controlled charger recharges fully discharged batteries in maximum 24 hours at nominal AC input voltage. AC input current limiting and over-voltage protection included.

BATTERY

System is provided with 10 year, maintenance free, sealed valve regulated lead calcium batteries. 30 min. standard discharge time at full load under normal operating temperature. Low voltage disconnect protection included. No special ventilation required.

SELF-DIAGNOSTIC

Automatic self-test consists of a 5-minute monthly and full run time annual function. The front-mounted control panel includes a 4-line 20-character OLED display, and a keypad to control and monitor the internal the system. operation of the system. This allows the operator to easily “watch” system functions as they occur and check on virtually any aspect of the system’s operation. Self-diagnostic function monitors, controls, generates alarms and memorizes events.

ALARMS

High battery charger voltage, high/low AC input voltage, near low battery voltage, low battery voltage, load reduction fault, output overload, high ambient temperature, inverter fault, output fault, system test failure, optional output circuit breaker trip, charger fault, output overload shutdown.

OPTIONAL FEATURES

Normally off output, output circuit breakers, output trip alarm, RS232 communication port, remote summary alarm panel, summary alarm dry form C contacts, status monitoring dry form C contacts, remote status panel, inverter on dry contacts, time delay, load control interface for dimmer and switch bypass in emergency, bypass relays, wall mount bracket, circuit breaker lock, drip top (NEMA 2), internal/external maintenance bypass switch, output transfer delay, serial to ethernet adapter, battery strapping, zone monitoring, floor mount bracket, seismic mounting, BACnet IP or MS/TP, Modbus TCP/IP or RTU.

FACTORY START-UP

Includes one additional year of warranty. See warranty conditions.

WARRANTY (Full limited warranty conditions available upon request)

Limited manufacturer warranty is one year, parts and labor, for system electronics or two year with factory start-up program. Battery warranty is one year full plus 9 years pro-rata for a total of 10 years, under normal operating conditions. System must be put in service within 6 months from ship date in order to validate warranty.

ORDERING INFORMATION

INPUT/OUTPUT VOLTAGE	SERIES	NOMINAL CAPACITY	BATTERY TYPE	EMERGENCY RUN TIME	OUTPUT BREAKER CONFIG.	OUTPUT BREAKER VOLTAGE	OUTPUT BREAKER AMPERAGE	OUTPUT BREAKER QTY.
1= 120-120 2= 120-120/277 ¹ 3= 208-120 ¹ 4= 240-120/240 ¹ 5= 277-120 ¹ 6= 277-277 7= 277-277/120 ¹ 8= 208-120/240 ¹ 9= 208-120/208 ¹ 10= 347-347 ¹ ¹ Enclosure height will increase. Contact factory.	RLFTM	1= 1000VA 2= 1600VA 3= 2200VA 4= 2800VA	S= Standard	R30= 30 minutes R60= 60 minutes R90= 90 minutes R120= 120 minutes	B= Normally-on N= Normally-off ²	A= 120 B= 208 C= 240 D= 277 Z= 347	10= 10 A 16= 16 A 20= 20 A 25= 25 A 32= 32 A	01-10= Choose the number of output breakers between 01 and 10 ³
OPTIONS			MONITORING		MOUNTING	WARRANTY (1 YR. STD.)		ACCESSORIES
A= Remote summary alarm panel BL= Circuit breaker lock(s) C= Status monitoring dry form C contacts alarm panel D= Drip top (NEMA 2) I= Inverter on dry form C contact L= Load control relay (contact factory for load control applications) M= Maintenance bypass (MBB) M(BBM)= Internal maintenance bypass O= Output transfer delay (factory set at 3 seconds adjustable 0 to 7.5 seconds) P= Remote status panel (requires “C” option – status monitoring dry form C contacts alarm panel) S= Summary fault form C contacts T= Output trip (supervised) alarm ² V= Time delay 15 minutes (15 minute retransfer time delay of normally off circuit after return of utility) Y= Battery strapping ZM= Zone monitoring (quantity must be specified)			BAC= Bacnet communication (MSTP) MOD= Modbus RTU BIP= BACnet IP MIP= Modbus TCP/IP SEA= Serial to ethernet adapter		Blank= Standard wall F= Floor mount bracket (adds 4” to total system height) W= Wall mount brackets Z= Seismic/raised floor (adds 4” to total system height)	2YW= Startup and same day training 2YT= Startup, same day training and full run test ⁴ 5YP= 5 year preventative maintenance plan (startup included) 5YW= 5 year extended electronics warranty TR= Training if required on day other than startup ⁴ Load must be connected, additional day on-site required		Blank= No accessories EMBP= External maintenance bypass switch ⁵ SPARES= Spare fuses and circuit boards SPAREF= Spare fuse kit ⁵ Cannot be purchased with internal output breaker option

EXAMPLE: 1RLFTM1SR30BA1602BLBAC

³Unless output circuit breakers are specified, a single output breaker will be supplied with each unit and the current rating will vary based on the output power and voltage rating of the unit. Maximum specified output breakers available: 10 unsupervised (1-pole), 6 supervised (1-pole). A 2-pole breaker occupies 2 positions.